

PARTS LIST

MARINE DIESEL ENGINE

7 A One

PUBLICATION NO.

PRELIMINARY



**WESTERBEKE CORPORATION
180 JOHN HANCOCK ROAD
TAUNTON, MA 02780-7319 U.S.A.
WWW.WESTERBEKE.COM**

IMPORTANT

Product Software Disclaimer

Product software of all kinds, such as brochures, drawing, technical data, operator's and workshop manuals, parts lists and parts price lists, and other information, instructions and specifications provided from sources other than Westerbeke, is not within Westerbeke's control and; accordingly, is provided to Westerbeke customers only as a courtesy and service. Westerbeke cannot be responsible for the content of such software, makes no warranties or representations with respect thereto, including the accuracy, timeliness or completeness thereof, and will in no event be liable for any type of damages or injury incurred in connection with, or arising out of, the furnishing or use of such software.

For example, components and subassemblies incorporated in Westerbeke's products and supplied by others (such as engine blocks, fuel systems and components, transmissions, electrical components, pumps and other products) are generally supported by their manufacturers with their own software, and Westerbeke must depend on such software for the design of Westerbeke's own product software. Such software may be outdated and no longer accurate. Routine changes made by Westerbeke's suppliers, of which Westerbeke rarely has notice in advance, are frequently not reflected in the supplier's software until after such changes take place.

Westerbeke customers should also keep in mind the time span between printings of Westerbeke product software and the unavoidable existence of earlier, non-current, Westerbeke software editions in the field. Additionally, most Westerbeke products include customer-requested special features that frequently do not include complete documentation.

In summation, product software provided with Westerbeke products, whether from Westerbeke or other suppliers, must not and cannot be relied upon exclusively as the definitive authority on the respective product. It not only makes good sense but is imperative that appropriate representatives of Westerbeke or the supplier in question be consulted to determine the accuracy and currency of the product software being consulted by the customer.

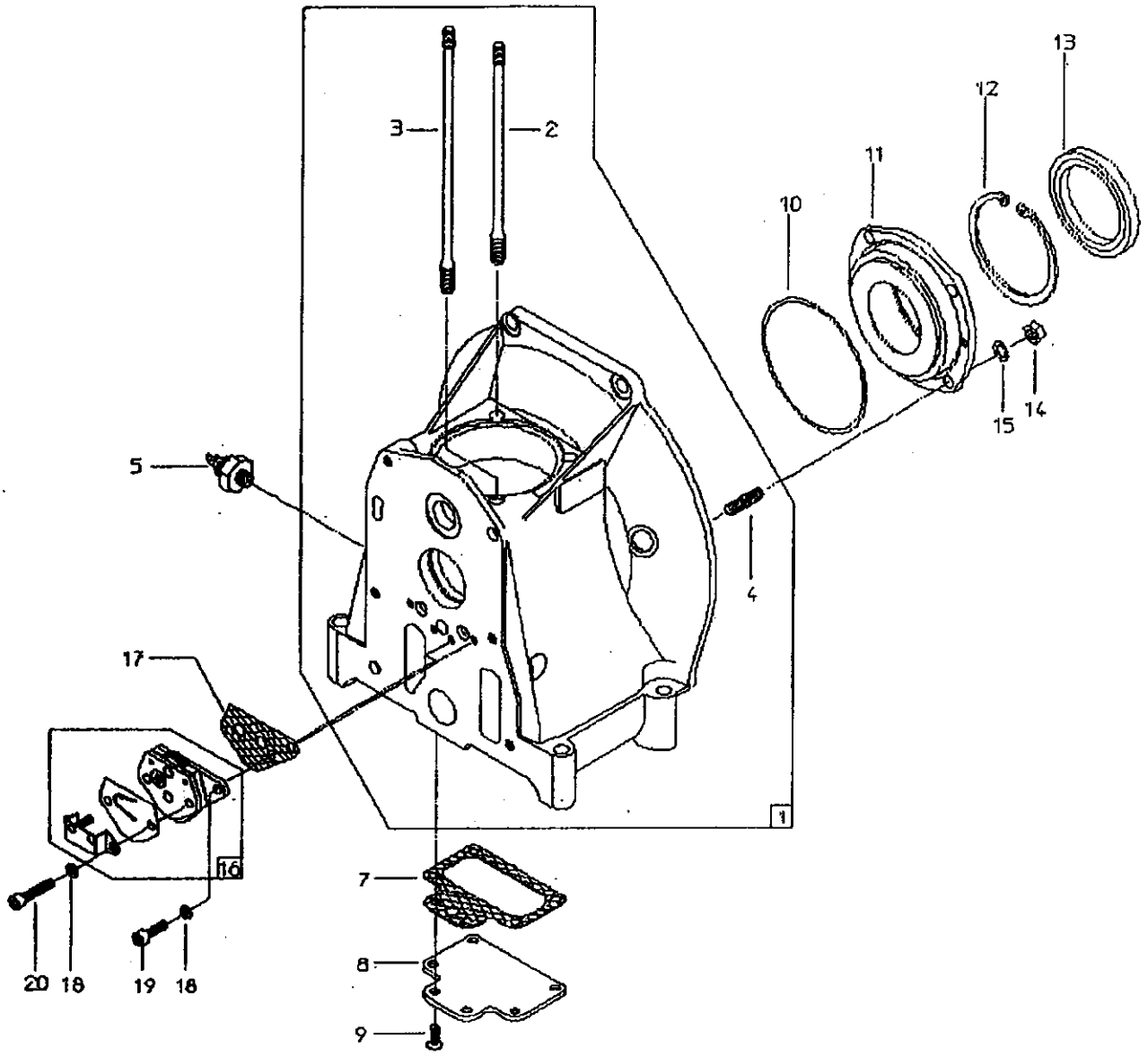

Crankcase

Pos.	Pres.	Designation	
1	1	CRANKCASE ASSY	48607
2	2	STUD-CYL MTG	45714
3	2	STUD-CYL MTG	45715
4	4	STUD	45716
5	1	OIL PRESSURE SWITCH 1-POL	45611
7	1	GASKET-CRANKCASE	45836
7	1	GASKET	
8	1	COVER	45940
9	6	SCREW HD C.S. M6X16	
10	1	O-RING 89X3	45880
11	1	MAIN BEARING HOUSING	45822
12	1	RETAINING RING 80X2.5	45914
13	1	OIL SEAL 60X80X8	45925
14	4	NUT-HEX M8	
15	4	TOOTHED SPRING WASHER I8.4	
16	1	OIL PUMP	45817
17	1	GASKET-OIL PUMP	45839
18	3	LOCK WASHER 8	
19	1	SCREW HEX M6X20	
20	2	SCREW HEX M6X30	

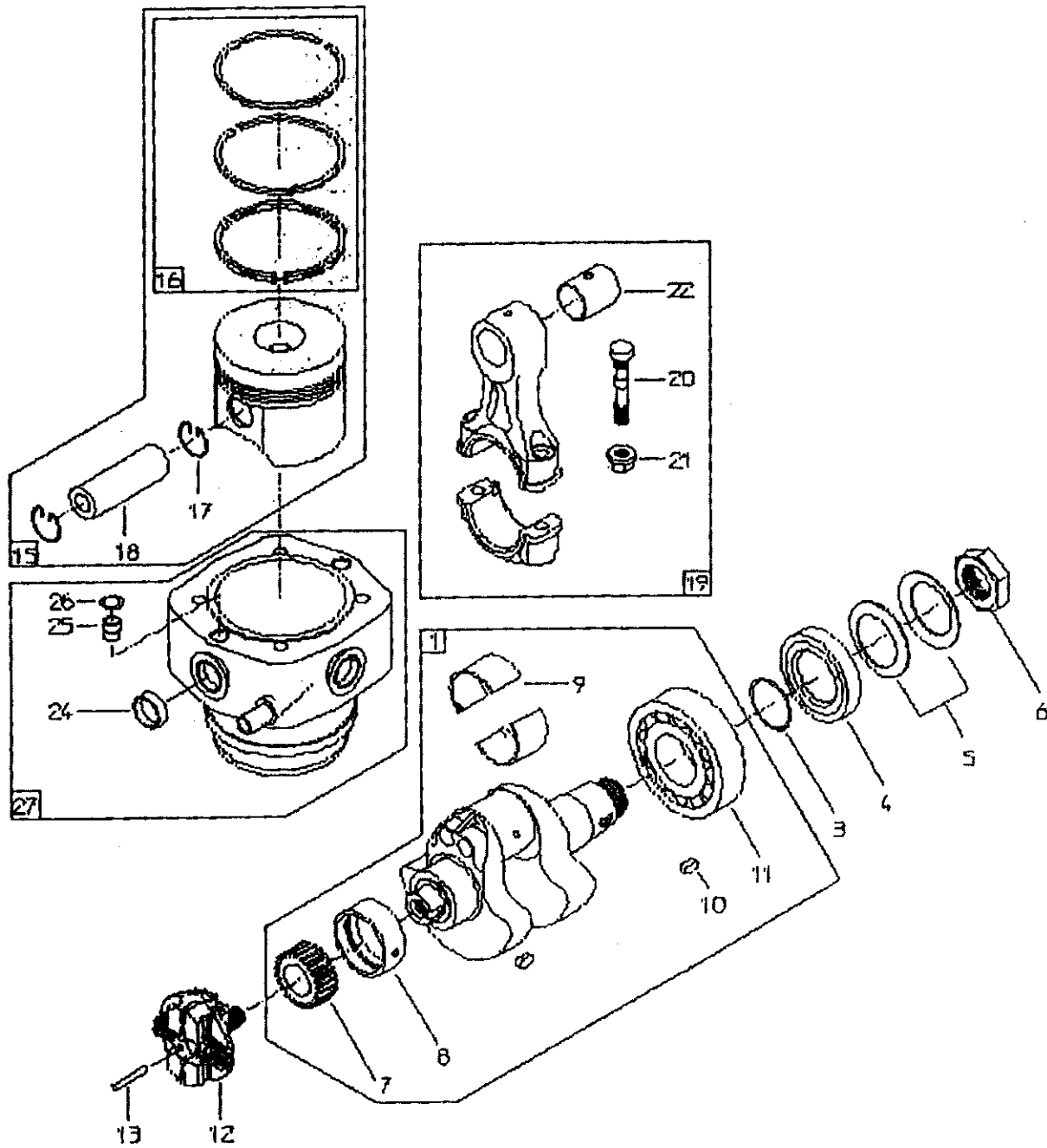

Crankshaft; Cyl./Piston

Pos.	Pres.	Designation	
1	1	CRANKSHAFT ASSY	48609
3	1	O-RING 32X2	45878
4	1	ANGLE RING	45736
5	2	WASHER-BELLEVILLE 52X36X1.2	45859
6	1	FLYWHEEL NUT	45725
7	1	GEAR	45697
8	1	MAIN BUSHING STD	45851
8	1	MAIN BUSHING .25"	45852
8	1	MAIN BUSHING .50"	45853
9	1	BEARING SHELL (PR) STD	45849
9	1	BEARING SHELL (PR) .25"	45850
9	1	BEARING SHELL (PR) .50"	45851
10	2	BEARING-MAIN F.S.	45857
11	1	GROOVED BALL BEARING 6307 C3	45918
12	1	GOVERNOR N=3000E	
12	1	GOVERNOR N=3000	
12	1	GOVERNOR N=3600E	
12	1	GOVERNOR N=2000	
13	1	PIN 4X27.8	45926
15	1	PISTON ASSY	48610
16	1	PISTON RING SET	47249
17	2	LOCK-PISTON PIN A22X1.5	45933
18	1	PISTON PIN	45617
19	1	CONNECTING ROD	45820
20	2	CONROD BOLT	45710
21	2	COLLAR NUT	45724
22	1	BUSHING E	45701
24	4	PLUG-WELCH 22MM	37653
25	2	WATER TRANSFER PIPE	45981
26	2	O-RING 10X2.2	45877
27	1	CYLINDER ASSY	48611

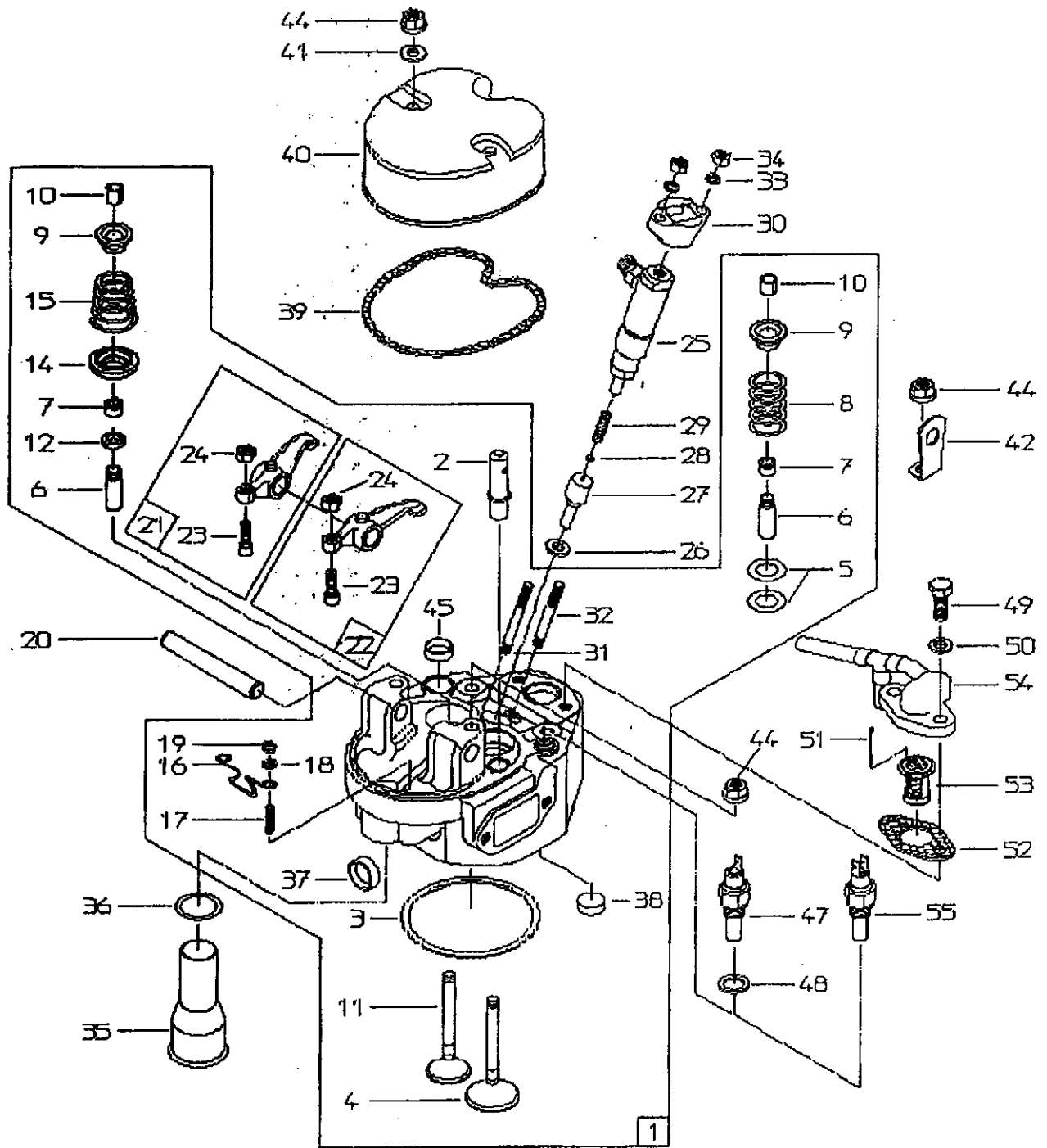

Cylinderhead

Pos.	Pres.	Art.No.	Designation	
1	1		CYLINDER HEAD ASSY	48612
2	1		BREATHER VALVE	45812
3	1		CYLINDER HEAD GASKET	45849
3	1		CYLINDER HEAD GASKET 1,3MM	
3	1		CYLINDER HEAD GASKET 1,4MM	
4	1		VALVE CONE IN	45693
5	2		WASHER	45970
6	2		VALVE GUIDE	45622
7	2		VALVE SEAL W/OUT SPRING 80 803	45903
8	1		PRESSURE SPRING	45861
9	2		RETAINER-VALVE SPG	45746
10	2		VALVE COTTER	45963
11	1		VALVE CONE 4x	45624
12	1		RING	45739
14	1		ROTOCAP-VALVE K85 2901.01/540	45785
15	1		PRESSURE SPRING	45862
16	1		SPRING-RETAINING	45865
17	2		STUD M5X10	
18	2		WASHER 5.3	
19	2		NUT-HEX 5MM	
20	1		BOLT <i>SWAPT, Rock 69</i>	45215
21	1		ROCKER ARM	45807
22	1		ROCKER ARM	45806
23	2		PRESSURE SCREW	45722
24	2		NUT-HEX 7MM	
25	1		FUEL INJECTOR	45758
26	1		WASHER	47707
27	1		NOZZLE-FUEL INJ.	45760
28	1		LOCATOR-NOZZLE	45761
29	1		SPRING-NOZZLE	45763
30	1		FLANGE	45971
31	1		STUD M6X50	
32	1		STUD M6X45	
33	2		LOCK WASHER 6	
34	2		NUT-HEX 6MM	
35	1		PUSH ROD TUBE	45946
36	1		O-RING 24X3.5	45844
37	2		PLUG-WELCH 22MM	37653
38	1		PLUG-WELCH 18MM	24364
39	1		GASKET-ROCKER COVER	45834
40	1		ROCKER COVER	45810
41	2		WASHER BM8	80229
42	1		HANGER	45968
44	6		COLLAR NUT	
45	1		PLUG-WELCH 18MM	24364
48	1		COPPER WASHER A14X20X1.5	
49	2		SCREW HEX M8X20	
50	2		SPRING WASHER B8	
51	1		SPLINT 2X16	45907
52	2		GASKET	45833
53	1		THERMOSTAT 40°C	45786
54	1		CONNECTING PIECE	45993
55	1		TEMPERATURE SWITCH 85° 2 POLE	45790

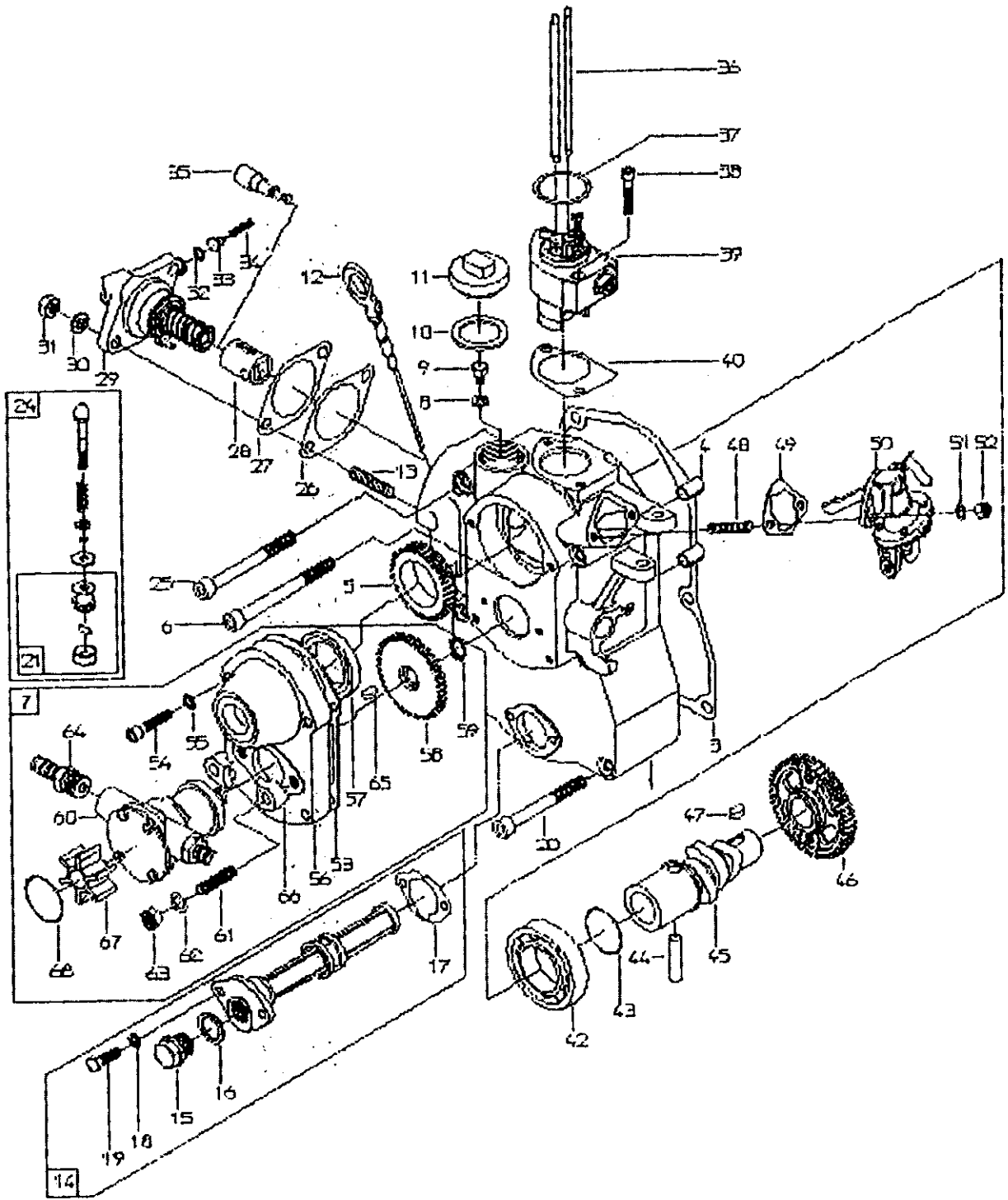

Gear end cover

Pos.	Pres.	Designation	
1	1	COVER GEAR	45814
3	1	GASKET-GEAR COVER	45835
4	2	PIN-ROLL 10X16	45930
5	1	GEAR	45695
6	1	SCREW HEX M8X90	
7	1	COOLWATERPUMP ASSY	
8	1	SPRING WASHER A6	
9	1	SCREW HEX	45717
10	1	GASKET	45886
11	1	CAP-OIL FILLER	45935
12	1	DIPSTICK	45930
13	2	STUD M8X20	
14	1	OILFILTER	45823
15	1	PLUG-OIL DRAIN 3/8"	45921
16	1	COPPER WASHER A17X23X1.5	
17	1	GASKET	45840
18	2	COPPER WASHER A6X10X1.5	
19	2	SCREW HEX M8X20	
20	2	SCREW HEX M8X70	
21	1	HANDLE	45962
24	1	PRIMER ASSY	4860
25	3	SCREW HEX M8X80	
26	1	SHIM 0.2	45976
26	1	SHIM 0.5	45977
26	1	SHIM 0.35	45978
26	1	SHIM 1MM (STEEL)	45979
27	1	GASKET	45842
28	1	ROLLER TAPET	45757
29	1	FUEL INJECTION PUMP 1Q65/38	45749
30	2	SPRING WASHER B8	
31	2	NUT-HEX M8	
32	1	WASHER	45750
33	1	PRESSURE VALVE	45752
34	1	SPRING-DEL. VALVE	45751
35	1	FUEL PUMP ELEMENT	45754
36	2	PUSH ROD	45619
37	1	O-RING 32X3	45885
38	2	SCREW HEX M5X30	
39	1	COMPRESSION RELEASE	45792
40	1	GASKET-GEAR COVER	45838
40	1	GASKET	45843
42	1	GROOVED BALL BEARING 6007	45917
43	1	O-RING 32.7X1.3	45889
44	1	BOLT	45616
45	1	CAMSHAFT	45816
46	1	GEAR	45698
47	1	FITTING-KEY A6X4X12	45927
48	1	STUD M6X20	
49	1	GASKET	45876
50	1	FUEL FEED PUMP	45610
50	1	RETAINING RING 12X1	45912
51	2	LOCK WASHER A6	
52	2	NUT-HEX 6MM	
53	1	GASKET	45975
54	4	SCREW HEX M6X25	
55	4	TOOTHED SPRING WASHER J6.4	
56	1	COVER	45800
57	1	OIL SEAL 34.8X50X7/7.5 W01	45924
58	1	GEAR	45696
60	1	COOLING WATER PUMP	45765
61	2	STUD M8X22	
62	2	LOCK WASHER A8	
63	2	NUT-HEX M8	

IMPELLER KIT 45766

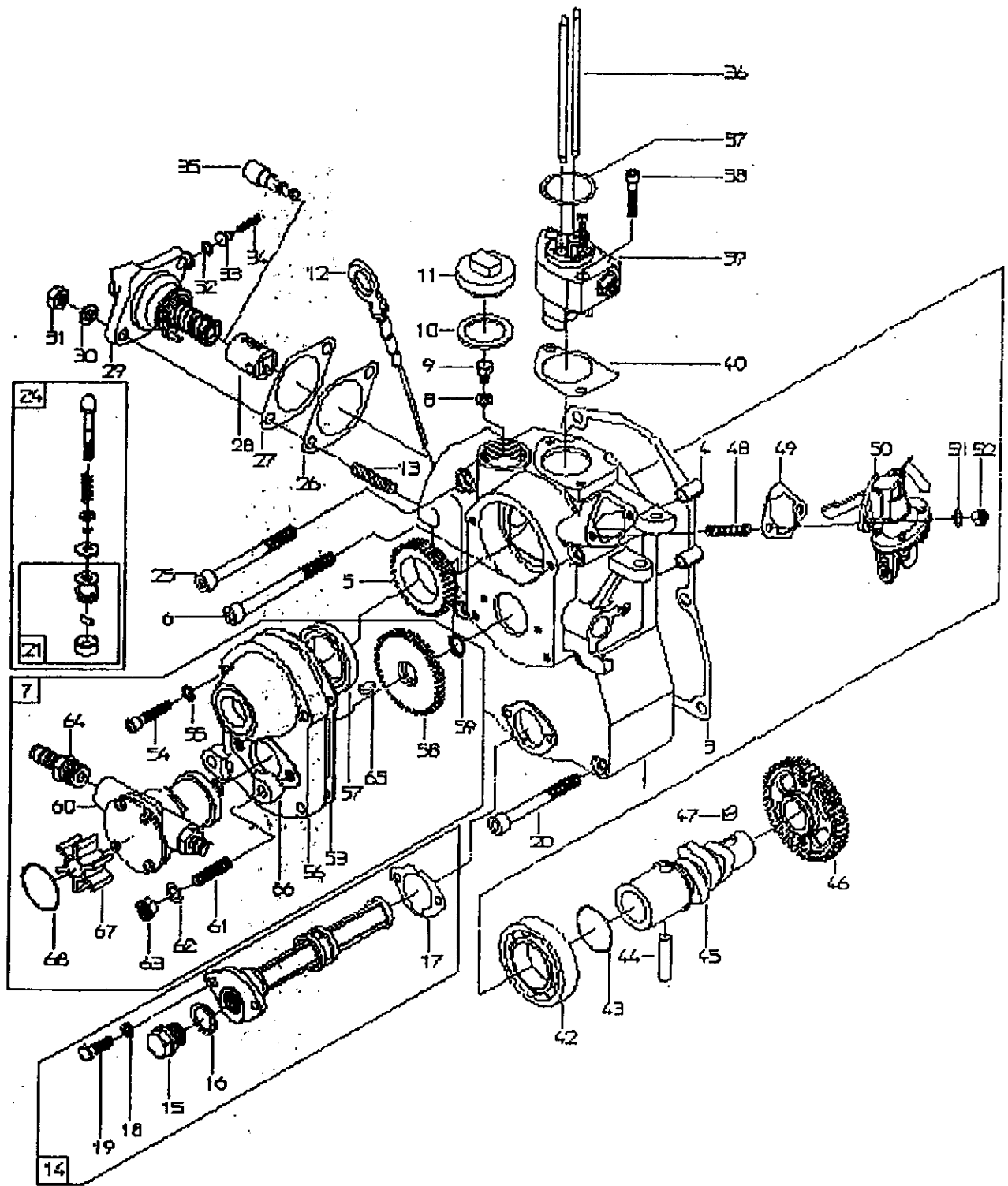

Gear end cover

Pos.	Pres.	Designation	
64	2	CONNECTOR GES 10-3/8"	418994
65	1	FITTING-KEY A3X3X12	45929
66	2	CLAMP	45768
67	1	IMPELLER	45766 KIT
68	1	GASKET	33032

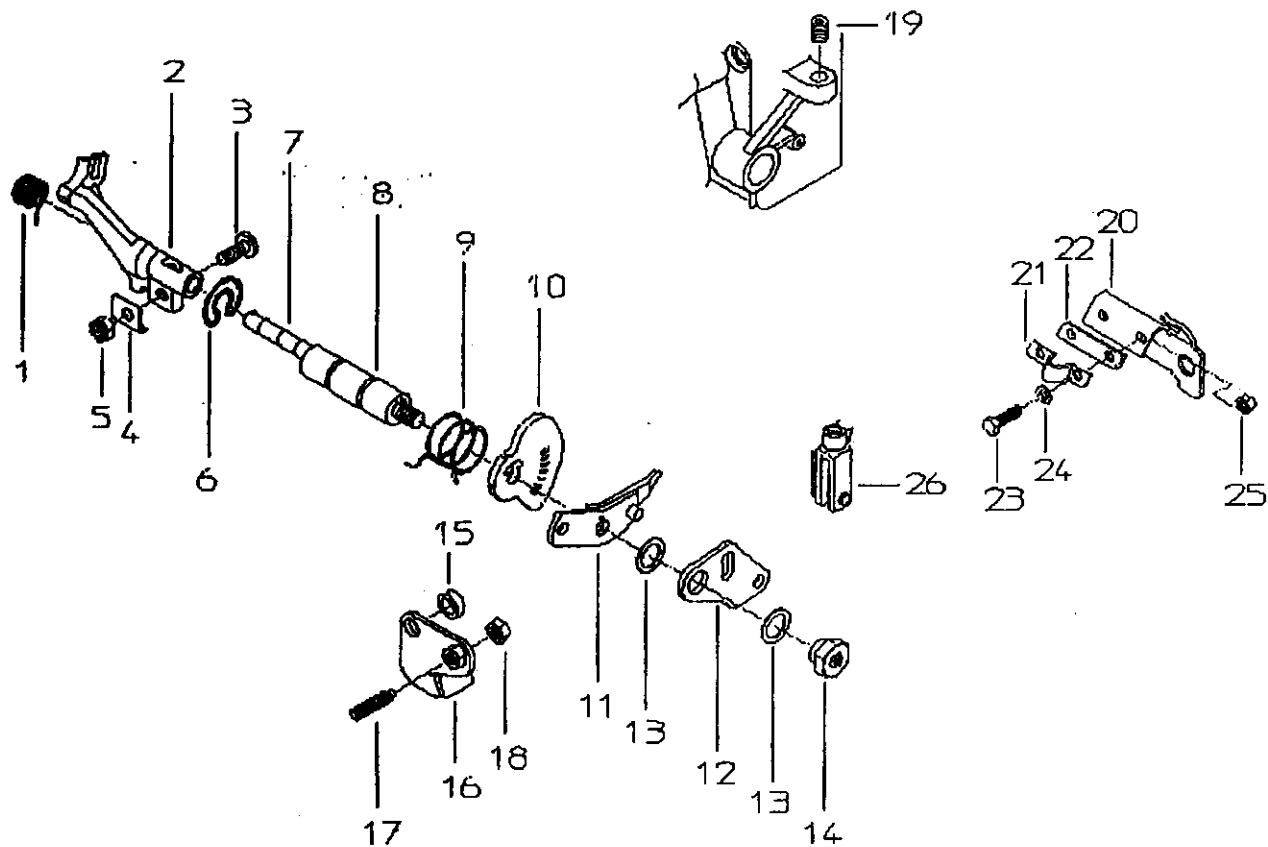

Governor linkage and controls

Pos.	Pres.	Designation	
1	1	SPRING-RETURN	45863
2	1	CONTROL LEVER	45799
3	1	ADJUSTING SCREW	45721
4	1	LOCKING PLATE	45975
5	1	SPRING-STOP NUT-HEX M6	45730
6	1	CLIP-RETAINING	45867
7	1	ECCENTRIC SHAFT	45613
8	1	O-RING 10X2.2	45877
9	1	TORSION SPRING	45864
10	1	PLATE-CONTROL	45945
* 11	1	LEVER	45939
* 12	1	LEVER	45938
13	2	WASHER	45744
14	1	BEARING NUT	45726
15	1	BUSHING	45704
16	1	BRACKET	45958
17	1	SCREW-HEADLESS M6X25	45934
18	1	NUT-HEX 6MM	
19	1	STUD BOLT M8X10	
20	1	BRACKET	45960
21	1	CLAMP	45949
22	1	SHIM	45950
23	2	SCREW HEX M5X16	
24	2	SPRING WASHER A5	
25	2	NUT-HEX 5MM	
26	1	CONNECTOR	45788

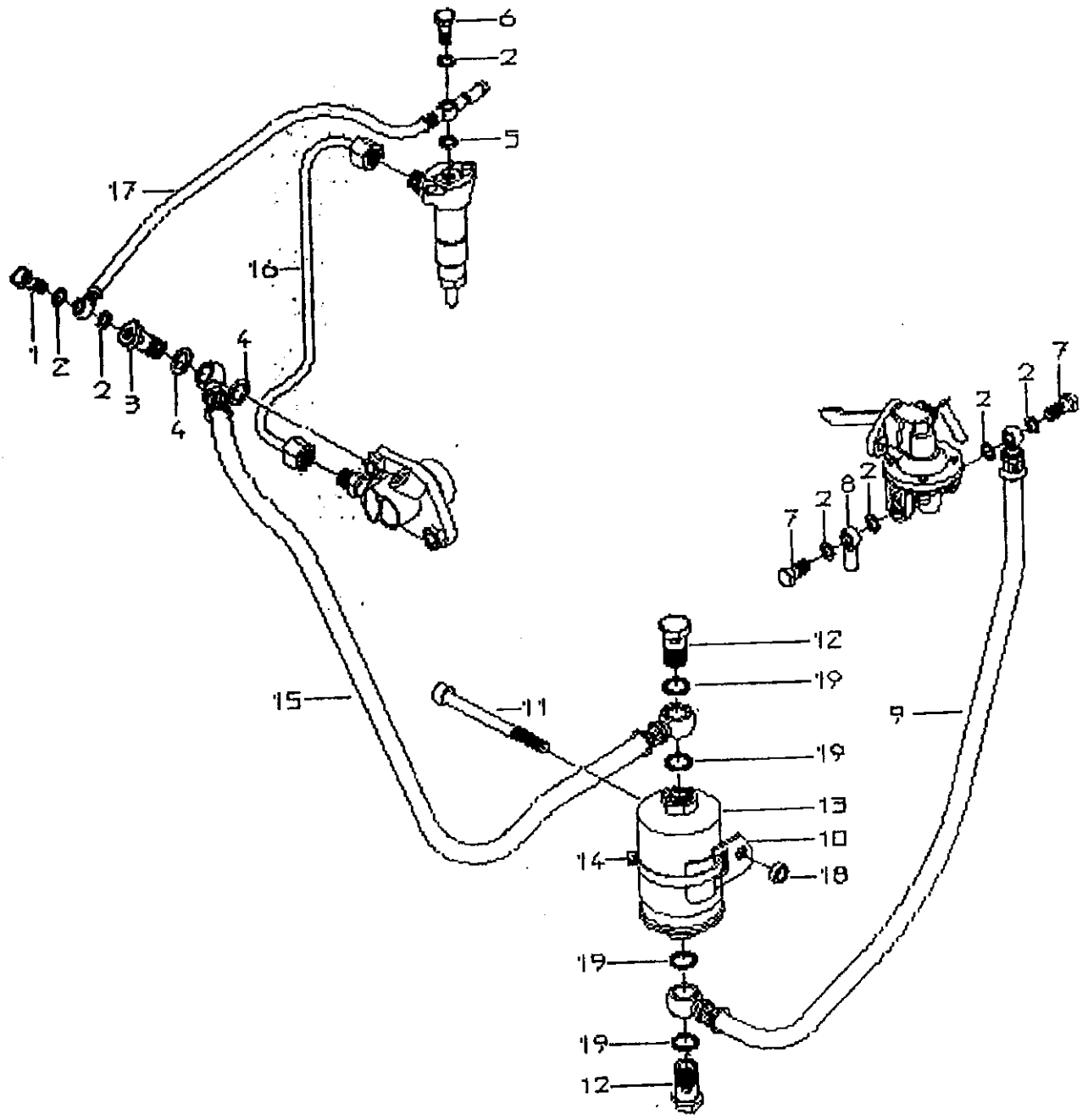

Fuel lines

Pos.	Pres.	Designation	
1	1	BANJO-BOLT M8X1	45931
2	7	COPPER WASHER A8X12X1	47709
3	1	BANJO BOLT	45731
4	2	COPPER WASHER A12X18X1.5	36923
5	1	GASKET	45887
6	1	BANJO-BOLT M8X1	45931
7	2	BANJO BOLT M8	45735
8	1	CONNECTOR-FUEL LINE	45732
9	1	FUEL PIPE	45987
10	1	BRACKET	45965
11	1	SCREW HEX M8X90	
12	2	BANJO-BOLT A8 M14X1.5	45932
13	1	FUEL FILTER 4 NO	44769
14	1	BRACKET-CLAMP 40-60 4 NO	
15	1	FUEL PIPE	45988
16	1	FUEL PRESSURE PIPE	45984
17	1	FUEL PIPE	
18	1	BUSHING	45704
19	4	COPPER WASHER A14X18X1.5	

- 45952 - CLAMP

- FUEL FILTER # 44769 IS METAL AND IT HAS HOSE BARBS,
 - NO FILTER WITH BANJO BOLT FITTINGS IS AVAILABLE.

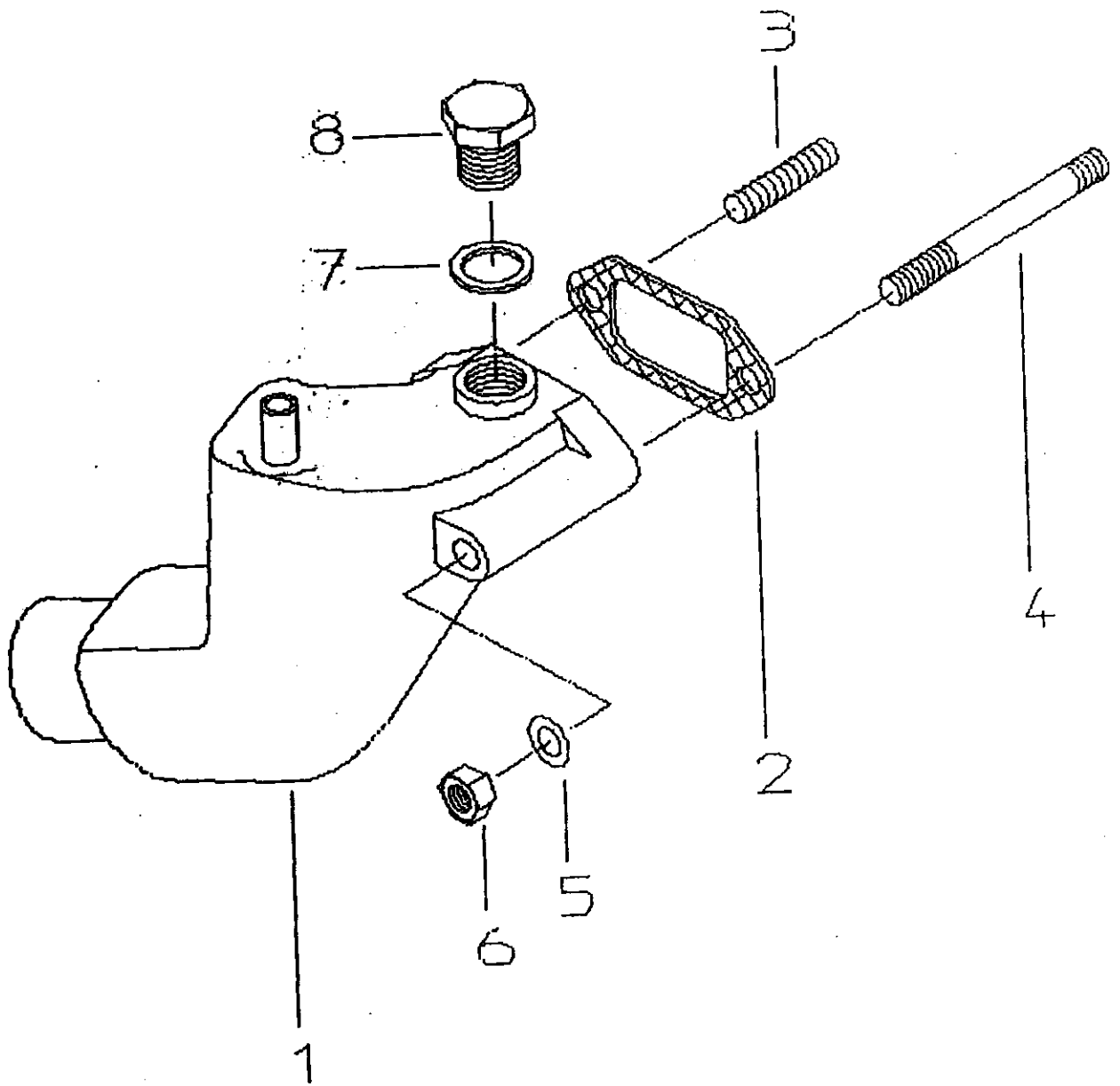

Exhaust silencer

Pos.	Pres.	Designation	
1	1	INJECTION ELBOW	45798
2	1	GASKET-AIR CLN. MTG	45827
3	1	STUD M8X25	15730
4	1	STUD M8X70	
5	2	LOCK WASHER A8	
6	2	NUT-HEX M8	
7	1	COPPER WASHER A16X22X1.5	33280
8	1	PLUG SCREW M16X1.5	22205

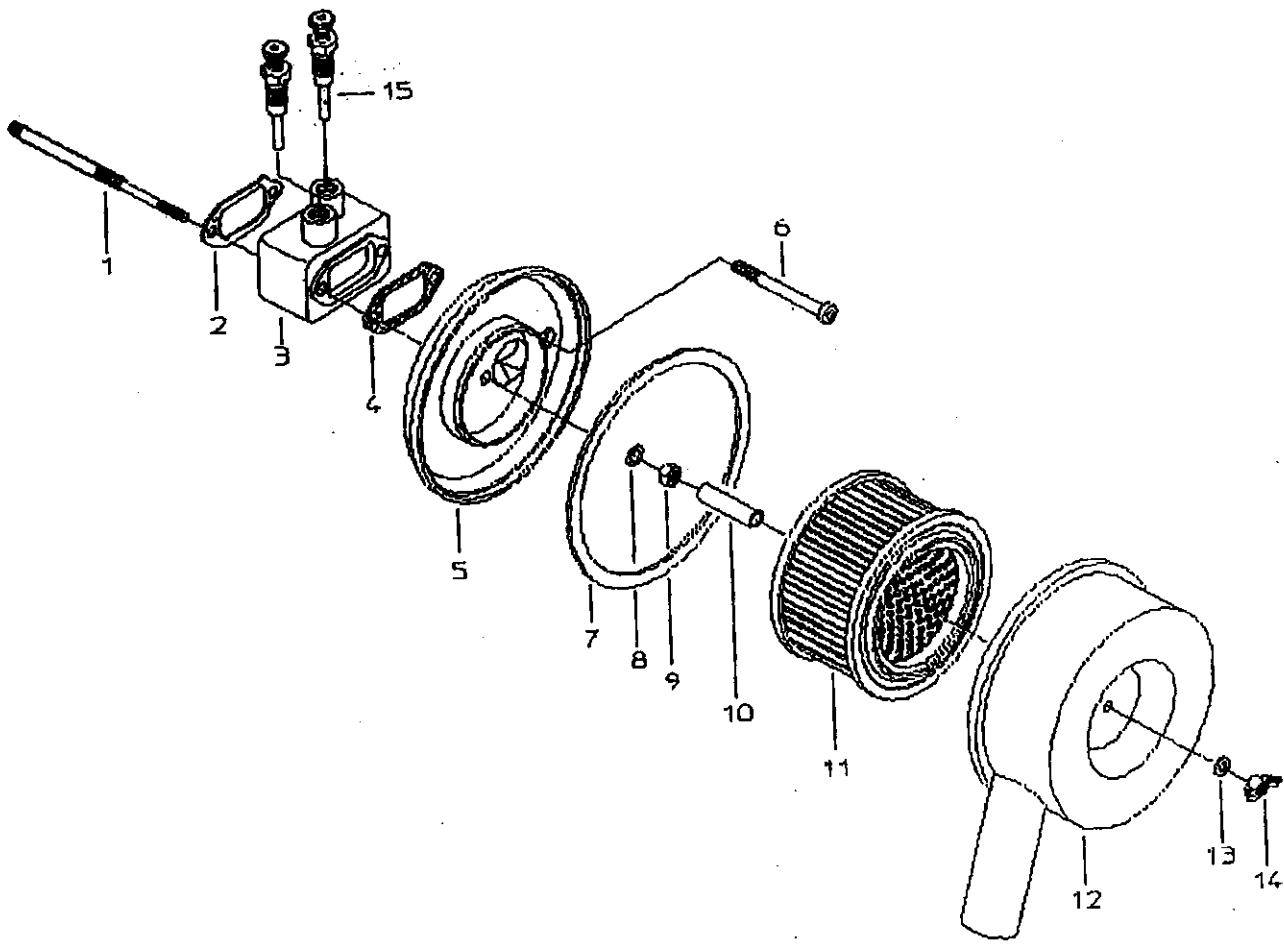

Air cleaner

<i>Pos.</i>	<i>Pres.</i>	<i>Designation</i>	
1	1	STUD	45720
2	1	GASKET	45847
3	1	INTAKE ELBOW	45796
4	1	GASKET-AIR CLN. MTG	45837
5	1	LOWER PART	45802
6	1	SCREW HEX M8X80 31913	
7	1	GASKET	46992
8	1	LOCK WASHER B8	
9	1	NUT-HEX 10/10	
10	1	DISTANCE SLEEVE	45738
11	1	AIR FILTER ELEMENT	45777
12	1	AIR FILTER	45828
13	1	WASHER 6.4	
14	1	WING NUT	45728
15	2	GLOW PLUG 12V/12A 142 MJ	45789

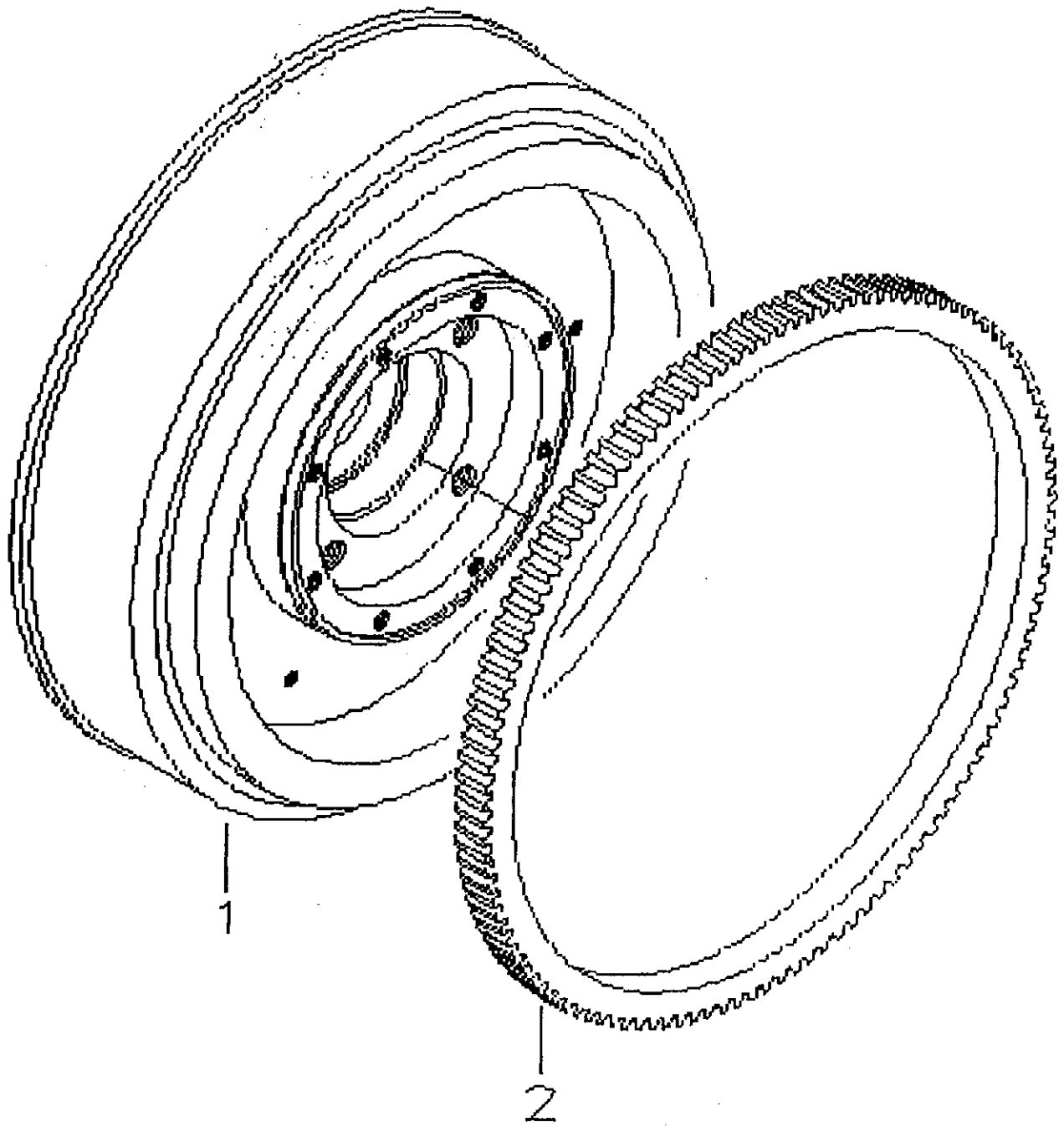

Flywheel

<i>Pos.</i>	<i>Pres.</i>		<i>Designation</i>
1	1		FLYWHEEL
2	1		GEAR RING
			45827
			45699

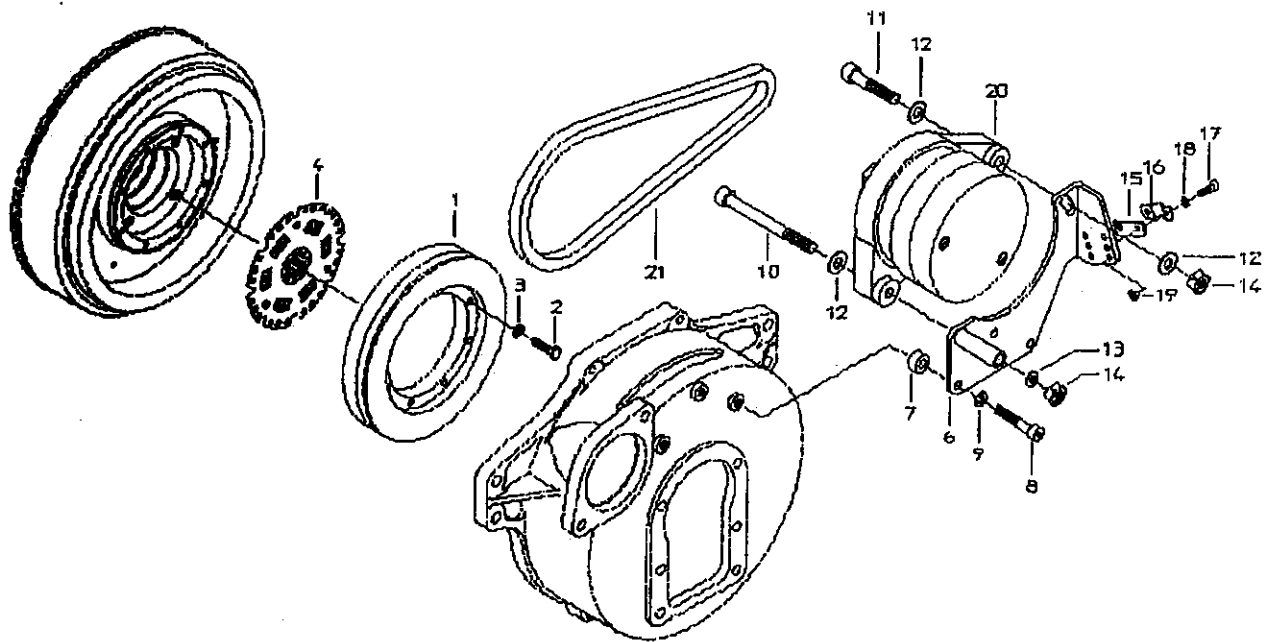

Alternator assy.

Pos.	Pres.	Designation	
1	1	PULLEY	45705
2	8	SCREW HEX M6X25	
3	8	LOCK WASHER 6	
4	1	TORSIONAL DAMPER	45609
6	1	BRACKET	45703 45966
7	3	DISTANCE BUSH	45703
8	3	SCREW HEX M8X45	
9	3	SPRING WASHER B8	
10	1	SCREW HEX M10X100	
11	1	SCREW HEX M10X50	
12	3	WASHER 10.5	
13	1	SPRING WASHER A10	
14	2	NUT-HEX 10MM	
15	1	SHIM	13870
16	1	CLAMP	13325
17	2	SCREW HEX M5X16	
18	2	SPRING WASHER A5	
19	2	NUT-HEX 5MM	
20	1	ALTERNATOR	45783
21	1	V-BELT SPZ 800 LW <i>no use more</i>	46268

BELT - 46268

TIME DELAY - 46043

K1 RELAY - 37833

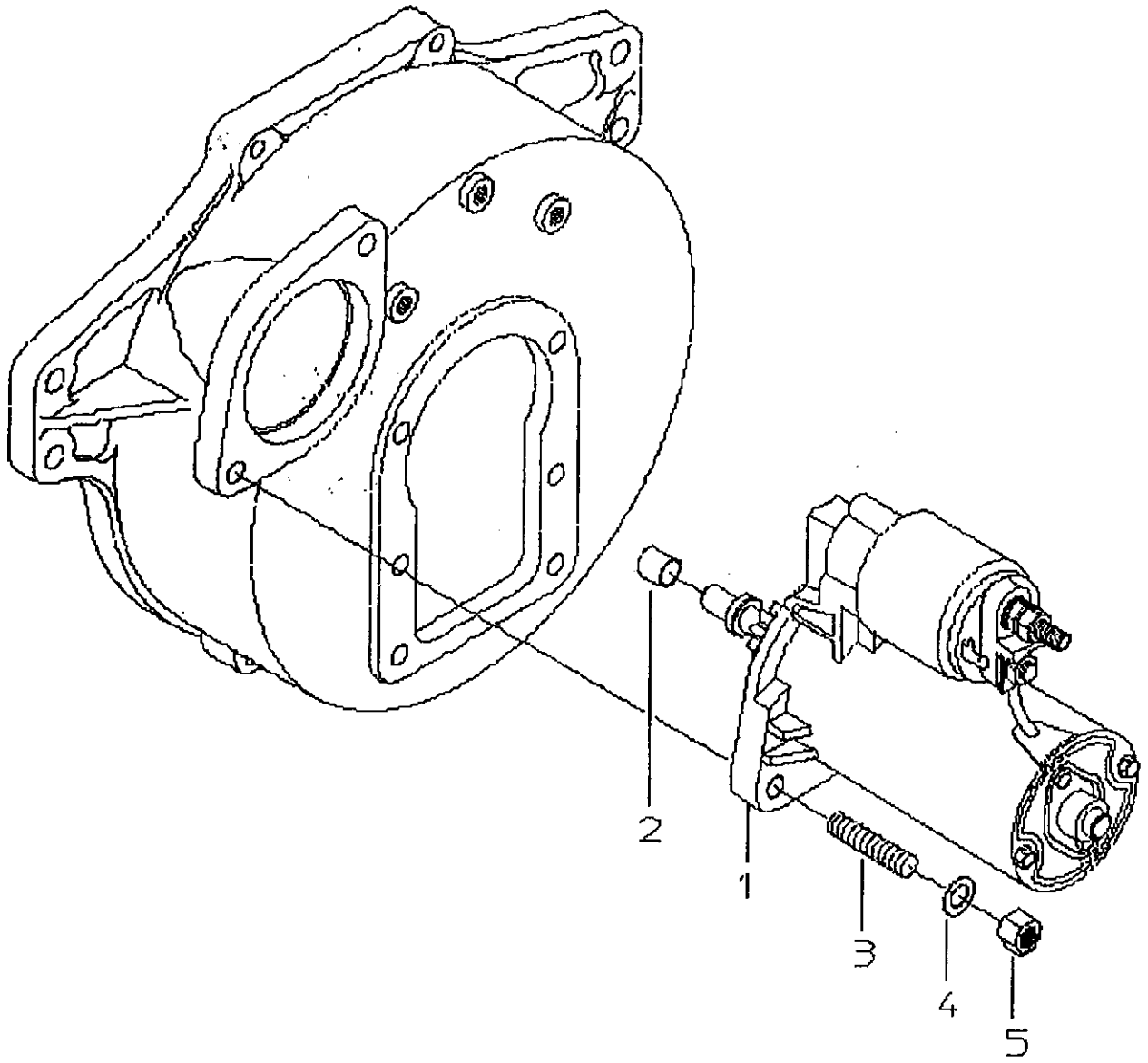

Starter motor

<i>Pos.</i>	<i>Pres.</i>	<i>Designation</i>
1	1	STARTER MOTOR 12V
2	1	BUSHING
3	2	STUD M10X25
4	2	LOCK WASHER A10
5	2	NUT-HEX M10 SW15

45784

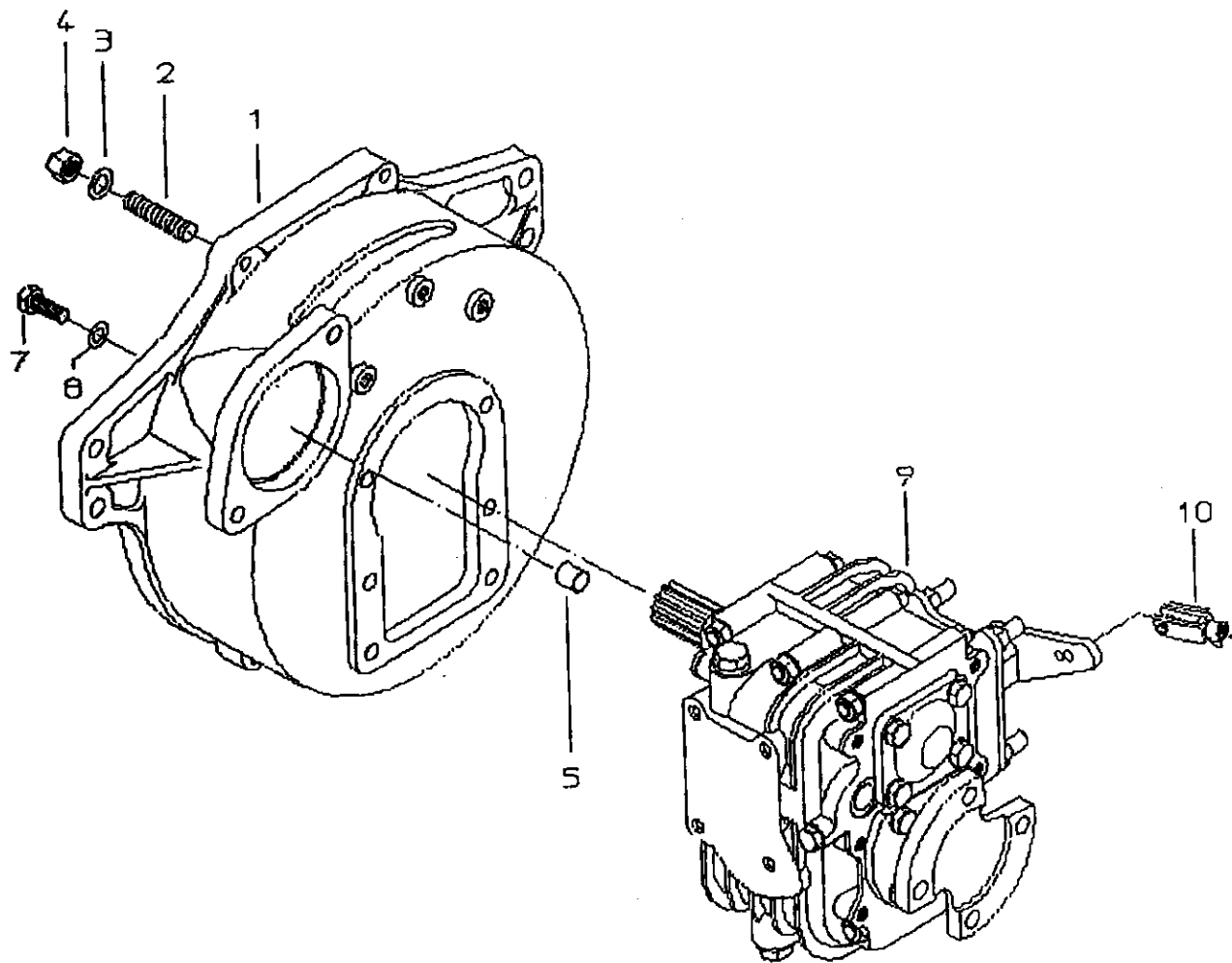

Spacer assy.

Pos.	Pres.	Art.No.	Designation
1	1		FLANGE
2	4		STUD M10X25
3	4		LOCK WASHER A10
4	4		NUT-HEX M10 SW15
5	1		BUSHING
7	6		SCREW HEX M8X20
8	6		LOCK WASHER A8
9	1		REDUCTION GEAR-BOX HBW40-2R
10	1		CONNECTOR

45804

43336

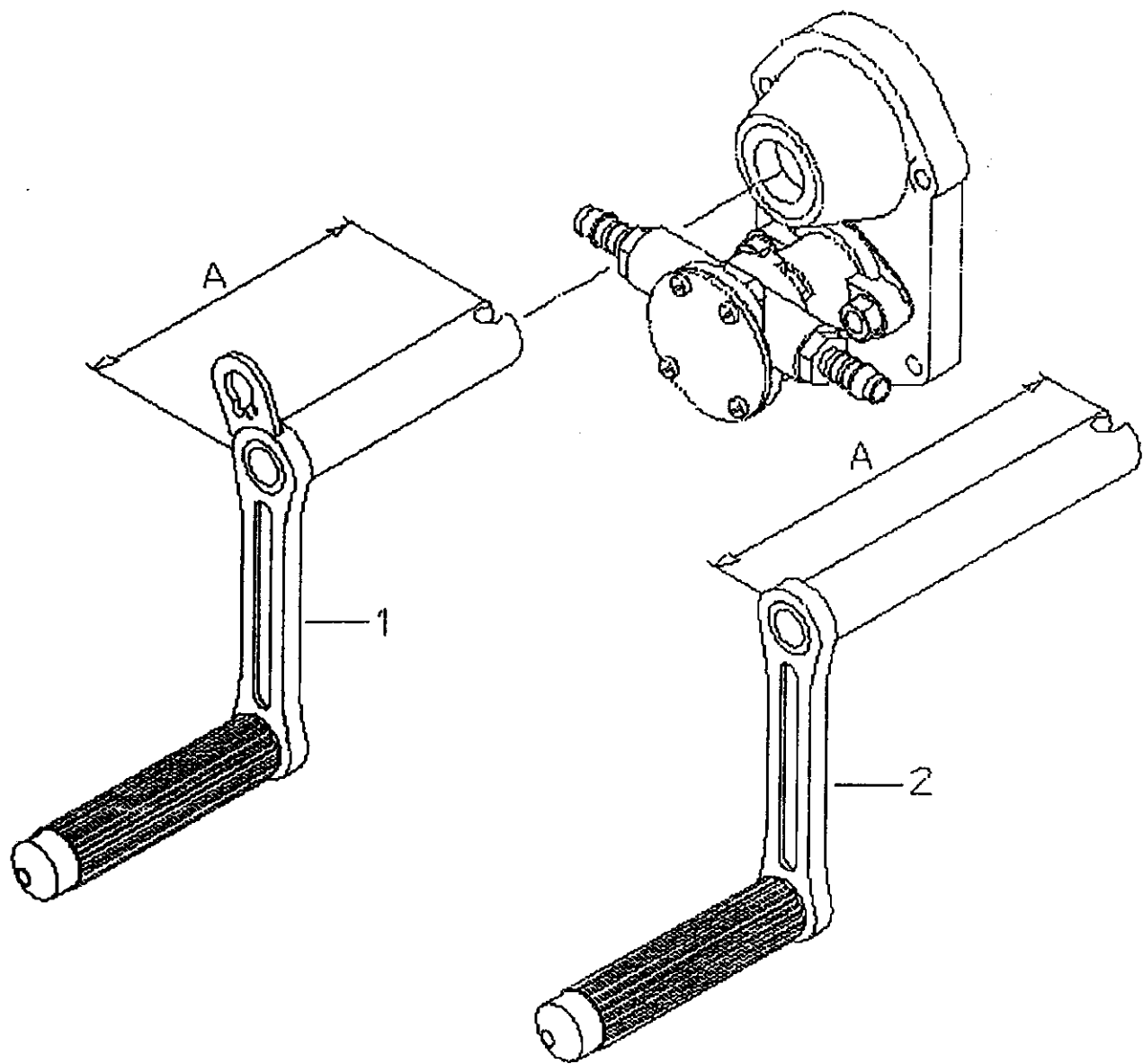

Crankhandle

Pos.	Pres.	Designation
1	1	CRANK-HANDLE 105 mm 45608

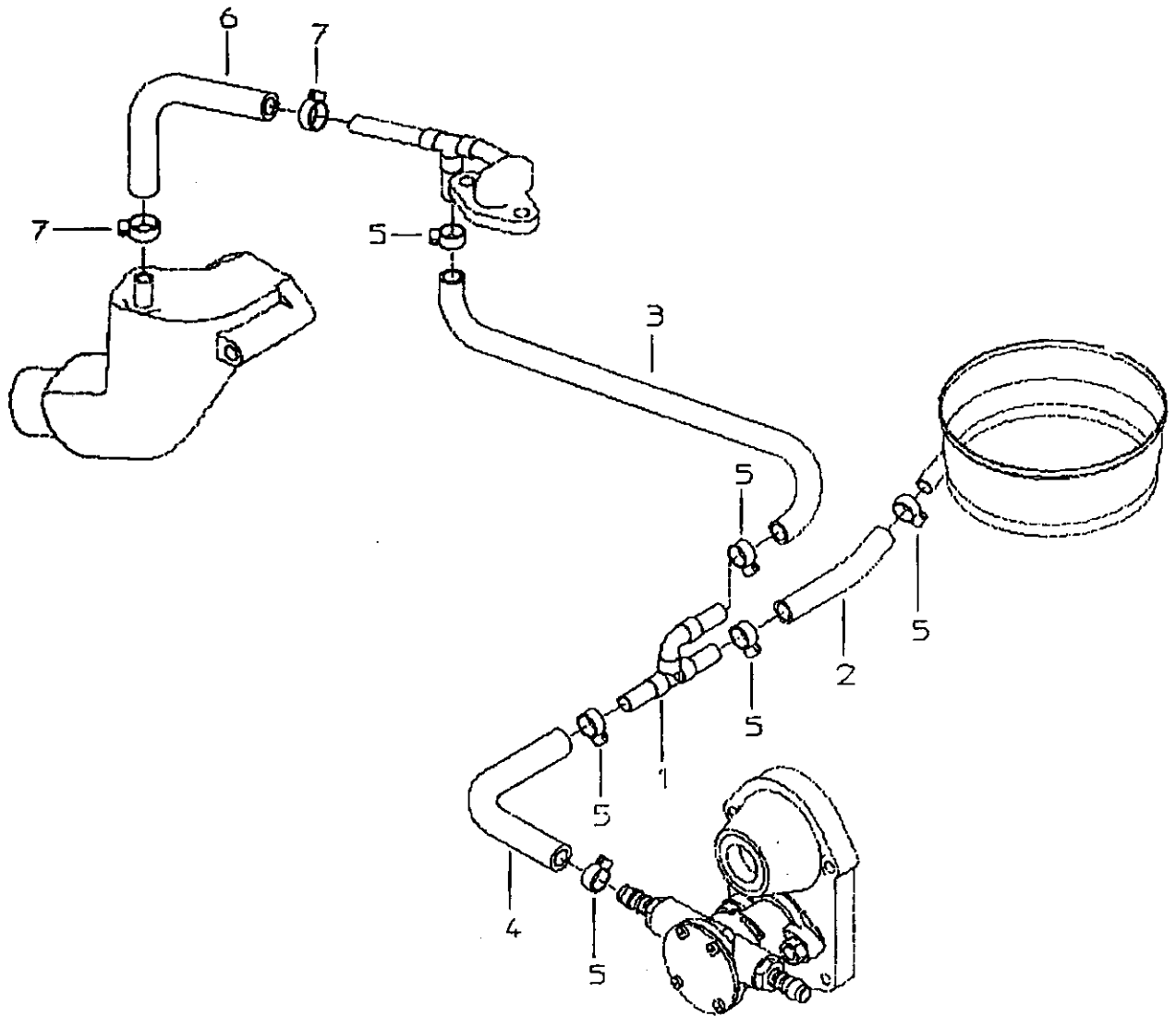

Cooling water circulation

Pos.	Pres.	Designation	
1	1	DISTRIBUTOR	45892
2	1	HOSE 9X2.5X40	45895
3	1	HOSE 9X2.5X260	45896
4	1	HOSE Ø10/50x120	45894
5	6	BRACKET-CLAMP 8-16/9	
6	1	HOSE Ø10/50x120	
7	2	BRACKET-CLAMP 12-22/9	

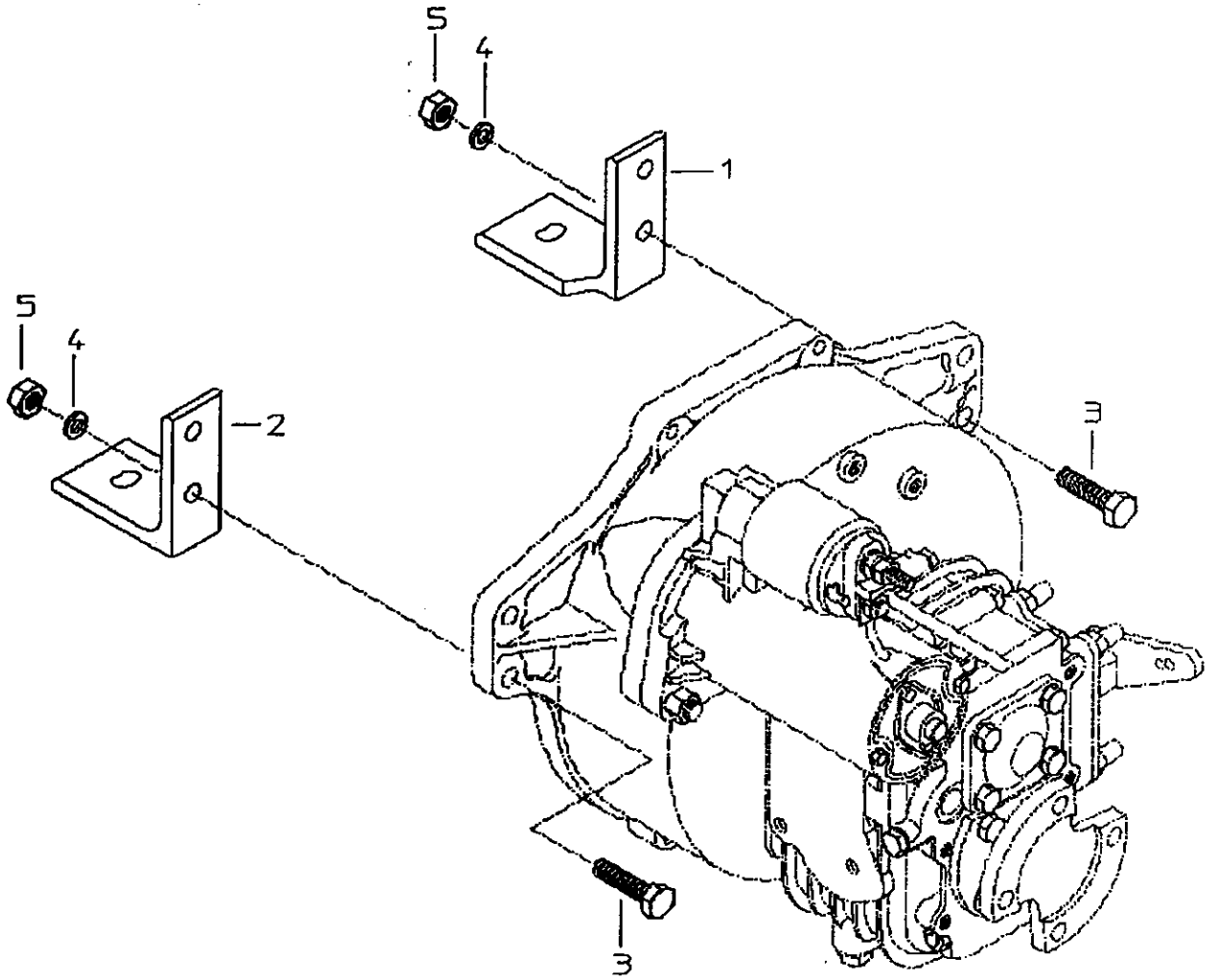

Vibration mounting

<i>Pos.</i>	<i>Pres.</i>	<i>Designation</i>
1	1	ENGINE MOUNT LEFT
2	1	ENGINE MOUNT RIGHT
3	4	SCREW HEX M10X40
4	4	SPRING WASHER A10
5	4	NUT-HEX 10MM

Joint set

<i>Pos.</i>	<i>Pres.</i>	<i>Designation</i>
1	1	GASKET SET 45825

Panel, remote control PN 44576

Keyswitch PN 24777

Buzzer PN 13355

Hour meter PN 42388