

Extremely compact, 1800-rpm smooth & quiet...

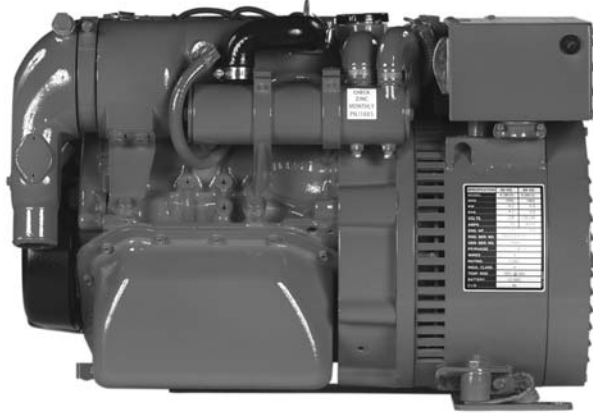

7.0 BCGD Marine Gasoline Generator

The Most Compact 7.0kW Available

The 1800-rpm, 7.0 BCGD gasoline generator has the smallest envelope available.

Quiet

The 7.0 BCGD operates at a quiet 1800-rpm. So quiet, it does not require a sound enclosure.

Smooth Operation

Operating with 3-cylinders and a balance shaft that virtually eliminates vibration, the 7.0 BCGD is an extremely smooth running generator set.

Durable and Reliable

The 7.0 BCGD runs at 28% of its maximum engine speed, so the owner can expect more durability and reliability.

Easy Maintenance

To minimize engine maintenance, the 7.0 BCGD is fresh water cooled and equipped with a simple control system. Easy access to servicing points allows easy installation and routine maintenance.

Five Year Limited Warranty

The 7.0 BCGD is backed by Westerbeke's 5-year limited warranty. The presence of Westerbeke in over 65 countries around the world provides customers with easy access to parts, service and technical support worldwide. Established in 1937, Westerbeke is committed to providing its customers with quality products and unequalled after sales support.

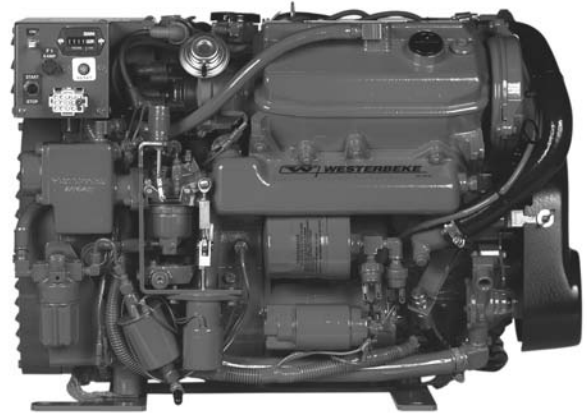

7.0 BCGD Marine Gasoline Generator

Standard Features

- Simple, start/stop control panel with running hour meter
- Electronic governing
- Overspeed protection
- Safety shut-downs—high coolant temperature, low oil pressure, high exhaust temperature
- Generator field adjustable to 50 or 60Hz
- A.C. circuit breaker
- Battery charger
- Fresh water cooling and coolant recovery tank
- 90° water injected exhaust elbow
- Belt-driven, raw water pump
- Vibration mounts
- Lube oil drain hose
- Belt guard
- Operators' manual and parts list
- EPA & CARB certified
- Meets U.S.C.G. regulation 33CFR-183



Optional Spare Parts Kit

Kit contents, as shown, may not correspond to the generator pictured.

Generator Design

DESIGN: Brushless, four pole, revolving field.
VOLTAGE REGULATION: Standard +/- 5% no load to full load.
FREQUENCY REGULATION: .5 Hz (1%) no load to full load.
INSULATION: Class "H" as defined by NEMA MG1-1.66.

TEMPERATURE RISE: Within NEMA MG1-22.40 operating at full load.
COOLING: Cast centrifugal blower, direct connected.
ELECTROMAGNETIC INTERFERENCE LEVEL: Exceeds requirements for most marine radio-telephones and standard TV's.

Model	Electrical Characteristics				Ratings		Engine		
	Volts	Amps	Hertz	Phase	Wire	Power Factor	kW	RPM	Start
7.0 BCGD-614	120	58.3	60	1	4	1.0	7.0	1800	Remote
5.8 BCGD-514	230	25.2	50	1	4	1.0	5.8	1500	Remote

Specifications

Number of Cylinders	3 cylinder, vertical in-line
Type	4 cycle
Displacement	40.3 cu. in. (.66 liter)
Bore and stroke	2.56" x 2.61" (65.0mm x 66.3mm)
Compression ratio	9.8:1
Rated RPM	60 Hz—1800 rpm 50 Hz—1500 rpm
HP @ 1800/1500 rpm	8.0/6.5 HP
Maximum angle of operation	Not to exceed 25° in all directions
Exhaust elbow conn.	2.0" OD (50.8mm)
Raw water conn.	0.75" OD (19.05mm)
Dry weight	336 lbs (152.4 kg)
Combustion system	Semi-spherical type
Aspiration	Naturally aspirated
Lubrication system	Forced pump
Cooling system	3 quarts (2.8 liter)
Full load fuel consumption	.86 GPH (3.26 LPH) @ 1800 rpm .72 GPH (2.73 LPH) @ 1500 rpm
Carburetor	Side draft type
Governor	Electronic
Lube oil filter	Full flow, spin on element
Lubricant capacity	2.5 quarts (2.4 liters)

Fuel transfer pump	Electric type
Fuel supply piping	.25" ID (6.35mm)
Starting motor	12 volt, 1.4 kW
Battery charging	17 amps, integral electric type
Cold cranking amps	105 amps @ 70 degrees F
Electrical system	12 volts DC, negative ground

Construction – Engine Components

Cylinder head	Aluminum
Cylinder block	Cast iron
Crankshaft	Forged crankshaft, four main bearings
Valves	Overhead, rotating type
Fuel system	Carbureted w/U.S.C.G. approved flame arrestor
Cooling system	Fresh water-cooled with heat exchanger
Exhaust manifold	Cast aluminum, fresh water-cooled

Optional Equipment

Remote start-stop panel
Ship-shore switch
Hydro-hush muffler and fittings
"A" on-board spare parts kit; "B" extended cruising spare parts kit
Anti-siphon valve for overboard cooling water discharge
Technical manual

Basic Dimensions inches (millimeters)

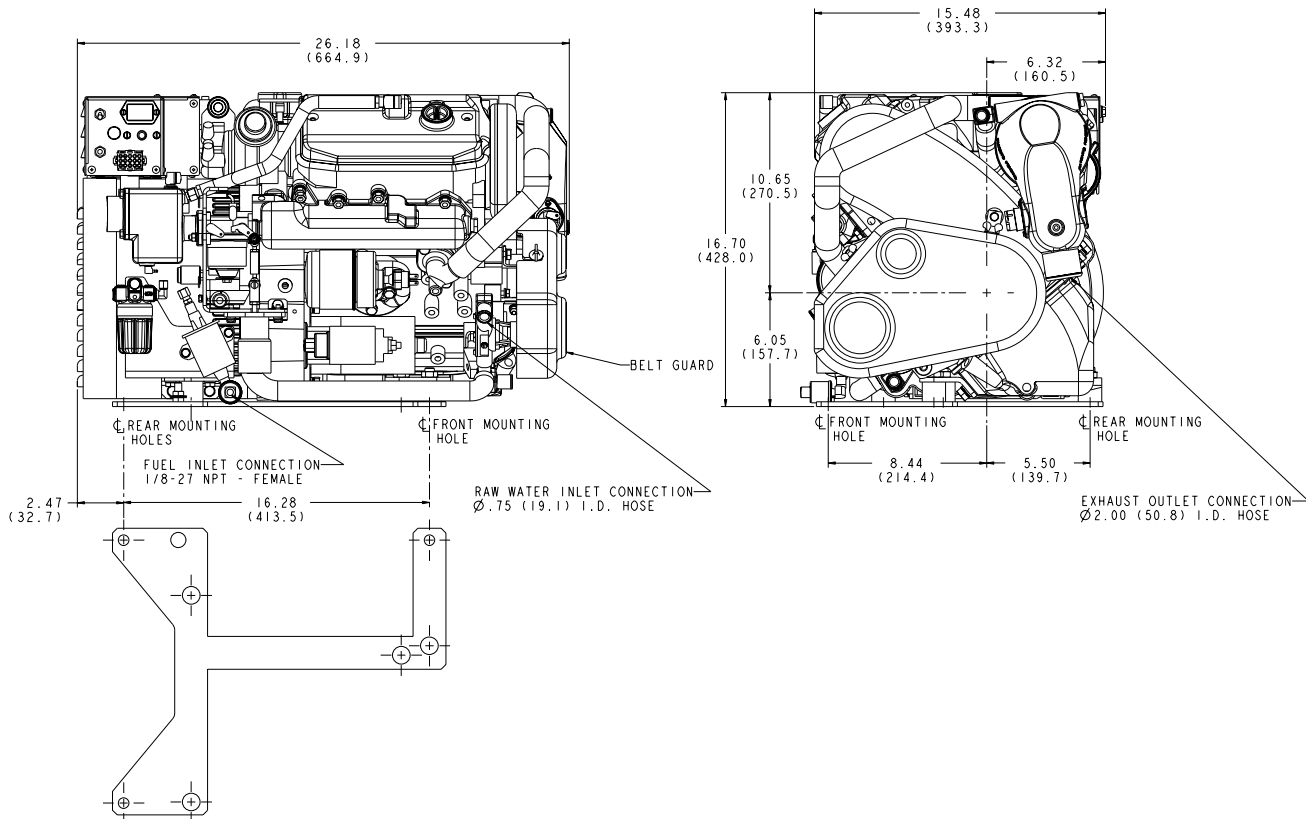

Drawings are for reference only and should not be used for installation. Detailed installation drawings are available upon request.