

WESTERBEKE

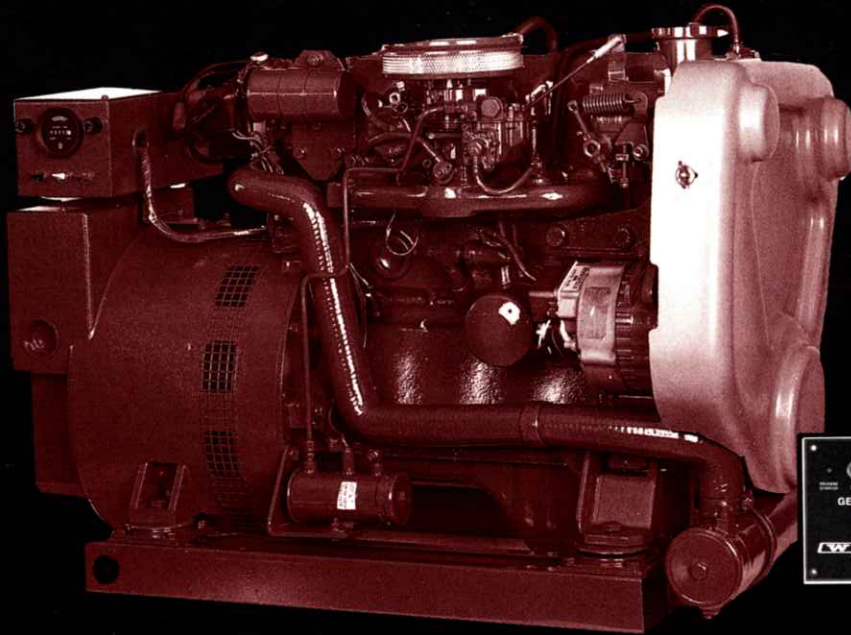

15kw
Marine Gasoline
Generator

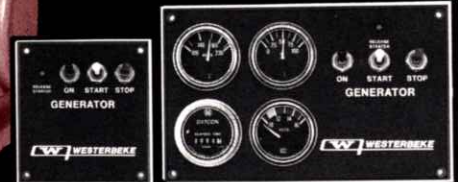

Remote Control Panel and Remote Instrument Panels are available as optional equipment.

The all-new brushless BT Series
Gasoline Gen-set . . . quiet, smooth,
. . . and very compact.

From its rugged overhead cam engine to its state-of-the-art electrical controls, the new 15 kw gasoline generator set is as modern as tomorrow. Boat owners can now cruise in quiet comfort knowing their electrical supply is completely assured.

For convenience, all A.C. electrical connections for the generator are grouped together on its back-end inside a louvered cover, including a terminal block for easy connection of voltages at either 60 or 50 hertz operation. An optional solid state voltage regulator is available. Its easily mounted plug-in connection and selector switch operate in tandem with the standard transformer regulation system.



Notice the compactness of the field assembly, which rotates at synchronous speed within the stationary armature. This assembly, together with a standard transformer or optional regulator maintains a constant voltage under all load conditions.



Although all in-line cylinder blocks may look alike, it is the upper and lower construction that tells the story. Westerbeke's in-line gas engine lower sections feature massive counter balanced crankshafts. Continuous loads are easily supported by two main bearings at each connecting rod.

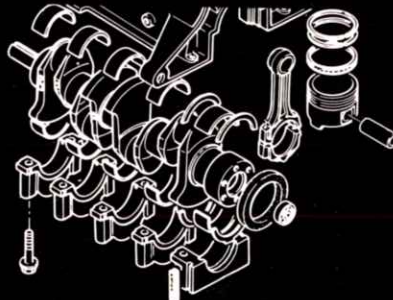

The alloy cylinder head has hemispherical combustion chambers with angled valves operated by an overhead camshaft. This configuration allows horizontal mounting of the electronic distributor, providing a low profile. A flood of fresh water coolant circulates through a heat exchanger to maintain even engine temperature without corrosion.

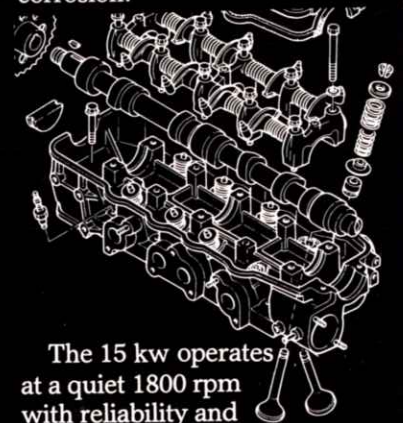

The 15 kw operates at a quiet 1800 rpm with reliability and low maintenance. **Uniquely Westerbeke!**

15 kw Gasoline Marine Generator Set

WESTERBEKE

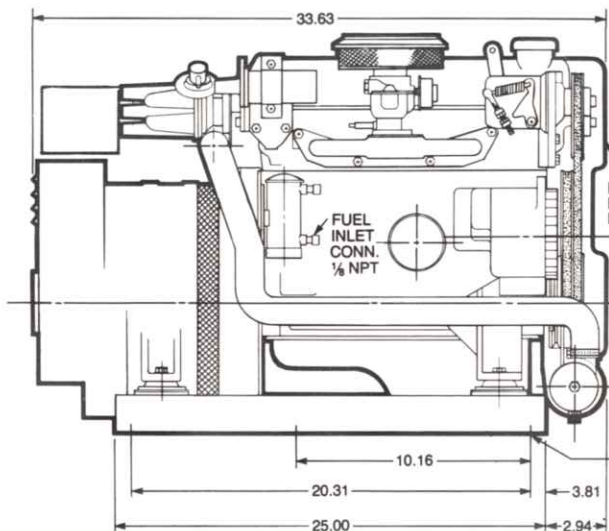

TECHNICAL DATA

DESIGN: Brushless, four pole, revolving field, self regulating, pre-lubricated single bearing design. (Optional full power take-off through rear of generator available.)

VOLTAGE REGULATION: Standard $\pm 5\%$ no load to full load. (With optional solid state voltage regulation $\pm 2\%$ no load to full load.)

FREQUENCY REGULATION: 3 Hertz (5%) no load to full load.

INSULATION: Class F as defined by NEMA MGI-1.65.

TEMPERATURE RISE: Within NEMA MGI-22.40 definition when operating at full load.

COOLING: Centrifugal blower, direct connected.

RADIO INTERFERENCE LEVEL: Exceeds requirements for most marine radio-telephone equipment and standard AM televisions.

ARMATURE: Balanced laminated steel, double-dipped and baked.

ELECTRICAL CHARACTERISTICS					RATINGS		DERATINGS		ENGINE	
Model	Volts	Amps	Hertz	Phase	Wire Factor	Power KW			RPM	Start
15-614*	120/240	124/62	60	1	4	1.0	15	1% for each 10°F	1800	Remote
12-514*	220	60	50	1	4	1.0	12	(5°C) above 85°F (30°C)	1500	Remote

*Reconnectable to 120 volts @ 60 Hz or 110 volts @ 50 Hz @ twice the amperage.

ENGINE

- Engine type 4 cylinder, 4 cycle
- Displacement 90.9 C.I.D.
- Compression ratio 9.2:1
- Fuel Gasoline
- Block Cast iron
- Valve system Operated by overhead cam shaft-chain driven
- Main bearings Five
- Carburetor Down draft type with U.S.C.G. approved flame arrestor
- Governor Hoof, flyball type, 5% speed regulation
- Ignition system Horizontal electronic distributor driven by overhead cam. Reduces height and eliminates service points. Ignition system R.F.I. suppressed
- Weight 560 lbs
- Starting motor 12 volt negative ground
- Battery charging alternator 51 amps

STANDARD EQUIPMENT

- Brushless Generator • Overspeed Shutdown • High Water Temperature Shutdown • Low Oil Pressure Shutdown • Light weight Mounting Rails • Vibration Isolator Mounts • High Exhaust Temperature Shutdown • Flexible Fuel Supply Line • Lifting Eyes • Belt Guard • Fresh Water Cooled Exhaust Manifold • Raw Water Pump • 51 Amp Alternator (Ignition Protected) • Hoof Speed Governor • Down Draft Carburetor • Flame Arrestor (USCG Approved) • RFI Reduction (Ignition Shielding) • Water Injected Exhaust Elbow • Fresh Water Coolant Recovery Tank • Lube Oil Drain Hose • Operator's Manual • Unit Mounted Control Panel includes On-Start and Stop Switches, Engine Hour-Meter and Remote Terminal Connections

OPTIONAL EQUIPMENT

- Remote Control Panel • 15' Connector for Remote Panel • Ship/Shore Transfer Switch • Electronic Voltage Regulator • Hydro Hush Exhaust Silencer • Remote Engine Instruments • Parts Catalog • Instruction Manual

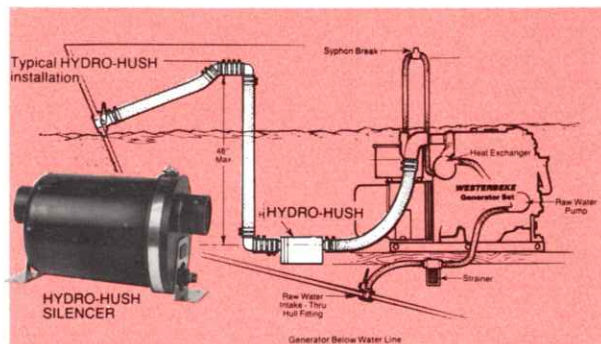

Call your Westerbeke representative or contact the Westerbeke Corporation

