

# WESTERBEKE 15.0 BTD - GENERATOR SOUND GUARD

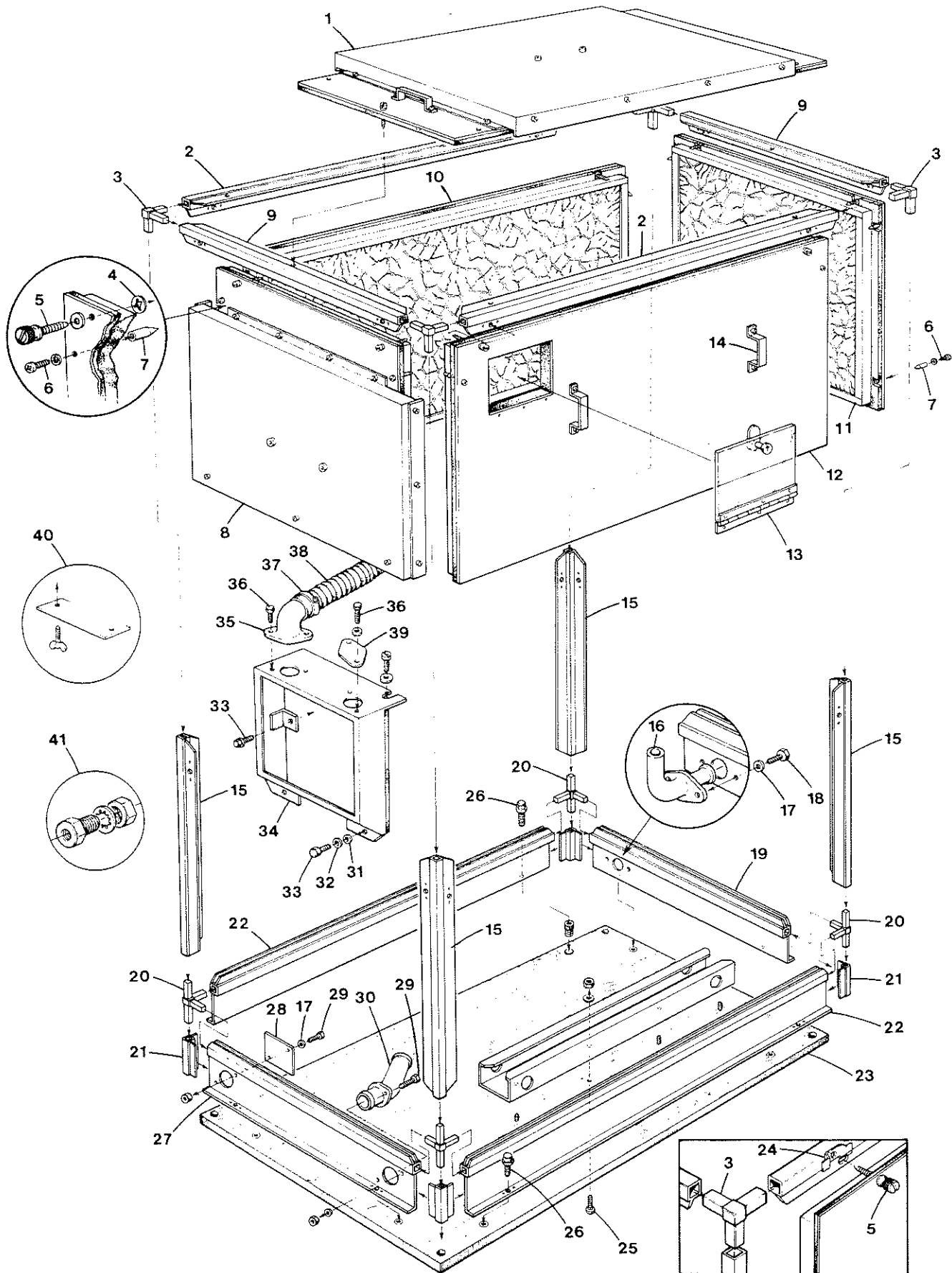

WESTERBEKE 15.0 BTD - GENERATOR SOUND GUARD

REF	PN	NAME	REMARKS	QUAN
1		PANEL	TOP	1
2	036676	RAIL	SIDE	2
3	024057	CORNER		4
4	030896	RETAINER	QUICK OPENING SCREW	AR
5	030895	SCREW	QUICK OPENING	AR
6	031940	SCREW	6-32 X 3/8 SEMS PHIL HD	AR
7	030775	GUIDE	PANEL ALIGNMENT	AR
8		PANEL	REAR	1
9	036678	RAIL	END	2
10		PANEL	SIDE	1
11		PANEL	FRONT	1
12		PANEL	SIDE WITH WINDOW	1
13	037417	WINDOW	ASSEMBLY	1
14-1	035720	HANDLE		AR
14-2	031937	SCREW	8-32 X 3/8 SEMS PHIL HD	AR
15	037392	POST	CORNER	4
16	036624	ELBOW	SEA WATER INLET	1
17	031752	LOCKWASHER	1/4	AR
18	031502	CAPSCREW	1/4NC X 5/8	2
19	036674	SKIRT	FRONT	1
20	024058	CORNER		4
21	030880	CLOSURE	SKIRT CORNER	4
22	036675	SKIRT	SIDE	2
23		BASE		1
24-1	030897	RECEPTACLE	QUICK OPENING SCREW	AR
24-2	030898	RIVET		AR
25	015683	BOLT	CARRIAGE 3/8NC X 1	6
26	031526	CAPSCREW	1/4NF	8
27	037389	SKIRT	REAR	1
28	037388	COVER	UNUSED EXHAUST PORT	1
29	031503	CAPSCREW	1/4NC X 3/4	4
30	036744	ELBOW	EXHAUST	1
31	031784	WASHER	M 6 DIN 125	4
32	031783	LOCKWASHER	M 6 DIN 127	4
33	017012	CAPSCREW	M 6 X 16 DIN 933	4
34	036669	PLENUM	AIR INTAKE	1
35	032590	ELBOW	AIR DUCT	1
36	031937	SCREW	8-32 X 3/8 SEMS PHIL HD	4
37	022559	CLAMP	HOSE 40	2
38	031902	HOSE	AIR INTAKE INCHES REQUIRED	21
39	036672	COVER	UNUSED AIR DUCT HOLE	1
40	037298	COVER KIT	BOTTOM OF GENSET VENT	1
41	023991	ADAPTER	FUEL LINES THRU SKIRT	2