

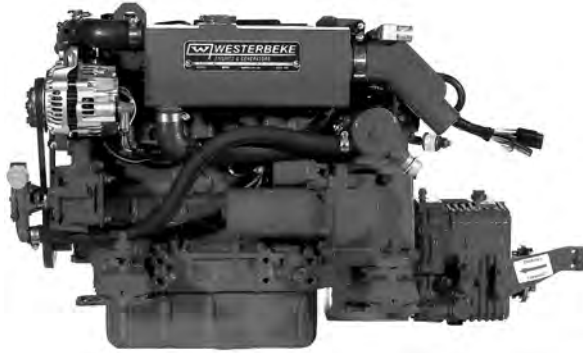

Long lasting, 3000-rpm performance...



44B Four Marine Diesel Engine



44B Four Marine Diesel Engine

Quiet and Compact

Designed by Westerbeke, pioneers in lightweight marine diesel engines, the 44B Four offers 4-cylinder, 4-cycle smoothness in a lightweight, compact engine. Designed to fit in the smallest engine compartments and reduce weight to the vessel, the 44B Four weighs only 416 pounds (188.7 kilos)! A tuned air intake silencer and 4-point vibration mounts also diminish sound and vibration for a smooth, quiet ride.

Powerful and Reliable

The naturally aspirated 1.76 liter design of the 44B Four provides instant power as well as simplicity and reliability. The 44B Four is rated at a low 3000-rpm for longer engine life and delivers dependable power without sacrificing smooth, quiet operation. For enhanced quiet performance, the 44B Four also has a tuned air intake silencer.

Easy Operation and Maintenance

In order to minimize engine maintenance, a fresh water-cooling system and self-bleeding fuel system are designed into the 44B Four. Some benefits are a standard front-mounted, raw water pump as well as a positive flow, hot water heater connection in the thermostat bypass circuit also located on the front of the engine for easy access.

The Name You Can Trust

The presence of Westerbeke in over 65 countries around the world provides customers with easy access to parts, service and technical support worldwide. Established in 1937, Westerbeke is committed to providing its customers with quality products and unequalled after sales support.

Standard Features

- Engine pre-wired to plug-in connector
- Circuit breaker protected electrical system
- Self-bleeding fuel system
- Front mounted, gear-driven raw water pump
- Fresh water cooled engine
- 12 volt, 50 amp alternator
- Domestic hot water connection
- Coolant recovery tank
- Throttle, stop, and shift control brackets
- Low oil pressure and high water temperature alarms
- Short profile marine gear with 2:1 reduction
- Glow plug cold starting aid
- Engine matched four-point, fail-safe, adjustable mounts
- Lube oil drain hose
- Tuned air intake silencer with filter
- Operators' manual and parts list
- EPA, CARB & CE compliant



Optional Admiral Panel

Admiral Panel Dimensions

Length	9.75" (247.7 mm)
Depth	4.0" (101.6 mm)
Height	6.0" (152.4 mm)

Performance Data

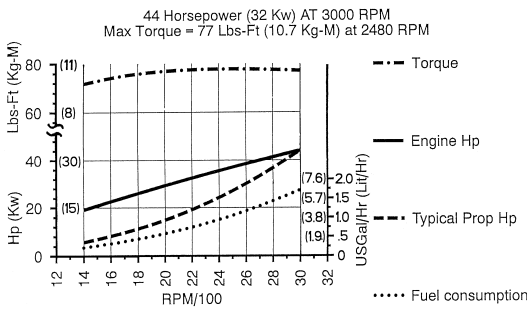

Westerbeke recommends a propeller that will allow the engine to turn 3000 RPM underway at full throttle

Construction – Engine Component

Cylinder head	Cast Iron
Cylinder block	Cast Iron
Crankshaft	Forged crankshaft, five main bearings
Valves	Overhead valves, rotating type
Fuel System	Self-bleeding
Intake system	Tuned intake silencer for maximum noise reduction
Cooling system	Fresh water-cooled with tube and shell type heat exchanger
Exhaust manifold	Cast aluminum, fresh water-cooled with built-in expansion tank

Specifications

Number of cylinders	4 Cylinder, vertical in-line
Cycles	4 cycle
Displacement	107.27 cu. in. (1.758 liter)
Bore and stroke	3.07" x 3.62" (78 mm x 92 mm)
Compression ratio	22:1
Maximum angle of installation	Not to exceed 14° in all directions
Maximum angle of operation	Not to exceed 30° for 30 min.
Crankshaft direction of rotation	Counterclockwise as viewed from flywheel end
Propeller shaft dir. of rotation	Right hand - Std. transmission
Dry weight	416 lbs. (188.7 kilos)
Combustion system	Swirl type
Aspiration	Naturally aspirated
Lubrication system	Forced lubrication by gear pump
Cooling system capacity	7 quarts (6.6 liters)
Starting aid	12 volt sheathed type glow plug
Engine stop	Manual type
Fuel injection pump	Bosch type
Governor	Centrifugal type
Injectors	Throttle type
Fuel Filter	Primary
Lube oil filter	Full flow, spin-on element
Lubricant capacity	6.3 quarts (6.0 liters)
Fuel transfer pump	Electrical
Fuel supply and return piping	1/4" ID (6.35 mm) minimum 3/8" ID (9.53 mm) maximum
Starting motor	12 volt, solenoid actuated
Battery charging Alternator	50 ampere (12 Volts)
Cold cranking amps	160 at 79 degrees F
Alternator/regulator	Automatic, solid state built-in
Electrical system	12 volts DC, negative ground

Standard Equipment

Standard gear ratio	2:1
Mounting centers	14.6", 16.0" & 18.5"
Flexible Mounts	Adjustable fail-safe rubber type
Starting aid	
Domestic hot water connection	
Coolant recovery tank	
Battery charging alternator	50 amp
Control brackets	For all control attachments
Pre-wired engine	
Gear-driven raw water pump	
Lube oil drain hose	
Gear oil cooler	
Oil fill	Top and service side
Air filter	
Circuit breaker protected electrical system	
Operators' manual and parts list	

Optional Equipment

Captain panel with alarm (tachometer with lights)	
Admiral panel with alarms (tachometer with gauges)	
Dual station senders	
Other gear ratios	Consult local distributor
Hydraulic transmissions	Consult local distributor
Remote expansion tank	
72 or 90 amp alternator in place of standard	
Muffler and fittings	
"A" on board spare parts kit	
"B" extended cruising spare parts kit	
Anti-siphon valve for overboard cooling discharge water	
45 degree water injected exhaust elbow	
Propeller shaft couplings (rigid/flexible) available standard sizes	

Dimensions Inches (millimeters)

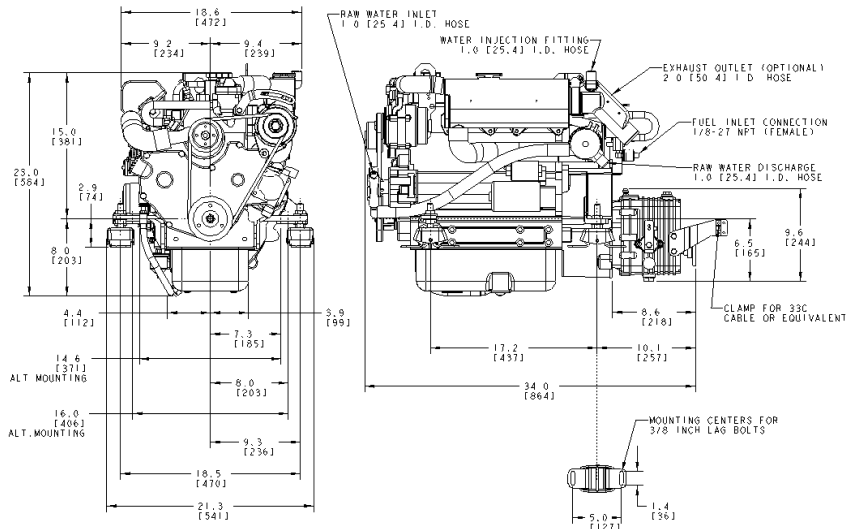

Authorized Dealer