

# A new, quiet, smooth running marine power-plant from Westerbeke

A small, reliable, smooth running Generator Set for all your shipboard needs; electrical power at the turn of a switch for: Air Conditioning, Electric Cooking, Microwave Oven, Refrigeration, Cabin Appliances, Power Tools, and Navigation/Communication Equipment. Like all Westerbeke Generator Sets, it is fresh water cooled with an Engine mounted Heat Exchanger. The Engine and Generator are connected through special Drive Discs, Flywheel and Flywheel Housing into a compact carefully aligned Generator Set. The complete unit is mounted on lightweight rails through soft flexible

Isolator Mounts that prevent the transfer of vibration. A lightweight removable Drip Tray is fitted under the unit between the mounting rails. The generator components meet the safety regulations of U.S. Coast Guard 33 CFR-183.

The Westerbeke 8 is lightweight, safe, dependable, durable, and economical to operate. Designed to operate at a quiet 1800 RPM, the Westerbeke 8 offers 4 cylinder, 4 cycle smoothness to provide electrical conveniences usually found only on large boats.

## WESTERBEKE 8KW GASOLINE MARINE ENGINE GENERATOR SET

- SMOOTH AND QUIET FOUR CYLINDER PERFORMANCE
- ENCLOSED FRESH WATER COOLING
- AUTOMATIC SAFETY SHUT-DOWNS
- SIMPLE ENGINE AND GENERATOR CONTROLS FOR RELIABILITY

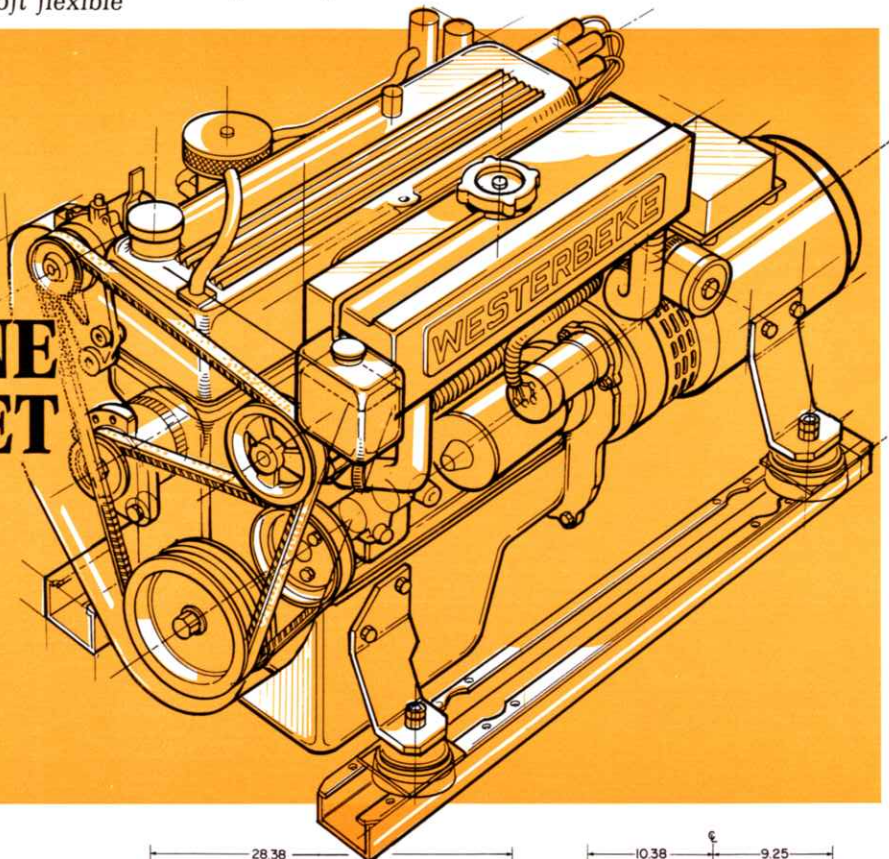

### STANDARD EQUIPMENT

- Overspeed Shutdown
- High Water Temperature Shutdown
- Low Oil Pressure Shutdown
- Lightweight Mounting Rails
- Vibration Isolator Mounts
- High Exhaust Temperature Shutdown
- Flexible Fuel Supply Line
- Lifting Eyes
- Belt Guard
- Fresh Water Cooled Exhaust Manifold
- Raw Water Pump
- 51 Amp Alternator (Ignition Protected)
- Hoof Speed Governor
- Down Draft Carburetor
- Flame Arrestor (USCG Approved)
- RFI Reduction (Ignition Shielding)
- Water Injected Elbow
- Fresh Water Coolant Recovery Tank
- Lube Oil Drain Hose

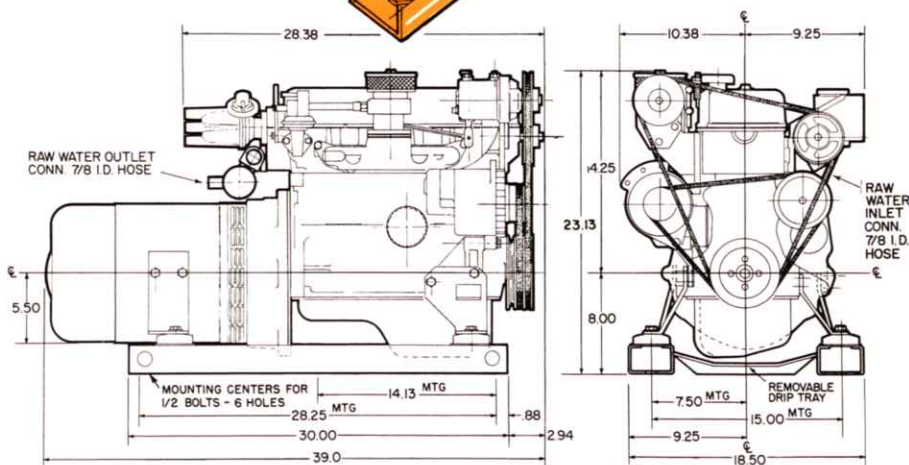

### OPTIONAL EQUIPMENT

- Remote Control Panel
- 15' Connector for Remote Panel
- Ship/Shore Transfer Switch
- Hydro-Hush B (water lift silencer)
- Remote Engine Instruments



Hydro-Hush B (water lift silencer)



**GASOLINE GENERATORS: 6.5kw • 8kw • 11kw**

Fresh Water Cooled Diesel and Gasoline Generators from Westerbeke

