

# 5.0 BCDA/B & 7.6 BTD SOUND GUARD INSTALLATION

## INTRODUCTION

The 5.0 BCDA, 5.0 BCDB and 7.6 BTD SOUND GUARDS utilize the large capacity fan between the flywheel and generator to supply cooling air, combustion air and evacuation air. The installation must be well planned so that there is free circulation of air around the SOUND GUARD. The front duct and the intake grill must be at least six inches from any obstruction outside the SOUND GUARD.

## PREPARING THE GENERATOR FOR THE SOUND GUARD

1. Uncrate the SOUND GUARD and locate the base assembly, 2 side panels, front and rear panels, top panel, air intake plenum, rails, posts, corner pieces, and bag with assorted hardware and other items needed for constructing your SOUND GUARD.
2. Uncrate the generator and discard the louvered cover on the back of the generator. Save the screws which held it on.
3. Replace the louvered cover with the air intake plenum from the SOUND GUARD kit as illustrated. Use care when tightening the metric 6 x 15mm screws and washers supplied. As they are being screwed into an aluminum casting, over-tightening may strip the threads.
4. Install the two closures into the two rectangular holes cast in the bottom of the generator stator housing. Due to irregularity in the casting, some clips may require light bending in or out to fit snugly. These closures are necessary to prevent recirculation of hot air within the Sound Guard enclosure.
5. Mount the air exhaust plenum on the inside of the front panel using the four screws provided. Insert the guide pins in the front panel after assembling the air exhaust plenum and the front panel.

**NOTE:** The next operation is most easily done in the shop by hoisting the generator set to a comfortable working height for good visibility.

## INSTALLING THE GENERATOR IN THE SOUND GUARD

6. Set the generator on the SOUND GUARD plywood base assembly so that the bolts in the base align with the corresponding holes in the generator set rails. The generator end (with the air intake plenum attached) goes toward the rear skirt. There should be very little space between the air intake plenum and the rear skirt. When the generator is set into position, tighten the four nuts.

**NOTE:** The air intake plenum should almost touch the rear skirt. This helps ensure the consistent flow of cool intake air to the generator.

7. Cut holes in the skirt for the fuel, battery and power connections, ensuring that they are positioned convenient to the installation of the generator. Use the supplied bushings to prevent the connections from unnecessary wear and tear.

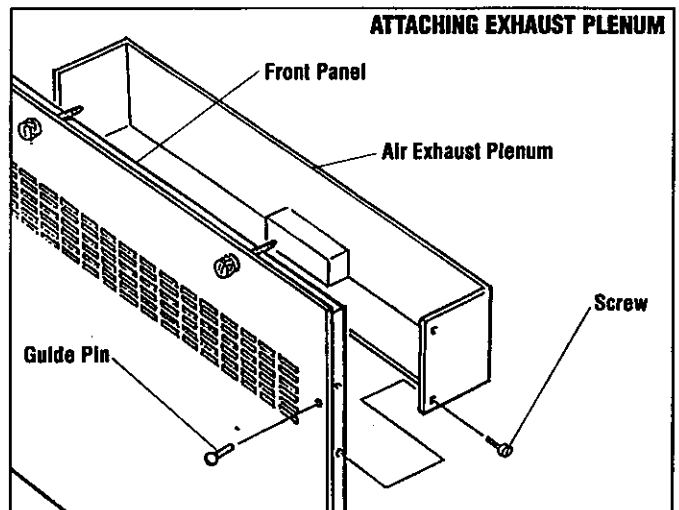
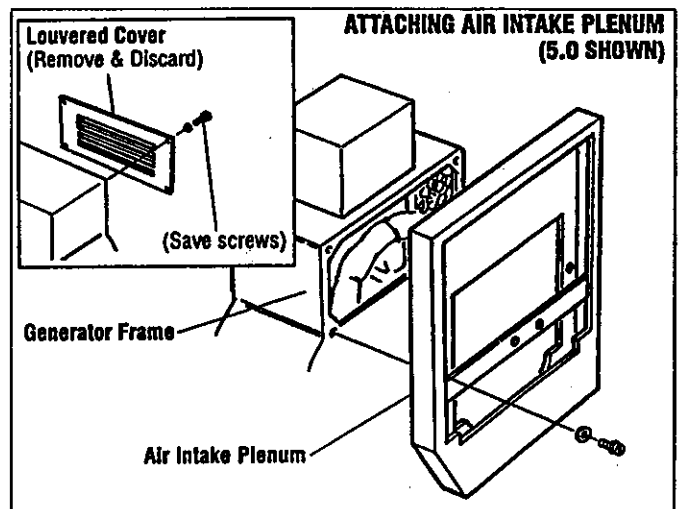
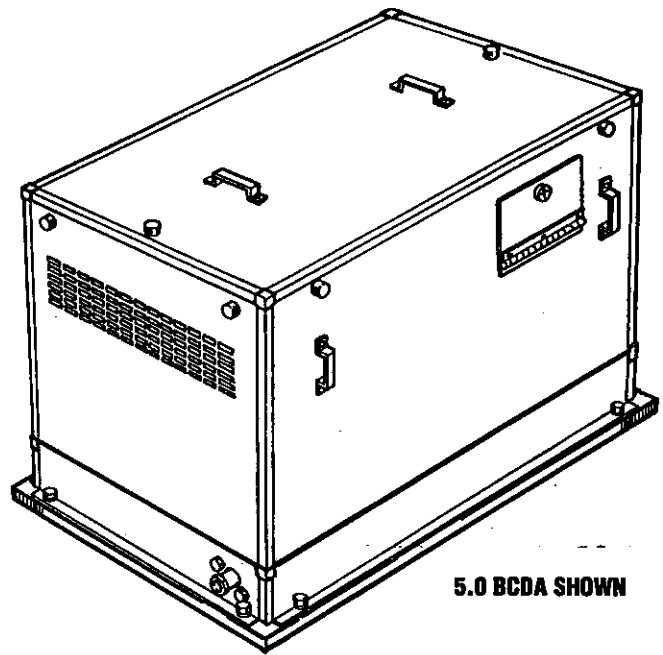

## 5.0 BCDA/B & 7.6 BTD SOUND GUARD INSTALLATION

Water and exhaust holes are pre-drilled through the front and rear skirts, and the appropriate fittings and hoses are provided.

**NOTE:** Drilling the access holes for fuel, battery and power leads in SOUND GUARD with skirts removed from the base is much easier than attempting the operation with the skirts in place.

8. The exhaust hose is wire-inserted and, as such, may be difficult to push onto the exhaust fittings. Lubricating the inside of the exhaust hose ends (approximately two inches) will make this easier to do.
9. After all the service connections have been made, replace the skirts and assemble the frame components using the illustration as a guide.

At this point the front engine pulley screws should clear the front panel foam by 1/16 to 1/8 of an inch. The rear panel foam should press against the air intake plenum to make a tight seal preventing the recirculation of air. If this joint is open more than 1/8 of an inch, add a strip of the 3/4 inch foam gasket material (supplied) to the rear edges of the plenum.

10. The elbow at the top of the raw water pump must be turned approximately eighty degrees to prevent the hose from rubbing against the side panel of the SOUND GUARD. The raw water elbow at the exhaust should point straight down and the raw water hose connects forward to the heat exchanger.
11. The panels (side, top, front and rear) are fastened to the corner posts and rails with knurled quick release screws.

**NOTE:** Care should be taken to not over-tighten these screws as they are being screwed into aluminum, and over-tightening may strip the threads.

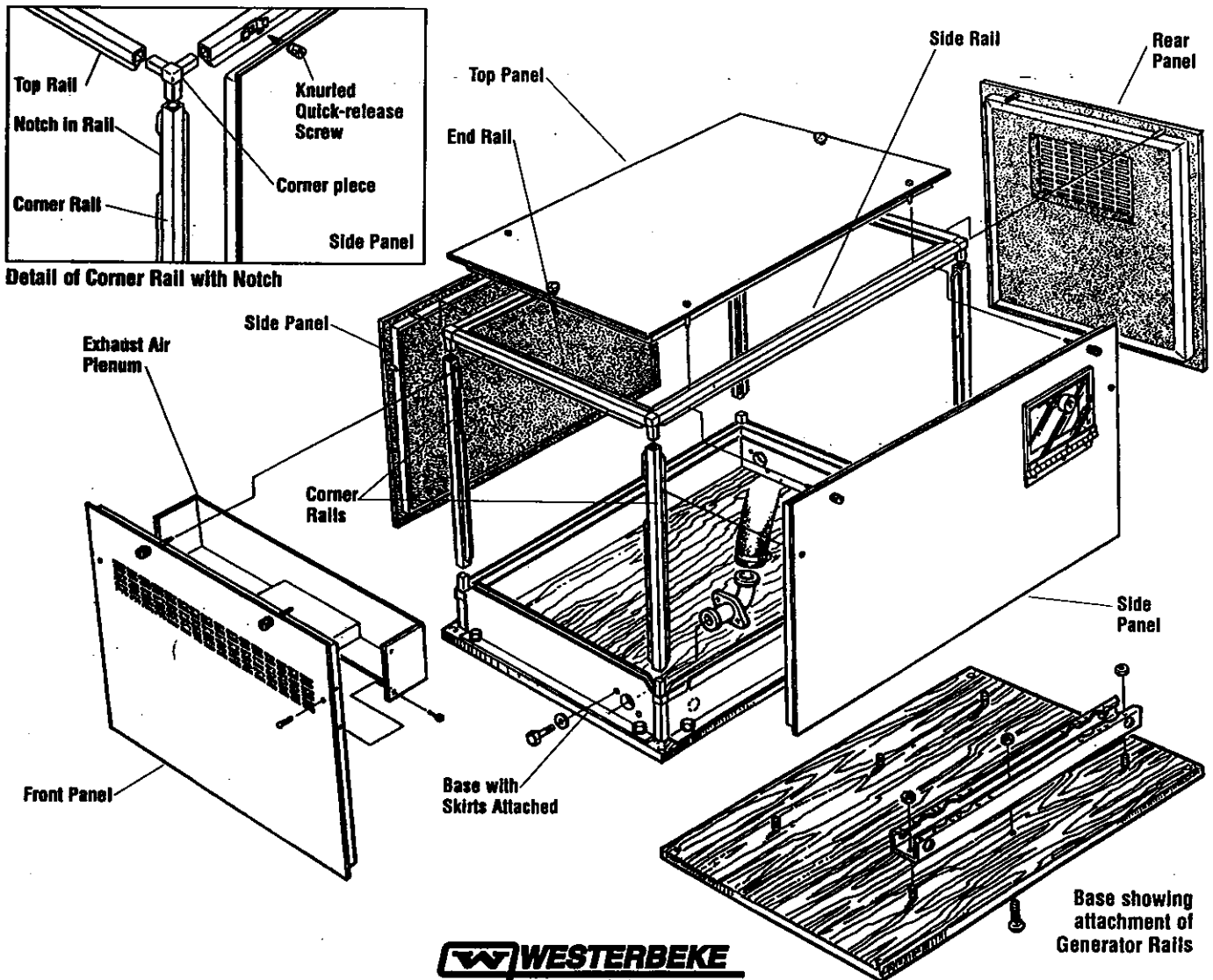

# 8.0 BTD & 10.0 BTD SOUND GUARD INSTALLATION

## INTRODUCTION

The 8.0 BTD and 10.0 BTD SOUND GUARDs utilize the large capacity fan between the flywheel and generator to supply cooling air, combustion air and evacuation air. The installation must be well planned so that there is free circulation of air around the SOUND GUARD. The front duct and the intake grill must be at least six inches from any obstruction outside the SOUND GUARD.

## PREPARING THE GENERATOR FOR THE SOUND GUARD

1. Uncrate the SOUND GUARD and locate the base assembly, 2 side panels, front and rear panels, top panel, air intake plenum, rails, posts, corner pieces, and bag with assorted hardware and other items needed for constructing your SOUND GUARD.
2. Uncrate the generator and discard the protective cover on the back of the generator. Save the screws which held it on.
3. Replace the protective cover with the air intake plenum from the SOUND GUARD kit as illustrated. Use care when tightening the metric 6 x 15mm screws and washers supplied. As they are being screwed into an aluminum casting, over-tightening may strip the threads.
4. Install the two closures into the two rectangular holes cast in the bottom of the generator stator housing. Due to irregularity in the casting, some clips may require light bending in or out to fit snugly. These closures are necessary to prevent recirculation of hot air within the Sound Guard enclosure.
5. **8.0 Only:** Mount the air exhaust plenum on the front panel using the six screws provided. Insert the guide pins in the front panel after assembling the air exhaust plenum and the front panel.

**NOTE:** This operation is most easily done in the shop by hoisting the generator set to a comfortable working height for good visibility.

## INSTALLING THE GENERATOR IN THE SOUND GUARD

6. Set the generator on the SOUND GUARD plywood base assembly so that the bolts in the base align with the corresponding holes in the generator set rails. The generator end (with the air intake plenum attached) goes toward the rear skirt. When the generator is set into position, tighten the four nuts.
7. Cut holes in the skirt for the fuel, battery and power connections, ensuring that they are positioned convenient to the installation of the generator. Use the supplied bushings to prevent the connections from unnecessary wear and tear. Water and exhaust holes are pre-drilled through the front and rear skirts, and the appropriate fittings and hoses are provided.

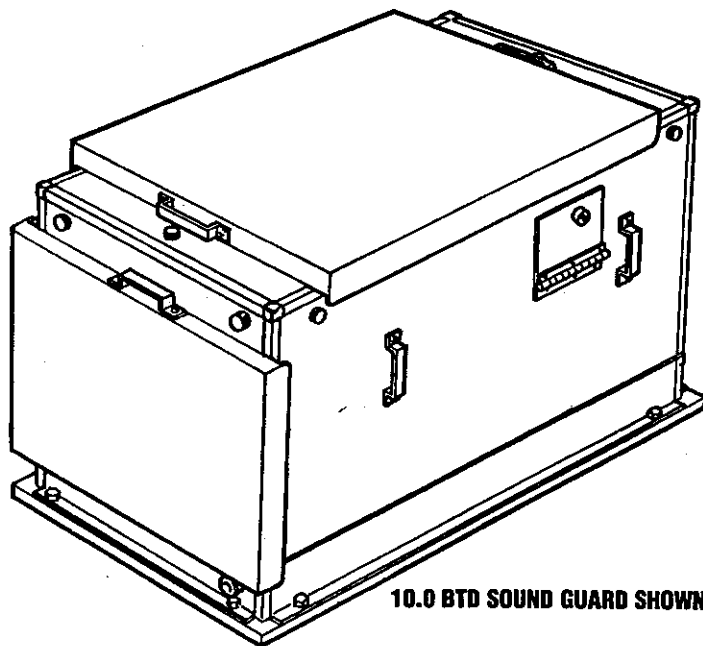

10.0 BTD SOUND GUARD SHOWN

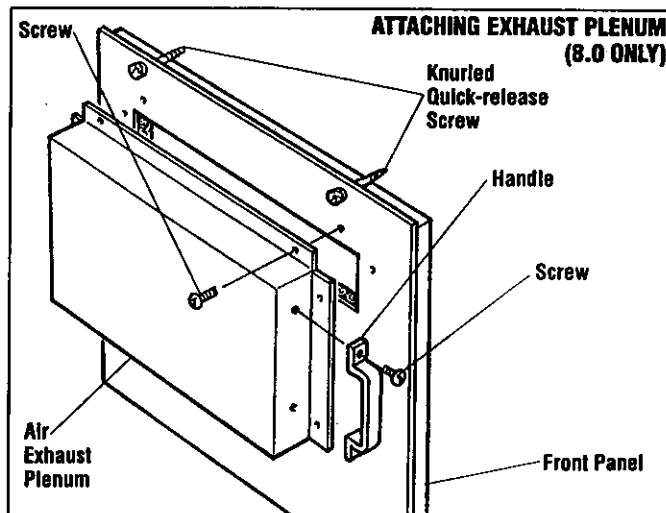
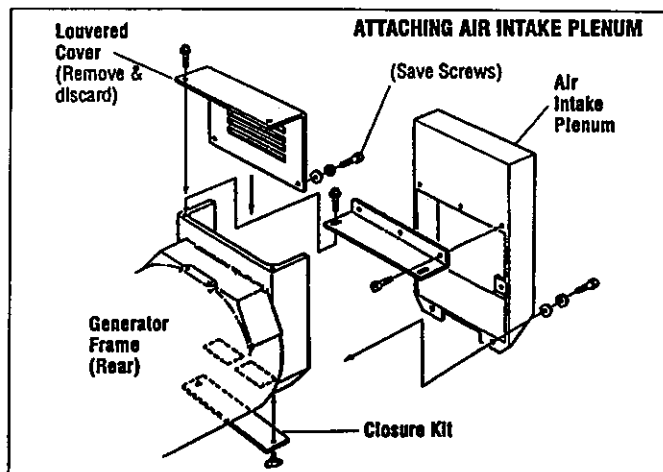

## 8.0 BTD & 10.0 BTD SOUND GUARD INSTALLATION

**NOTE:** Drilling the access holes for fuel, battery and power leads in **SOUND GUARD** with skirts removed from the base is much easier than attempting the operation with the skirts in place.

8. The exhaust hose is wire-inserted and, as such, may be difficult to push onto the exhaust fittings. Lubricating the inside of the exhaust hose ends (approximately two inches) will make this easier to do.
9. After all the service connections have been made, replace the skirts and assemble the frame components using the illustration below as a guide.

At this point the front engine pulley screws should clear the front panel foam by 1/16 to 1/8 of an inch. The rear panel foam should press against the air intake plenum to make a tight seal preventing the recirculation of air. If this joint is open more than 1/8 of an inch, add a strip of the 3/4 inch foam gasket material (supplied) to the rear edges of the plenum.

10. The elbow at the top of the raw water pump must be turned approximately eighty degrees to prevent the hose from rubbing against the side panel of the **SOUND GUARD**. The raw water elbow at the exhaust should point straight down and the raw water hose connects forward to the heat exchanger.
11. The panels (side, top, front and rear) are fastened to the corner posts and rails with knurled quick release screws. Care should be taken to not over-tighten these screws.

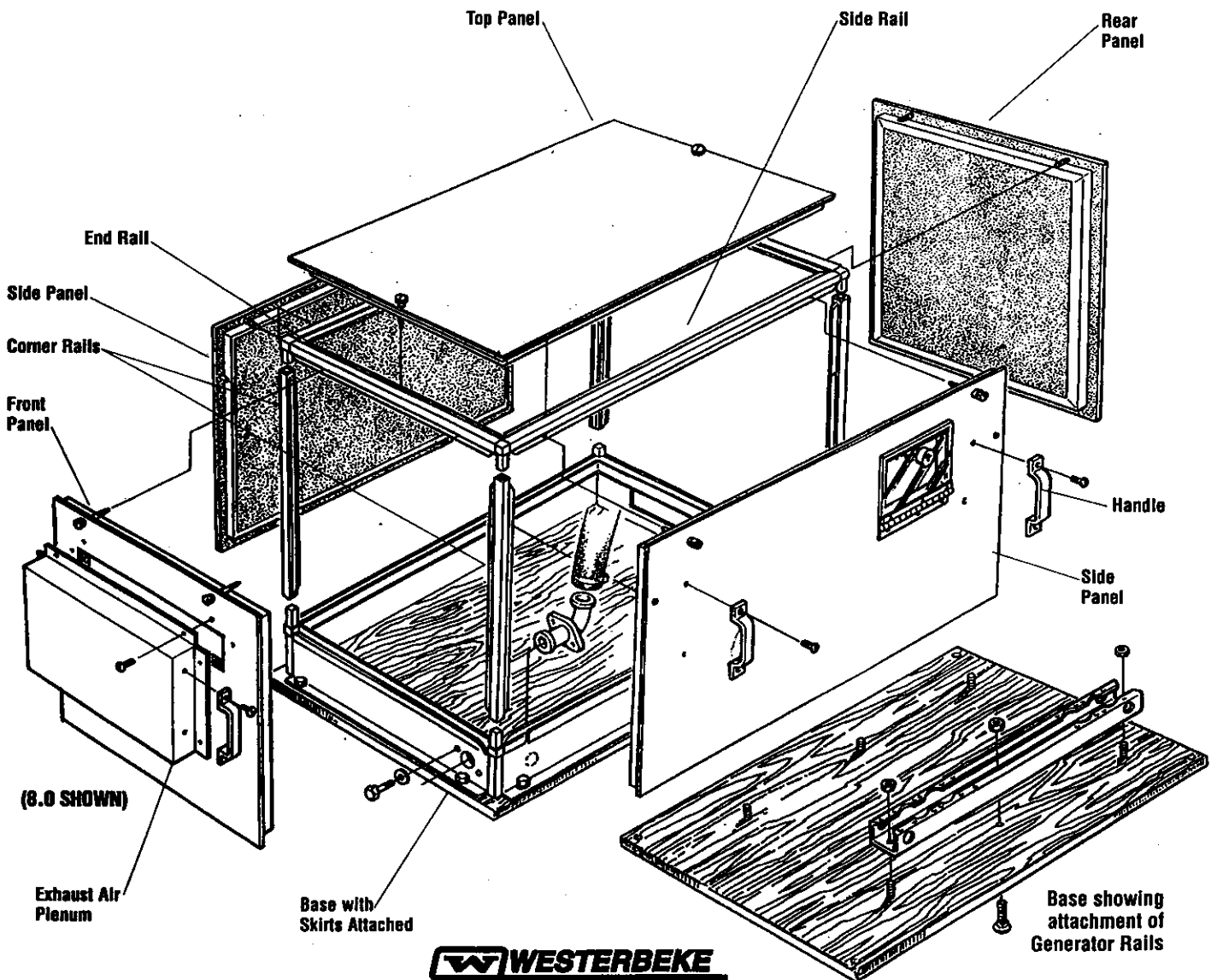
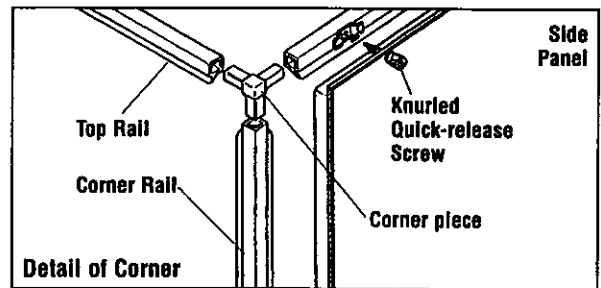

**WESTERBEKE**  
Engines & Generators

# 11.0 BTD, 12.5 BTDA & 15.0 BTDB SOUND GUARD INSTALLATION

## INTRODUCTION

The 11.0 and 12.5 BTDA and 15.0 BTDB SOUND GUARDS utilize the large capacity fan between the flywheel and generator to supply cooling air, combustion air and evacuation air. The installation must be well planned so that there is free circulation of air around the SOUND GUARD. The front duct and the intake grill must be at least six inches from any obstruction outside the SOUND GUARD.

## PREPARING THE GENERATOR FOR THE SOUND GUARD

1. Uncrate the SOUND GUARD and locate the base assembly, 2 side panels, front and rear panels, top panel, air intake plenum, rails, posts, corner pieces, and bag with assorted hardware and other items needed for constructing your SOUND GUARD.
2. Attach the Air Exhaust Plenum to the Front Panel as illustrated using the supplied screws.
3. Uncrate the generator and discard the louvered cover on the back of the generator. Save the screws which held it on.
4. Replace the louvered cover with the air intake plenum from the SOUND GUARD kit. Use care when tightening the metric 6 x 15mm screws and washers supplied. As they are being screwed into an aluminum casting, over-tightening may strip the threads.
5. Install the closure kit to cover the two rectangular holes cast in the bottom of the generator frame. These closures are necessary to prevent recirculation of hot air within the Sound Guard enclosure.
6. Attach the handles to the top and side panels using the screws provided.
7. Mount the air exhaust plenum on the front panel using the four screws provided. Insert the guide pins in the front panel after assembling the air exhaust plenum and the front panel.

**NOTE:** The next operation is most easily done in the shop by hoisting the generator set to a comfortable working height for good visibility.

## INSTALLING THE GENERATOR IN THE SOUND GUARD

8. Set the generator on the SOUND GUARD plywood base assembly so that the bolts in the base align with the corresponding holes in the generator set rails. The generator end (with the air intake plenum attached) goes toward the rear skirt. There should be very little space between the air intake plenum and the rear skirt. When the generator is set into position, tighten the four nuts.

**NOTE:** The air intake plenum should almost touch the rear skirt. This helps ensure the consistent flow of cool intake air to the generator.

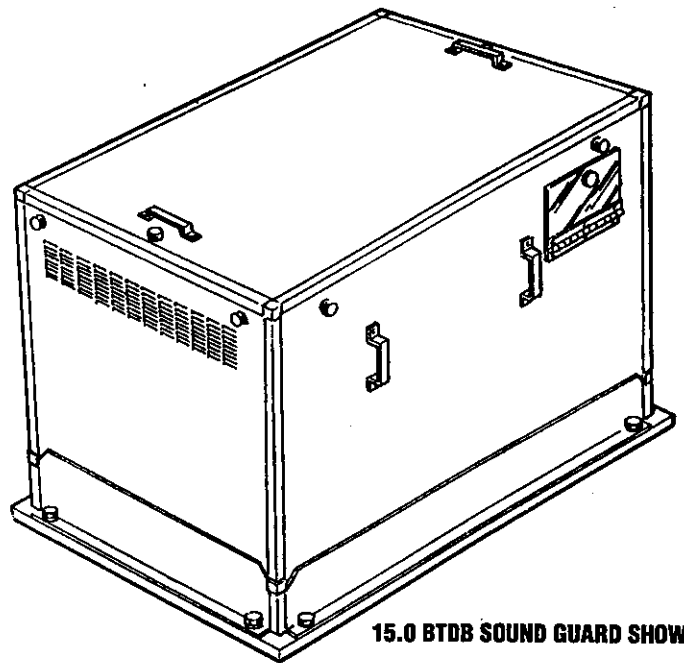

15.0 BTDB SOUND GUARD SHOWN

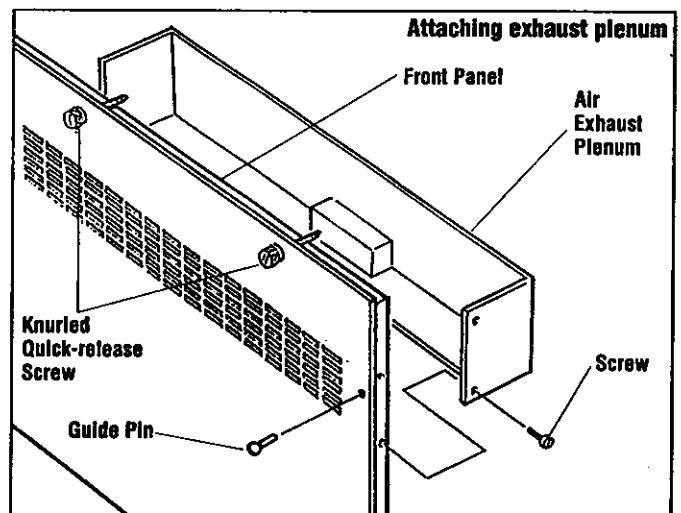
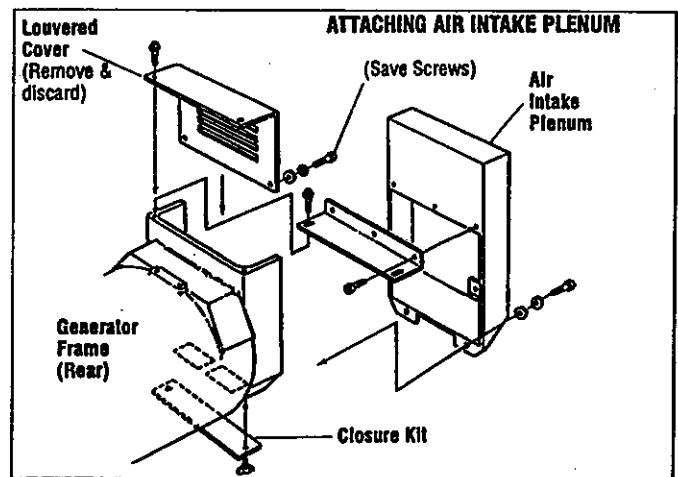

# 11.0 BTD, 12.5 BTDA & 15.0 BTDB SOUND GUARD INSTALLATION

9. Cut holes in the skirt for the fuel, battery and power connections, ensuring that they are positioned convenient to the installation of the generator. Use the supplied bushings to prevent the connections from unnecessary wear and tear. Water and exhaust holes are pre-drilled through the front and rear skirts, and the appropriate fittings and hoses are provided.

**NOTE:** Drilling the access holes for fuel, battery and power leads in SOUND GUARD with skirts removed from the base is much easier than attempting the operation with the skirts in place.

10. The exhaust hose is wire-inserted and, as such, may be difficult to push onto the exhaust fittings. Lubricating the inside of the exhaust hose ends (approximately two inches) will make this easier to do.

11. After all the service connections have been made, replace the skirts and assemble the frame components using the illustration as a guide.

**NOTE:** When assembling the frame, ensure that the notches in the corner posts face front as these notches facilitate the proper fit of the front panel with its attached plenum.

At this point the front engine pulley screws should clear the front panel foam by 1/16 to 1/8 of an inch. The rear panel foam should press against the air intake plenum to make a tight seal preventing the recirculation of air. If this joint is open more than 1/8 of an inch, add a strip of the 3/4 inch foam gasket material supplied to the rear edges of the plenum.

12. The elbow at the top of the raw water pump must be turned approximately eighty degrees to prevent the hose from rubbing against the side panel of the SOUND GUARD. The raw water elbow at the exhaust should point straight down and the raw water hose connects forward to the heat exchanger.

13. The panels (side, top, front and rear) are fastened to the corner posts and rails with knurled quick release screws.

**NOTE:** Care should be taken to not over-tighten these screws.

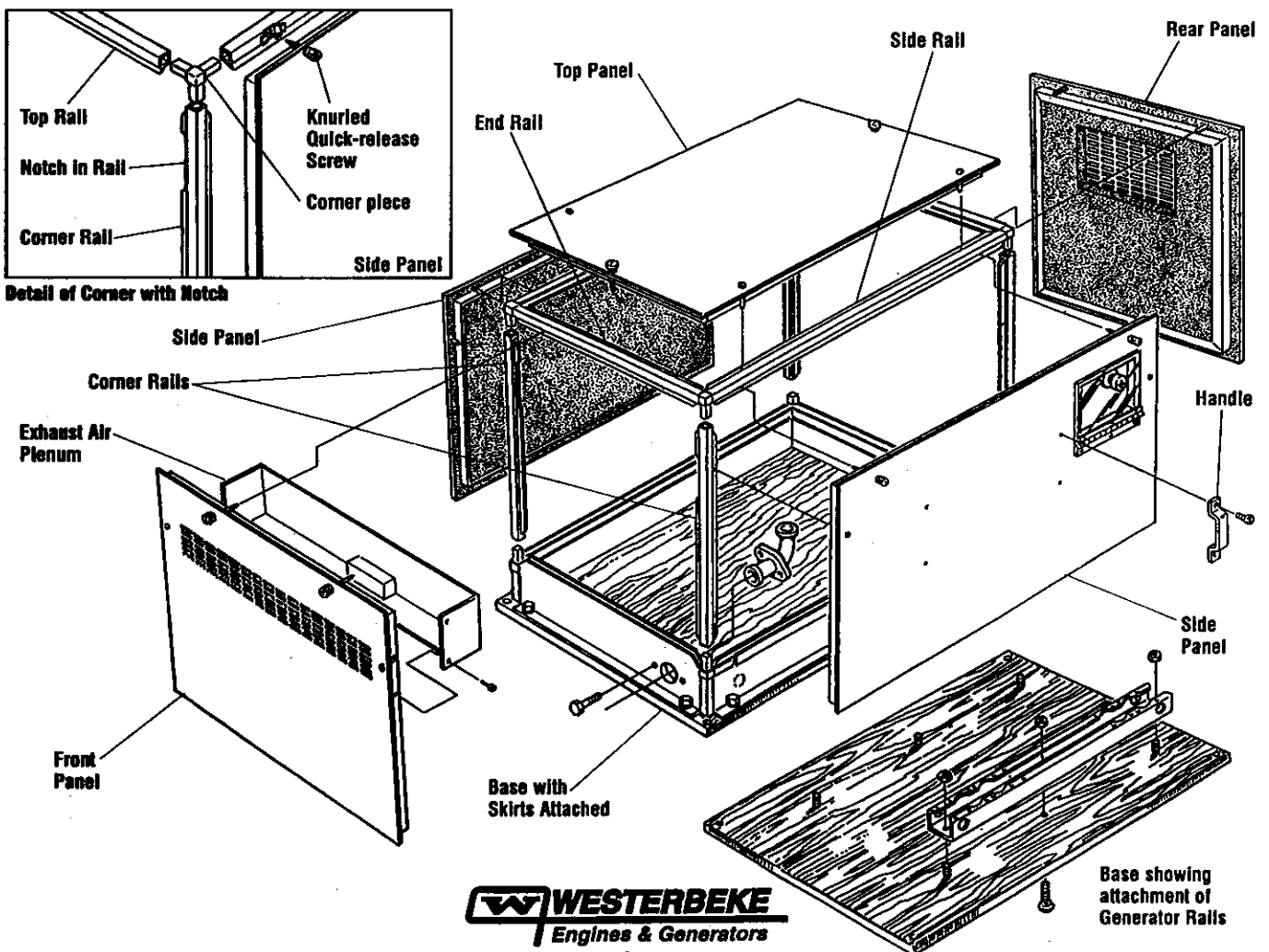

# 20 BEDA, 25 BED & 32 BEDA SOUND GUARD INSTALLATION

## INTRODUCTION

The 20, 25 and 32 BED(A) SOUND GUARD rests on a wooden base that is raised 2-1/2 inches above the deck. The generator receives air through an opening underneath the base at the generator end, and expels air through an opening at the front of the engine. All the connections to the generator (water, battery, fuel and instruments) can be led through these openings. The interior of the SOUND GUARD is divided by an air dam to prevent the recirculation of heated air, and a flex duct provides unheated combustion air to the air intake.

All panels are lined with sound absorbent material, which is mylar faced for cleanliness.

## REQUIREMENTS

The 20, 25 and 32 BED(A) SOUND GUARD requires a 28x50 inch level deck around the generator. The placement of this area with respect to the generator is defined by the distance from the generator mounting rails to the SOUND GUARD side rails and is as follows:

- a. 4-1/2 inches from the front of the engine rails to the front of the SOUND GUARD rails.
- b. 3-3/4 inches from the left engine rail (air intake side) to the outside of the left SOUND GUARD rail.
- c. 4-1/2 inches from the right engine rail (exhaust manifold side) to the outside of the right SOUND GUARD rail.

In order for the air dam to seal properly against the generator, the crankshaft height above the deck should be 10-1/4 inches. This dimension can be measured from the center of the crankshaft pulley and from the center of the generator end. The height of the generator can be adjusted by shimming the engine between the mounting feet and the isolators.

## PREPARATION OF THE GENERATOR

1. Install the generator and bolt the engine rails to the deck. Disconnect the exhaust hose.
2. Remove and discard the generator louvered panel cover and its two screws.

## ASSEMBLY OF THE SOUND GUARD BASE

**NOTE:** The SOUND GUARD base will move freely around the generator rails until the entire SOUND GUARD is assembled. At that point the base will be secured in its permanent position.

1. Cut a 12-1/2 inch length of the foam Lower Air Seal. Peel off the paper backing and attach the foam to the curve of the SOUND GUARD Support Rail so that the foam is centered on the curve and extending a small amount off either end.
2. Hoist the generator so that the SOUND GUARD base can slide underneath it. With the base in position, lower the generator so that the lower air seal fits against the large diameter surface of the generator.

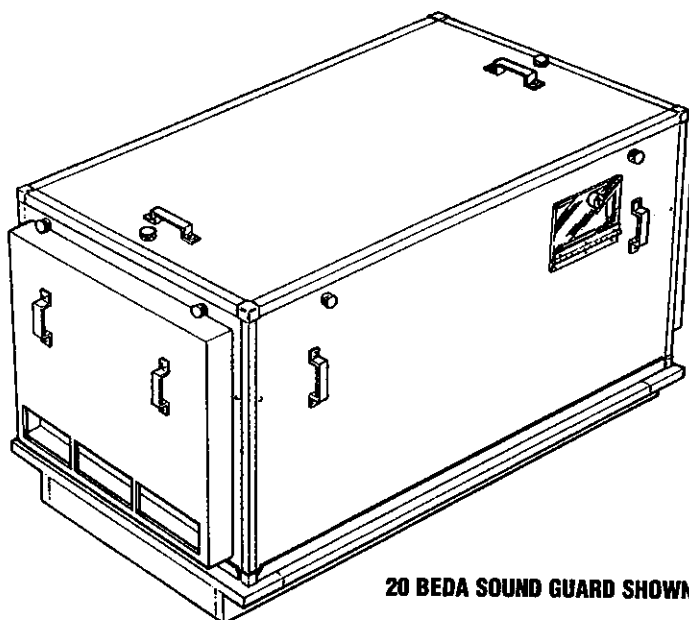

20 BEDA SOUND GUARD SHOWN

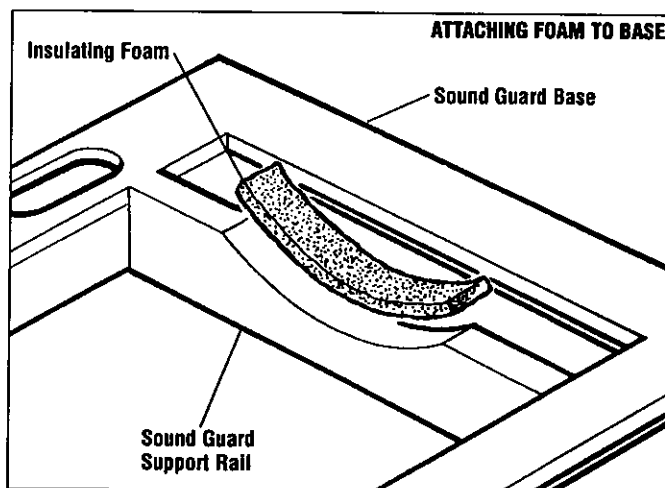
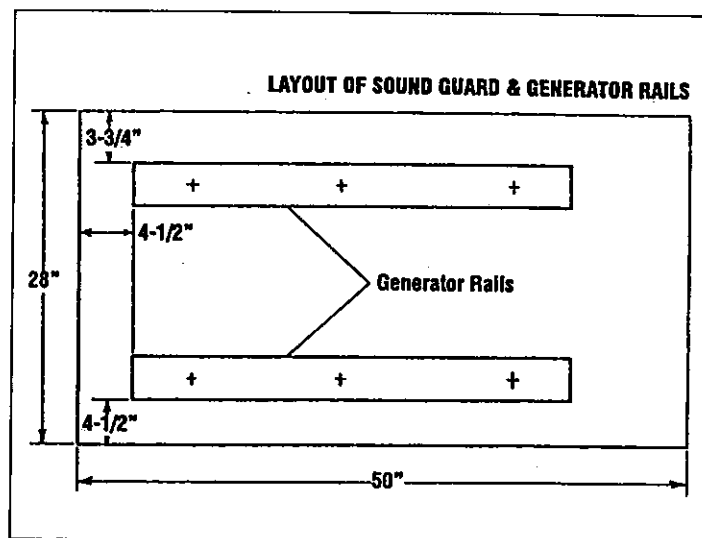

# 20 BEDA, 25 BED & 32 BEDA SOUND GUARD INSTALLATION

- Attach metal Side Extrusions to the Side Decks using two 1-3/4 inch 10-32 screws with flat washers and stop nuts.

**NOTE:** Ensure that the grooved edges of the extrusions face out.

- Slide both End Extrusions into place, using three Leg Extrusion Corners. Attach End Extrusions to the Front and Rear Decks using two 1-3/4 inch 10-32 screws with flat washers and stop nuts.
- Refer to the REQUIREMENTS section of this Installation Sheet and move the SOUND GUARD to its correct position with respect to the Engine Rails.

## ASSEMBLY OF THE SOUND GUARD

- Cut one 10-7/8 inch and two 18-1/4 inch lengths of the foam Upper Air Seal. Peel off the paper backing and attach the two longer pieces to the inner curved sides of the plastic Air Dam. Attach the shorter piece to the upper straight edge of the Air Dam.
- Place the Air Dam on the generator backend with the hollow side facing away from the engine. The foam seal on the Air Dam should meet snugly with the Lower Air Seal, as well as with the generator itself. Attach a 4 inch strip of Sticky-back Gasketing to the Air Dam where it contacts the upper edge of the Control Box of the generator. This will prevent contact and vibration between the Air Dam and the Control Box.
- Attach the lower corners of the Air Dam to the SOUND GUARD Side Decks using 1/2 inch #8 screws with flat washers.
- The Air Dam moulding includes two spuds for connecting a combustion air hose to the engine. The top spud is more convenient for the 20 KW generator and the lower spud is more convenient for the 25 KW generator, although either may be used. Cut off the end of the appropriate spud and connect the Flexible Hose between the Air Dam and the engine air intake manifold, cutting the Flexible Hose to the proper length. Attach the Flexible Hose with hose clamps. Do not over tighten the hose clamps.
- Check the foam seal between the Air Dam and the generator, and make sure the foam has not accidentally worked loose during the installation of the Air Dam.
- Attach the SOUND GUARD Panel Handles to each panel using the supplied 3/8 inch #8-32 sems screws.
- Assemble the SOUND GUARD frame using the Upper End and Side Extrusions, Corner Posts and 3-Leg Extrusion Corners.
- Place the Side, End and Top Panels onto the SOUND GUARD frame using the Guide Pins to align the Panels to the frame. Each panel attaches to the frame with knurled quick release screws. Care should be taken to not over-tighten these screws as they are being screwed into aluminum, and over-tightening may strip the threads.
- Check to see that the mylar lining is not in contact with any part of the engine, and then screw the SOUND GUARD base to the boat deck using eight 4 inch #14 screws.

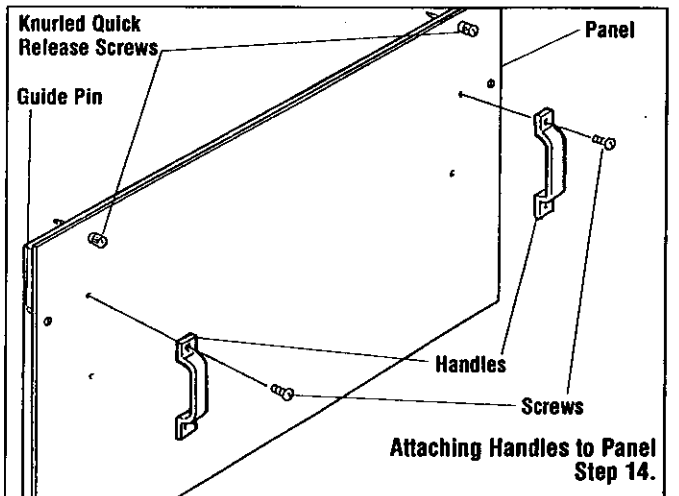
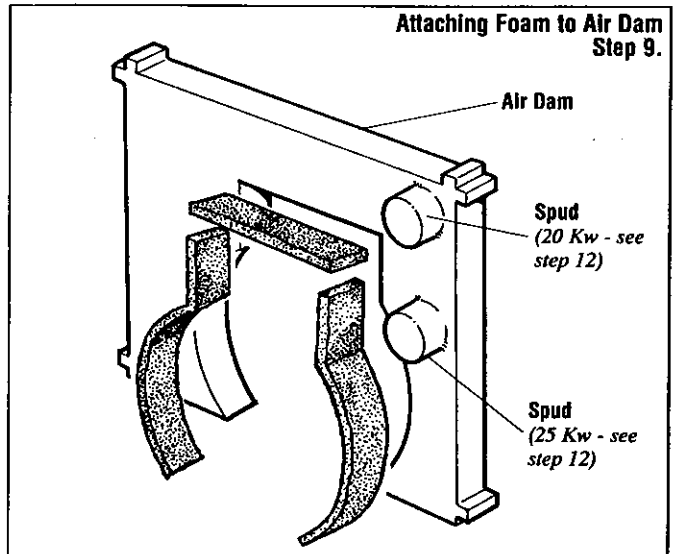
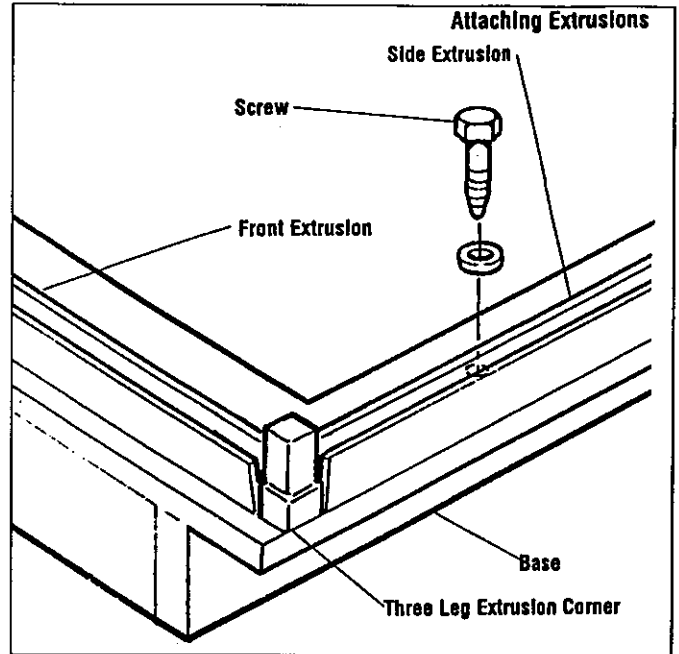

# 20 BEDA, 25 BED & 32 BEDA SOUND GUARD INSTALLATION

15. Run the exhaust hose through the port so the bend in the hose fills the port. Seal any remaining air space.

**NOTE:** WESTERBEKE suggests running all connections (water, battery, fuel and instruments) through the Air Inlet Duct. However, if it is more convenient, holes may be drilled through the wooden side decks inside the metal extrusions, or through the support rails of the SOUND GUARD. All holes should be sealed so they are airtight.

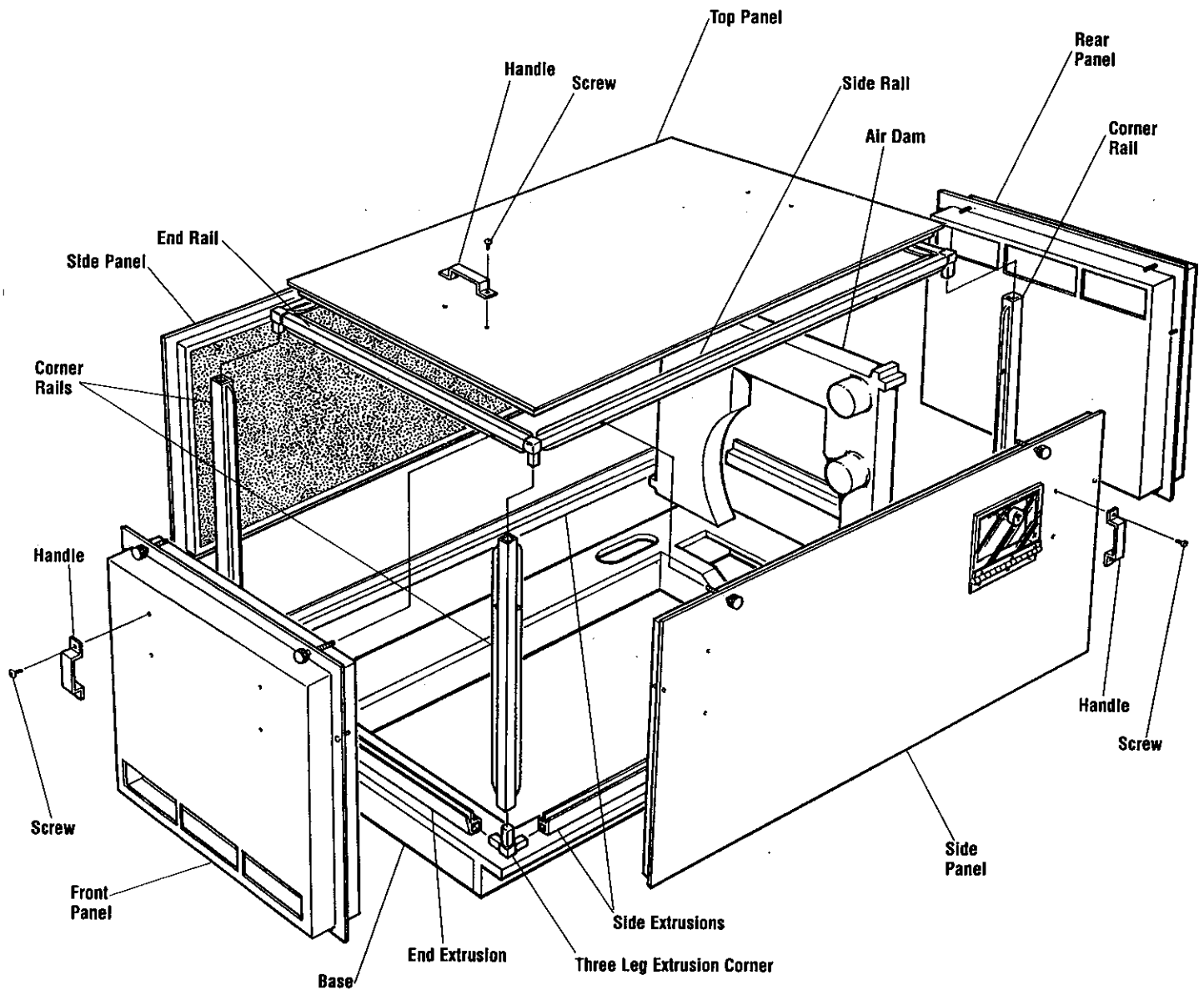
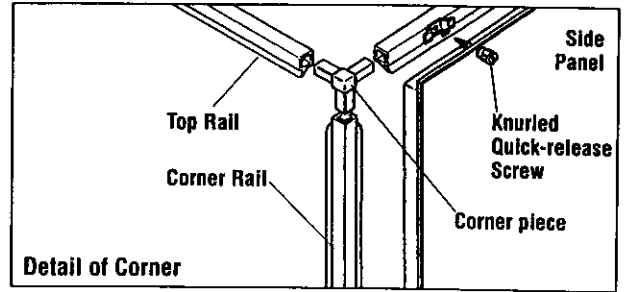

**FOR THE 11 BTDA, 12.5 BTDA, AND 15 BTDA GENERATOR SETS SOUND GUARD #38771**

WESTERBEKE Sound Guards are built around a simple design which allows easy assembly and disassembly. All connections (exhaust, water, battery, fuel, instruments) are made through the lower skirts. Thus all parts of the engine and generator can be reached for service by simply removing the panels and framework, for which no tools are needed. This design permits Westerbeke to offer Sound Guard for every generator set in its line. All sound absorbent lining on the interior of the panels is mylar faced for cleanliness.

The Sound Guard must be installed so that there is ample air circulation near the intake grill, at the rear of the generator, and the discharge duct, at the front of the engine. These air channels should be at least 6 inches from any obstruction. Tests at 95°F ambient show that the air at the discharge duct will be about 150°F. The generator receives an ample supply of cooling air, combustion air, and evacuation air via a large capacity fan between the flywheel and generator, so that a front fan is not needed.

**PREPARE THE GENERATOR SET 11 BTDA, 12.5 BTDA, OR 15 BTDA FOR SOUND GUARD:**

1. Uncrate both the generator set and Sound Guard. Check the contents against packing list. Remove and discard the louvered cover on the back end of the generator (Figure 1). The louvered cover is attached with four metric screws, which should be saved for use in Step 7.
2. Hoist the generator set to a comfortable working level.
3. Remove the plastic belt guard.
 

CAUTION: With the front Sound Guard panel removed, the front pulleys and belt are exposed. Caution should be used when the front Sound Guard panel is off and the engine is running.
4. Attach the cover kit #37298, which will close the two rectangular holes in the bottom of the generator housing. This is to prevent recirculation of air within the enclosure.
5. Install generator air plenum #38770, which consists of two parts: the main plenum frame, and a right angle bracket. For ease in shipping, these parts are not attached. The 3 screws used to attach the two parts are already screwed into the main plenum frame. Attach the right angle bracket tightly to the main plenum frame so that the bracket is flush with the upper edge of the large rectangular cut-out in the plenum.
6. Attach the plenum to the generator with the 4 metric screws snugly.
7. Attach forward edge of the right angle bracket to the generator with two metric screws left over from Step 1.

**INSTALL THE GENERATOR SET IN THE SOUND GUARD:**

These installation instructions apply for the 11 BTDA, 12.5 BTDA, and 15 BTDA generator sets, though there are slight differences in the installation of each.

1. It will be more convenient at this point to remove both the front and rear skirts from the Sound Guard Base Assembly for better visibility. Remove the two ¼ inch cap screws that hold the part, loosen the adjacent screws of the side skirts about two turns. The rear skirt and its attaching parts will slide out.
2. With generator set still suspended, two people can lift the Sound Guard plywood base assembly bolts into their corresponding holes in the generator mounting rails. The plywood base will have two bolt patterns, the larger configuration fitted for the 15BTDA rails, and the smaller configuration for both the 11BTDA and the 12.5BTDA rails (Figure 3). Make sure that the skirt with the large exhaust ports is at the generator end of the unit, and that the skirt with the water inlet port is at the front of the engine. Spin the bolts in finger-tight, lower the generator set into position, and tighten the bolts.
3. The 11 BTDA and 12.5 BTDA generator sets have their exhaust ports opposite the exhaust port for the 15 BTDA in the rear Sound Guard skirt. Ports have been cut at both ends in order to commonize the part. Close whichever exhaust port remains unused by your generator set with closure #37388. Attach the 45 degree water injected exhaust elbow, made of corrosion resistant ALMAG 35, to the usable exhaust port. Connect the exhaust hose between elbow and exhaust manifold.
4. Run fuel, battery, and power connections through the skirt, positioned conveniently to the installation. It is easier to remove the Sound Guard skirts to drill holes for the fuel, battery, and power leads than to do this operation with the skirts in place. Two fuel supply and return adapters #23991 are provided.
 

IMPORTANT: If exhaust manifold is at or below water line, then a siphon break is mandatory between the raw water outlet of the heat exchanger and the water inlet on the exhaust elbow. The siphon break valve should be at least 12 inches above the water line. The hose may be run in and out of the side skirt (study Service Bulletin #177 enclosed).
5. Attach water inlet elbow #36624 to front skirt, and connect sea water hose (wire inserted type) between the elbow and pump suction.
6. Assemble Sound Guard framework using three and four-leg extrusion corners.
7. Place side, end, and top panels onto Sound Guard framework using the guidepins to align the panels to the framework. Each panel attaches to the framework with two finger-workable screws.

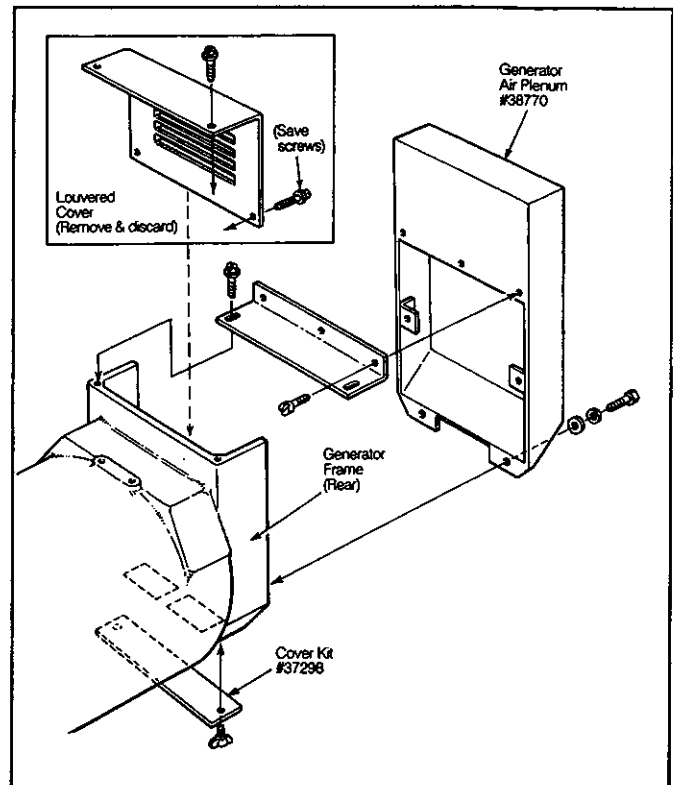

Figure 1. Plenum Mounting

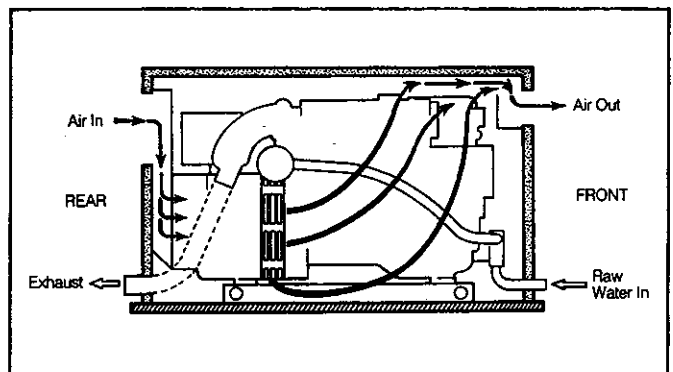

Figure 2. Air Flow Diagram

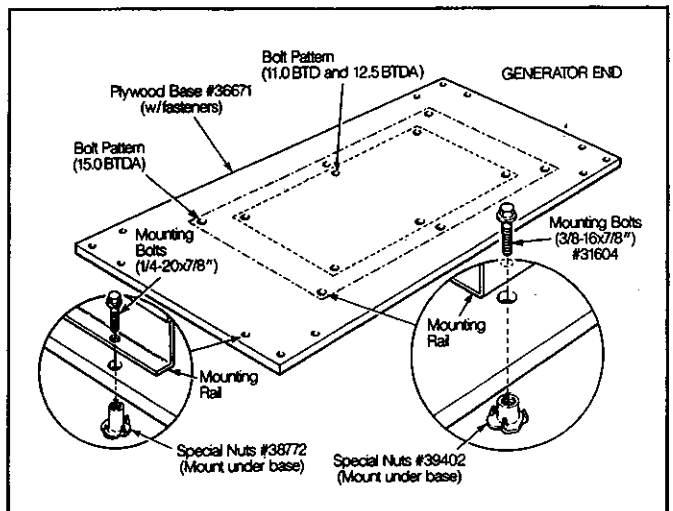
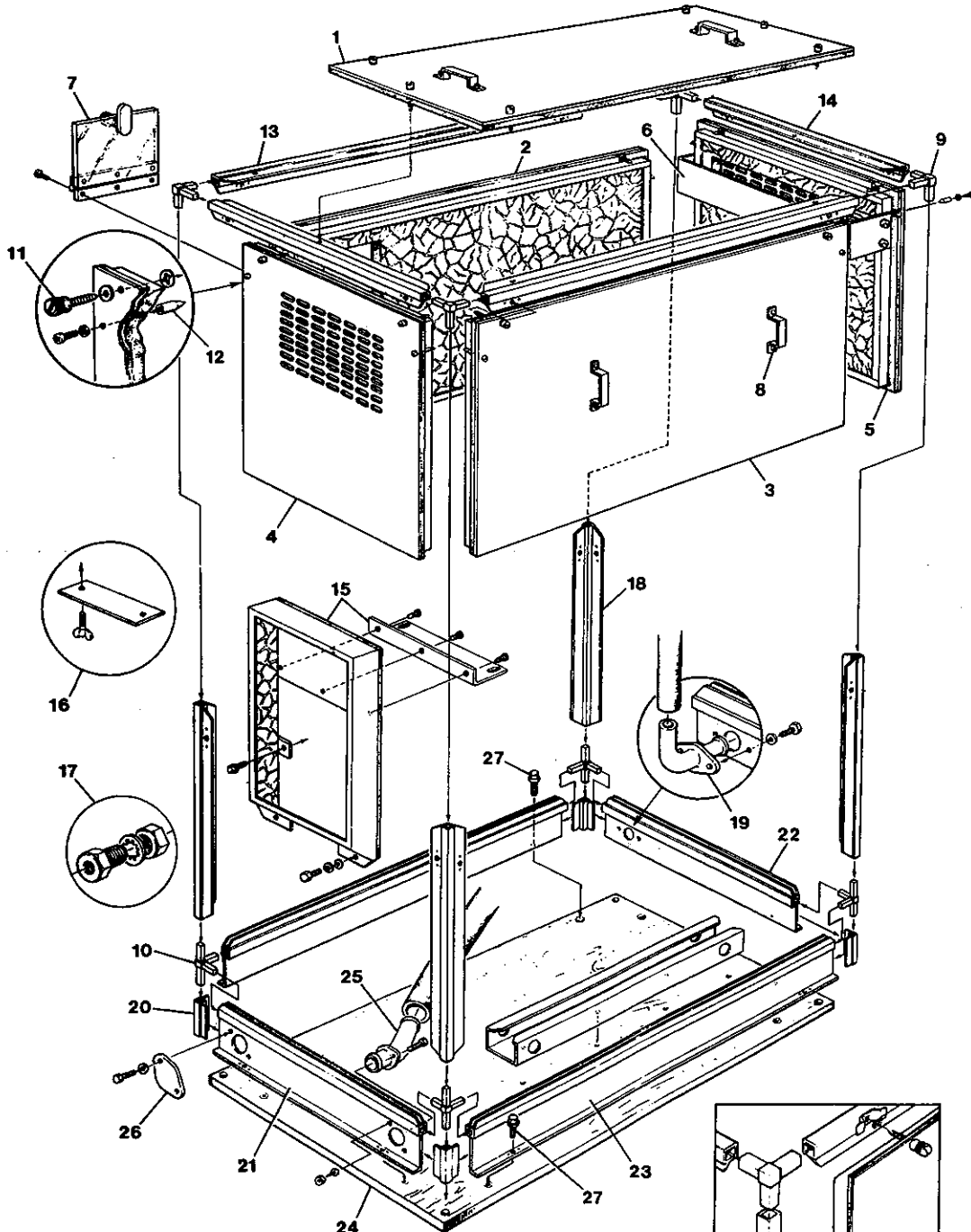

Figure 3. Sound Guard Base with Generator Mounting Hardware

**SOUND GUARD ASSEMBLY #38771 and PARTS REORDERING LIST**

KEY NO.	PART NO.	DESCRIPTION	QTY	KEY NO.	PART NO.	DESCRIPTION	QTY
1	38768	Panel, Top	1	15	38770	Air Plenum IN	1
2	38766	Panel, w/Window	1	16	37298	Cover Kit	1
3	38767	Panel, Plain	1	17	23991	Fuel-IN and OUT	2
4	38765	Panel, Rear	1	18	38851	Post, Corner	4
5	38764	Panel, Front	1	19	36624	Raw Water Inlet	1
6	38769	Vent, Air Out	1	20	30880	Corner Closure	4
7	35223	Window Assembly	1	21	38856	Skirt, Rear	1
8	35720	Handle, Panel	6	22	38855	Skirt, Front	1
9	24057	3 Legger Casting	4	23	38854	Skirt, Side	2
10	24058	4 Legger Casting	4	24	36671	Base, w/Fastenings	1
11	30895	Quick Screw	10	25	36744	Exhaust Outlet	1
12	30775	Alignment Pin	12	26	37388	Exhaust Hole Cover	1
13	38852	Rail, Side	2	27	31604	Cap Screw, 3/8-16x7/8"	6
14	38853	Rail, End	2				

NOTE: When ordering replacement panels, use the part number listed. If a complete Panel Assembly is required, add the word "Assembly" after the part number.



WESTERBEKE CORPORATION  
 AVON INDUSTRIAL PARK, AVON, MA 02322 • TEL: (508) 588-7700

## INSTRUCTIONS WITH FAN REQUIREMENT

1. Plywood base, generator set bolts and skirt are in place as received.
2. Hoist the generator set enough so that two men can lift the plywood base and enter the bolts into corresponding holes in the generator set rails. Spin nuts finger tight. Assembly may then be lowered into position and bolting completed.
3. The generator set and base may then be bolted to the sub-base through holes in corner of the plywood.
4. To assemble frame, see Figure 1. Be sure that open holes are opposite guide pins and that riveted screw receptacles are opposite screws.
5. On units which require a fan follow this procedure:
  - A. Remove the belt guard and discard.
  - B. Remove 4 screws which secure fresh water pump pulley.
  - C. Reassemble on pulley with spacer, fan and 4 cap screws. Tighten securely.
6. Holes for fuel lines, battery cables, remote panel cable, and power lines are to be cut in the lower skirt by the installer. These holes should be cut to minimum usable size in order to minimize the escape of sound.
7. Make a final check to be sure fan has clearance in its opening, that the fresh air duct from intake plenum to engine air intake is clamped in place, and that there is a tight fit of air plenum against the end of the generator to prevent re-circulation of air.
8. If you plan to order SOUND GUARD, order the generator set with remote panel and cable extension.

**CAUTION:** With the air discharge end panel removed, the fan is exposed and unprotected. **DO NOT** remove air discharge end panel without first stopping engine.

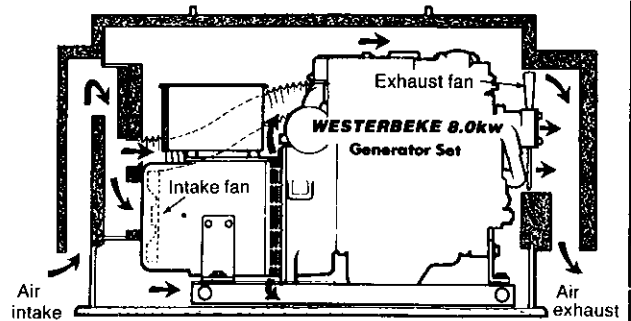

Figure 1. Sound Guard Air Flow Diagram

Figure 2, below, demonstrates the simple design around which WESTERBEKE Sound Guards are built. They are easily assembled or disassembled in place. All connections (exhaust, water, battery, fuel, instruments) are made through the lower skirts. Thus, all parts of the engine and generator can be reached for service by removing the panels and framework, for which no tools are needed! All sound absorbent lining is mylar faced for cleanliness. This design permits WESTERBEKE to offer Sound Guard for every generator set in its line.

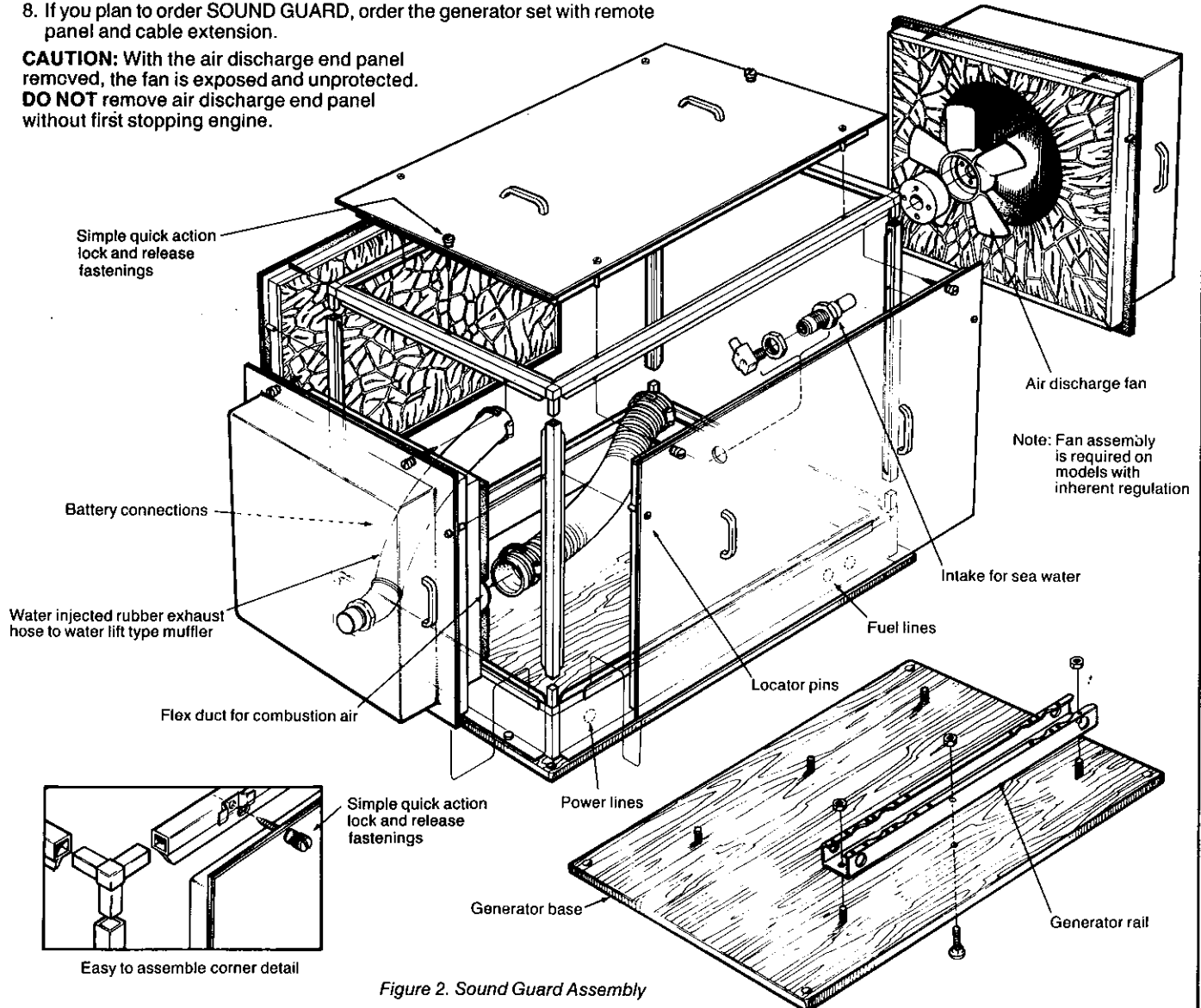

Figure 2. Sound Guard Assembly

**TO INSTALL 8 BTD GEN SET IN #34850 SOUND GUARD**

The #34850 SOUND GUARD differs from preceding models in that no front fan is needed. A large capacity fan between the flywheel and generator is ample to supply cooling air, combustion air, and evacuation air. Tests at 95°F ambient and full output show that the discharge air at front duct #34707 will be about 150°. The installation must be planned so that there is free circulation of air around the Sound Guard (see Figure 3). The front duct #34707 should be at least 6 inches from any obstruction and the same rule applies to the intake grill #34792.

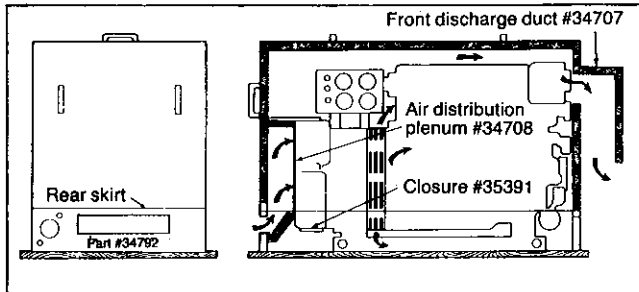

Figure 3. #34850 Sound Guard

**PREPARE THE GENERATOR SET FOR THE SOUND GUARD**

1. Uncrate the set, and discard the louvered cover on the back end of the generator. Save the metric screws which hold it on.
2. In its place, install the air intake plenum from the Sound Guard Kit (Part #34708). Use care when tightening the metric 6 x 15 mm screws and washers supplied. These are screwed into the aluminum casting. Over-tightening may strip the threads.
3. Install the two #35391 closures in the two rectangular holes cast in the bottom of the generator frame (see Figure 4). Due to irregularity in the casting some clips may require light bending in or out to fit snugly. These closures are necessary to prevent recirculation of hot air within the Sound Guard enclosure. This operation is most easily done in the shop by hoisting the generator set to a comfortable working height for good visibility.

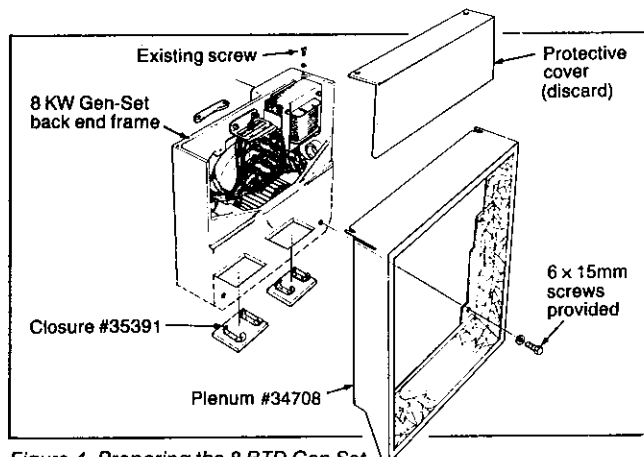

Figure 4. Preparing the 8 BTD Gen Set

**INSTALL THE GENERATOR SET IN THE SOUND GUARD**

4. It will be more convenient at this point to remove rear skirt #34792 from the Sound Guard Base Assembly. Remove the two 1/4" cap screws that hold the part, loosen the two adjacent screws of the side skirts about two turns, and Part #34792 and its attaching parts will slide out.

5. Now hoist the generator set enough so two men can lift the Sound Guard plywood base assembly bolts into their corresponding holes in the generator set rails.

The generator end goes toward rear skirt #34792. Spin the nuts on finger-tight, lower the generator set into position, and tighten the four nuts.

6. At this point, follow general instruction #6 in the Sound Guard brochure and place fuel, battery and power connections in the skirt, positioned convenient to the installation. Water and exhaust holes are already supplied as are fittings and hoses. Note that it is easier to remove the sound guard skirts to drill for the fuel, battery and power leads than to do this operation in-place. See Figure 5 for sea water piping.
7. The exhaust hose, being wire inserted, is hard to push on to the fittings, so grease the inside of each end for about 2".
8. With all skirts replaced and all service connections made, assemble the frame components and the panels using Figure 2 as a guide. At this point the front engine pulley screws should clear the front panel foam by 1/16 to 1/8 of an inch. The rear panel foam should press against the intake plenum to make a tight seal preventing recirculation of air. If this joint is open by more than 1/8 inch, add a strip of the 3/4" foam gasketing supplied to rear edges of plenum #34708.
9. If your 8BTD Sound Guard was the early model supplied with pipe fittings and nipples to connect the exhaust hose, be sure to wrap the dry sections with heat resisting material to reduce the temperature within the box.

8BTD Sound Guards from January 15, 1986 onwards will be fitted with 45 degree water injected exhaust elbows. These elbows as well as exhaust outlet elbow #32204 will be cast of ALMAG 35. Corrosion resistance of ALMAG 35 is the highest of any aluminum casting alloy. This results from the almost complete absence of heavy metals, which induce the electrolytic type of corrosion in other alloys. In addition, the relatively high magnesium content gives it further protection against corrosion from mild alkalis, salt spray, sea water. ALMAG 35 castings are being used in the manufacture of axial flow pumps, which are jet propelled motors for boats used in sea water. The unanodized ALMAG 35 parts are not subject to corrosion even though the pumps contain bimetal couples with stainless steel and Monel metal.

Early 8BTD models may not have had the two cast holes in the alternator frame which require two closures #35391. On the other hand, it is possible to have the two holes and be without the closures. Check carefully and contact the factory or your Master Distributor for assistance or clarification.

**WATER AND EXHAUST PIPING**

The elbow at the top of the raw water pump must be turned (approx. 80°) to prevent the hose from rubbing against the side. The raw water elbow at the exhaust points straight down and the 27" raw water hose connects forward to the heat exchanger. See Figure 5.

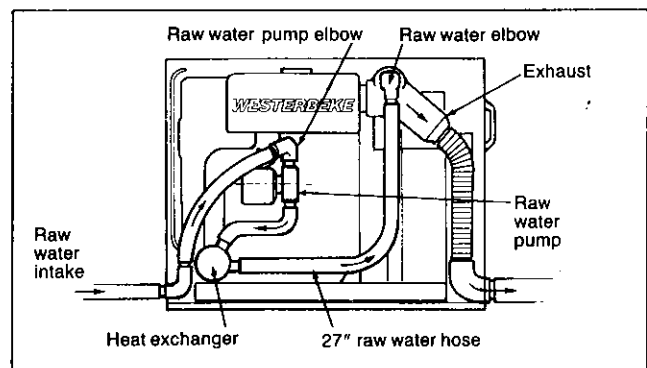

Figure 5. 8 BTD Gen Set

**TO INSTALL 4.4 BCD and 6 BCD GEN SETS**

The 4.4 BCD and 6 BCD generator sets fit within the 8 BTD Sound Guard. There are differences in the rear skirts and plenums, which become evident on assembly. In general the instructions for the 8 BTD are adequate guidance. Study the illustrations: Figure 6 for the 4.4 BCD and Figure 7 for the 6 BCD. Also see Figure 8 for the plenum mounting detail.

**TO INSTALL 15 KW and 20 KW GEN SETS**

On 15 KW and 20 KW sizes equipped with advance alternators, the air intake and distribution plenum is mounted directly on the back end of the alternator by means of four cap screws and four clips #35252. This assembly must be done before the set is mounted on its plywood base and is most easily performed by two men in the following sequence (see Figure 9):

1. Be sure that no corners of the expanded metal screens over the alternator's air intake ports protrude over the machine surface around the back end of the machine. (The front half of the plenum #35249 must lie flat against this machined surface.)
2. While one man holds Part #35249 flat and central, the other installs bolt and clip #35252 in the northeast position lightly so that Part #35249 can be rotated counterclockwise until bolt and clip #35252 can be easily installed in the northwest position. Again, lightly.
3. Install bolt and clip in the southeast position lightly.
4. Rotate plenum #35249 so that the fourth bolt and clip #35252 can be installed in the southwest position.
5. Rotate plenum to permanent vertical position and tighten bolts firmly but not excessively. Remember, the force you apply is exerted against a 1/4" ring of aluminum already undercut to accommodate clip #35252.
6. Now the rear half plenum #35230 may be fastened in place by its spring latches and the air-to-engine elbow #32590 fastened on with the screws supplied.
7. Lastly, install closure Part #35724 over the cast slots in the bottom of the alternator frame just forward of the plenum. This is important as it prevents recirculation of air through the alternator and allows the full force of the cooling fan to expel heated air from the enclosure:

At this point, lift the generator set and assemble the base as described in the original instructions. Continue installation using instructions selectively. See Figure #10 as a guide to cooling water and combustion air connections.

As a final check: 1) assure that the engine fan has clearance in its opening and is approximately 1/3 inside the opening, and 2) be sure that the opening in rear plenum #35230 is very close to the opening in the rear panel. An ideal fit would be for the plenum #35230 to depress the foam of the rear panel by 1/16 of an inch. Any opening at this point over 1/8 of an inch should be closed by the addition of adhesive backed gasketing.

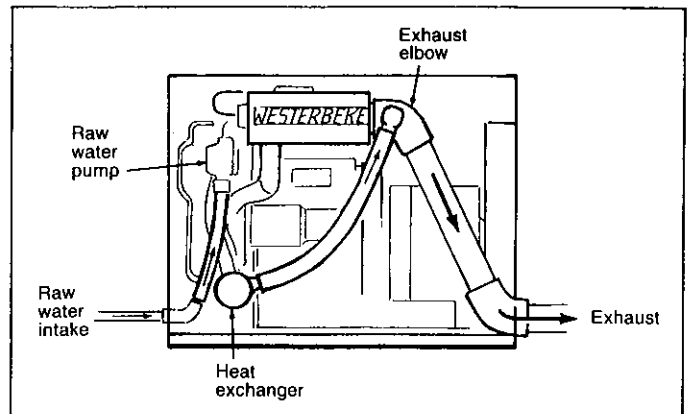

Figure 6. 4.4 BCD Gen Set

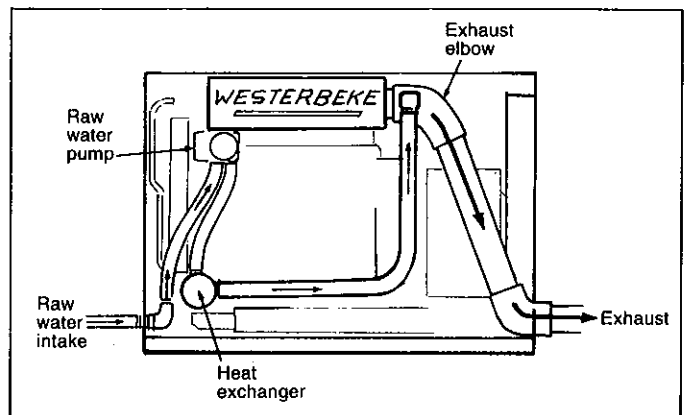

Figure 7. 6 BCD Gen Set

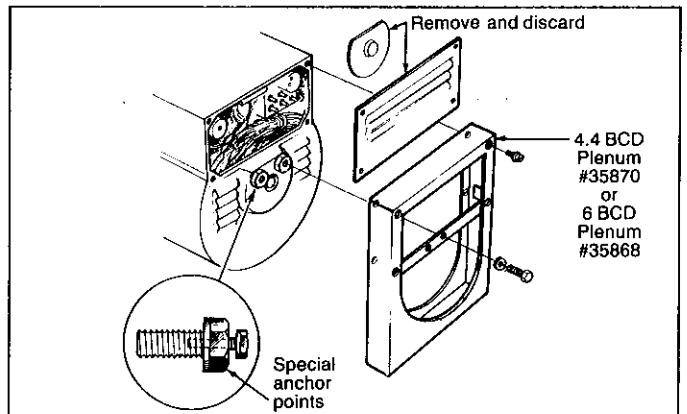

Figure 8. Plenum Mounting (4.4 BCD and 6 BCD)

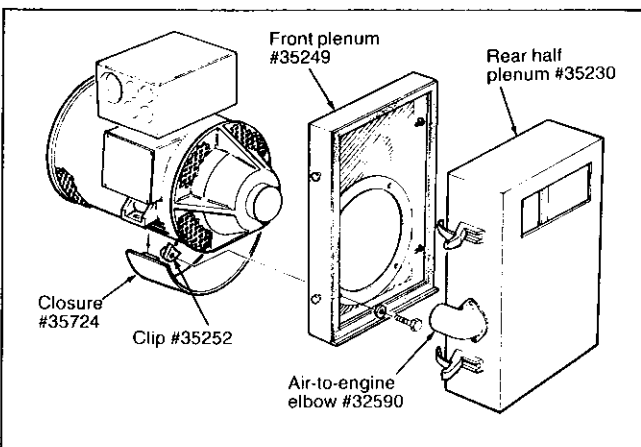

Figure 9. Plenum Mounting (15 KW and 20 KW)

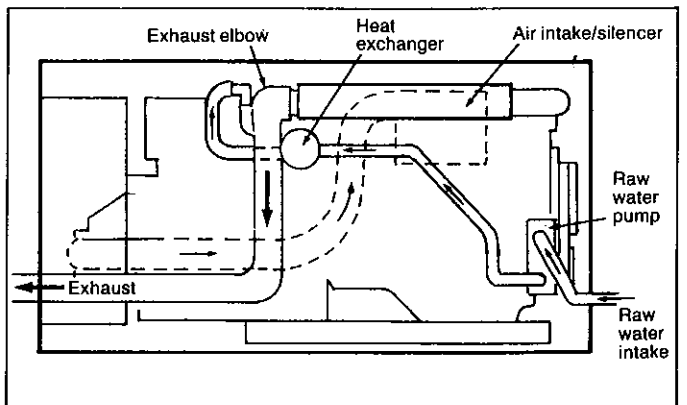

Figure 10. 15 KW and 20 KW Gen Sets

**TO INSTALL 25 KW, 32 KW and 45 KW GEN SETS**

These generator sets also have the air intake plenum mounted directly on the back end of the alternator (see Figure 11). Attach plenum #35250 before mounting the generator set on the Sound Guard base, as follows:

1. Remove and discard protective cover over exciter.
2. Remove four  $\frac{3}{8}$  bolts that secure rear bearing bracket to generator frame.
3. Place front plenum (Part #35250) against back end of alternator and secure by the same four bolts.
4. Place rear half plenum (Part #35750) in position and secure by four spring latches.
5. Screw air-to-engine elbow #32590 to appropriate side of plenum and blank off the opposite side (left side for 25 KW and 32 KW, right side for 45 KW).

The next operation is to mount Sound Guard base to generator set and set the assembly in place. Make certain there is working room around the set and that there is unrestricted air flow to air intake and outlet ducts.

Now complete fuel, water, battery and power connections through the skirts as best suits the installation. Note that it is easier to remove a skirt section for drilling in the shop than to drill in place (see Figure 12).

On the 32 KW plant, sea water flow from the heat exchanger should be divided by a  $\frac{1}{2}$ " or larger tee at the inlet to the injected exhaust elbow so that only the necessary portion flows through the exhaust and so that the remaining portion has an unrestricted run back to the ocean. It is the installer's responsibility to balance these two flows so that adequate cooling water flows through the exhaust to cool it at full load and speed (see Figure 13). This paragraph applies also to 45 KW set.

**GENERAL CAUTION:**

Any Westerbeke generator that is to be installed in Sound Guard must have belt guard removed and discarded.

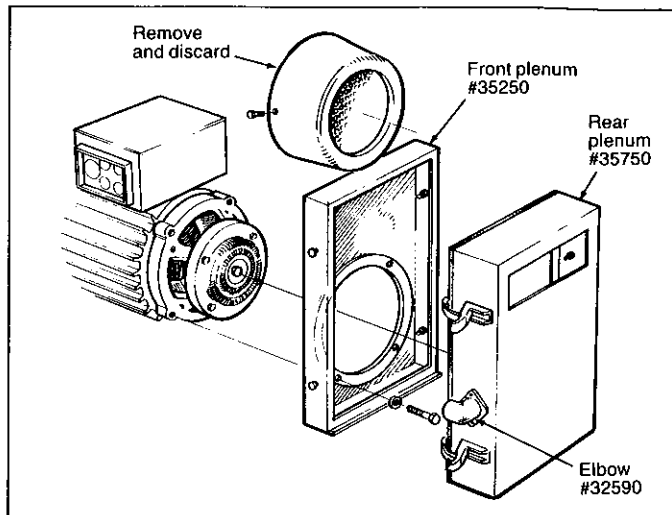

Figure 11. Plenum Mounting (25 KW, 32 KW and 45 KW)

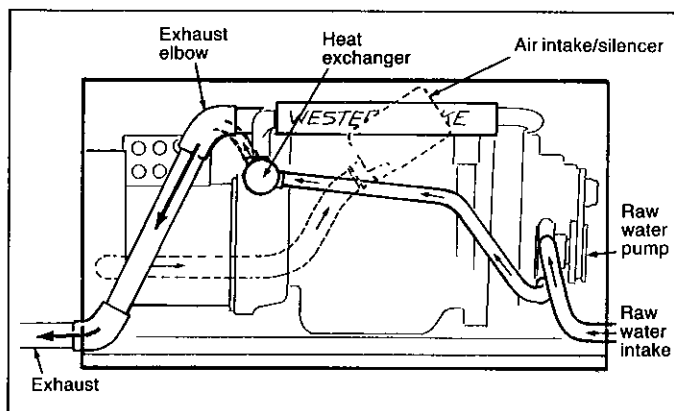

Figure 12. 25 KW Gen Set

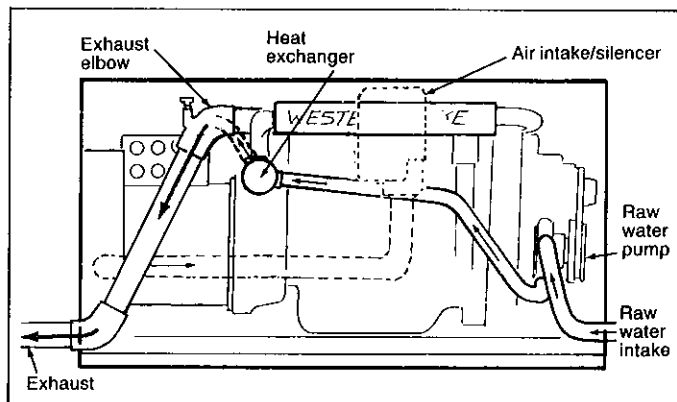

Figure 13. 32 KW Gen Set

# 8.0 BTD & 10.0 BTD SOUND GUARD INSTALLATION

**NOTE:** *Drilling the access holes for fuel, battery and power leads in SOUND GUARD with skirts removed from the base is much easier than attempting the operation with the skirts in place.*

8. The exhaust hose is wire-inserted and, as such, may be difficult to push onto the exhaust fittings. Lubricating the inside of the exhaust hose ends (approximately two inches) will make this easier to do.
9. After all the service connections have been made, replace the skirts and assemble the frame components using the illustration below as a guide.

At this point the front engine pulley screws should clear the front panel foam by 1/16 to 1/8 of an inch. The rear panel foam should press against the air intake plenum to make a tight seal preventing the recirculation of air. If this joint is open more than 1/8 of an inch, add a strip of the 3/4 inch foam gasket material (supplied) to the rear edges of the plenum.

10. The elbow at the top of the raw water pump must be turned approximately eighty degrees to prevent the hose from rubbing against the side panel of the SOUND GUARD. The raw water elbow at the exhaust should point straight down and the raw water hose connects forward to the heat exchanger.
11. The panels (side, top, front and rear) are fastened to the corner posts and rails with knurled quick release screws. Care should be taken to not over-tighten these screws.

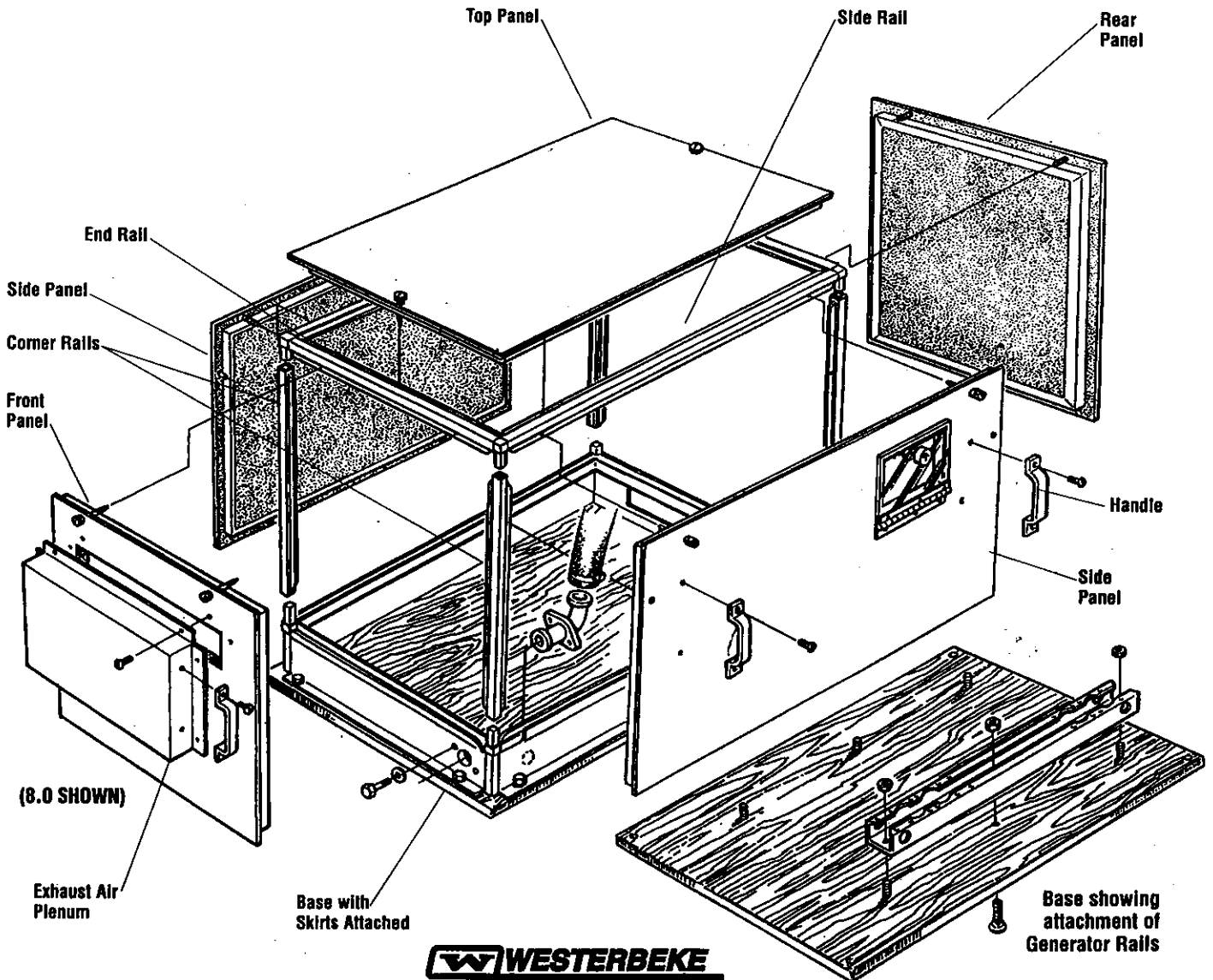
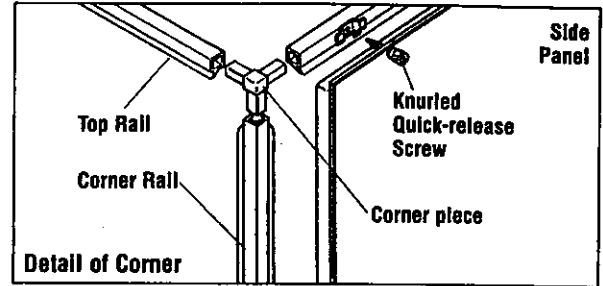

# 8.0 BTD & 10.0 BTD SOUND GUARD INSTALLATION

## INTRODUCTION

The 8.0 BTD and 10.0 BTD SOUND GUARDs utilize the large capacity fan between the flywheel and generator to supply cooling air, combustion air and evacuation air. The installation must be well planned so that there is free circulation of air around the SOUND GUARD. The front duct and the intake grill must be at least six inches from any obstruction outside the SOUND GUARD.

## PREPARING THE GENERATOR FOR THE SOUND GUARD

1. Uncrate the SOUND GUARD and locate the base assembly, 2 side panels, front and rear panels, top panel, air intake plenum, rails, posts, corner pieces, and bag with assorted hardware and other items needed for constructing your SOUND GUARD.
2. Uncrate the generator and discard the protective cover on the back of the generator. Save the screws which held it on.
3. Replace the protective cover with the air intake plenum from the SOUND GUARD kit as illustrated. Use care when tightening the metric 6 x 15mm screws and washers supplied. As they are being screwed into an aluminum casting, over-tightening may strip the threads.
4. Install the two closures into the two rectangular holes cast in the bottom of the generator stator housing. Due to irregularity in the casting, some clips may require light bending in or out to fit snugly. These closures are necessary to prevent recirculation of hot air within the Sound Guard enclosure.
5. **8.0 Only:** Mount the air exhaust plenum on the front panel using the six screws provided. Insert the guide pins in the front panel after assembling the air exhaust plenum and the front panel.

**NOTE:** This operation is most easily done in the shop by hoisting the generator set to a comfortable working height for good visibility.

## INSTALLING THE GENERATOR IN THE SOUND GUARD

6. Set the generator on the SOUND GUARD plywood base assembly so that the bolts in the base align with the corresponding holes in the generator set rails. The generator end (with the air intake plenum attached) goes toward the rear skirt. When the generator is set into position, tighten the four nuts.
7. Cut holes in the skirt for the fuel, battery and power connections, ensuring that they are positioned convenient to the installation of the generator. Use the supplied bushings to prevent the connections from unnecessary wear and tear. Water and exhaust holes are pre-drilled through the front and rear skirts, and the appropriate fittings and hoses are provided.

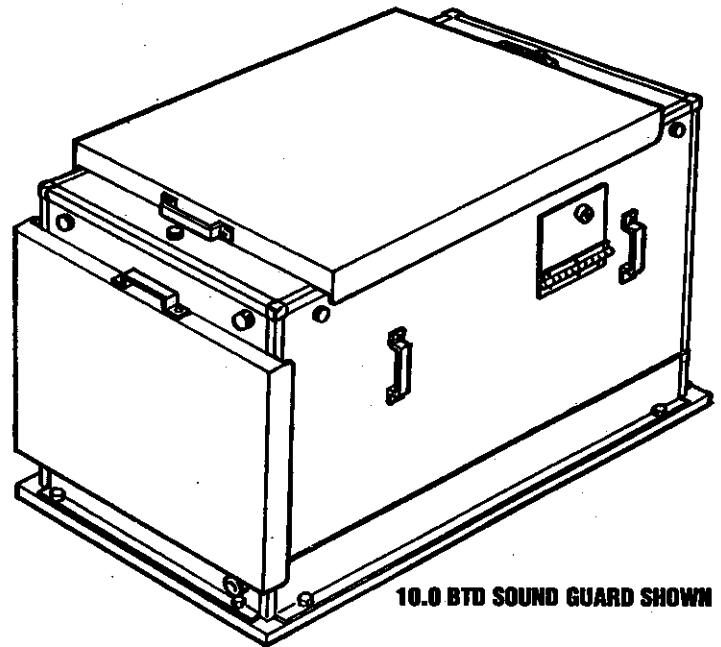

10.0 BTD SOUND GUARD SHOWN

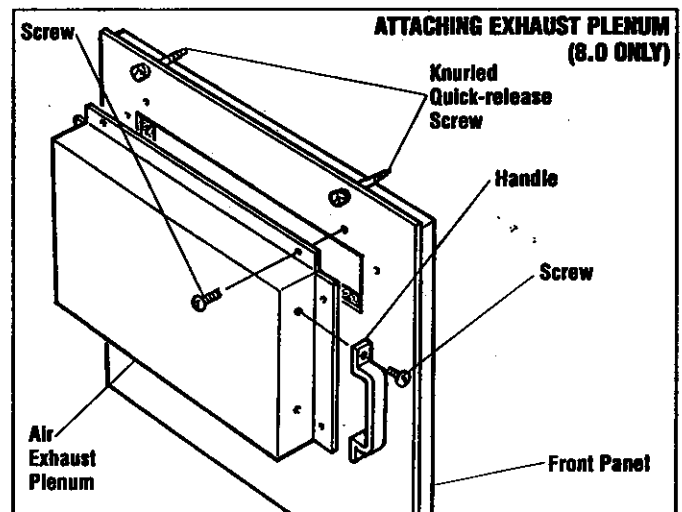
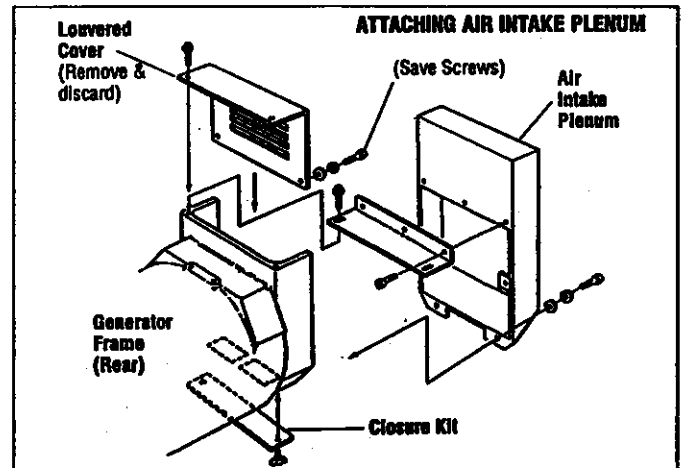

# 5.0 BCDA/B & 7.6 BTD SOUND GUARD INSTALLATION

Water and exhaust holes are pre-drilled through the front and rear skirts, and the appropriate fittings and hoses are provided.

**NOTE:** *Drilling the access holes for fuel, battery and power leads in SOUND GUARD with skirts removed from the base is much easier than attempting the operation with the skirts in place.*

8. The exhaust hose is wire-inserted and, as such, may be difficult to push onto the exhaust fittings. Lubricating the inside of the exhaust hose ends (approximately two inches) will make this easier to do.
9. After all the service connections have been made, replace the skirts and assemble the frame components using the illustration as a guide.

At this point the front engine pulley screws should clear the front panel foam by 1/16 to 1/8 of an inch. The rear panel foam should press against the air intake plenum to make a tight seal preventing the recirculation of air. If this joint is open more than 1/8 of an inch, add a strip of the 3/4 inch foam gasket material (supplied) to the rear edges of the plenum.

10. The elbow at the top of the raw water pump must be turned approximately eighty degrees to prevent the hose from rubbing against the side panel of the SOUND GUARD. The raw water elbow at the exhaust should point straight down and the raw water hose connects forward to the heat exchanger.
11. The panels (side, top, front and rear) are fastened to the corner posts and rails with knurled quick release screws.

**NOTE:** *Care should be taken to not over-tighten these screws as they are being screwed into aluminum, and over-tightening may strip the threads.*

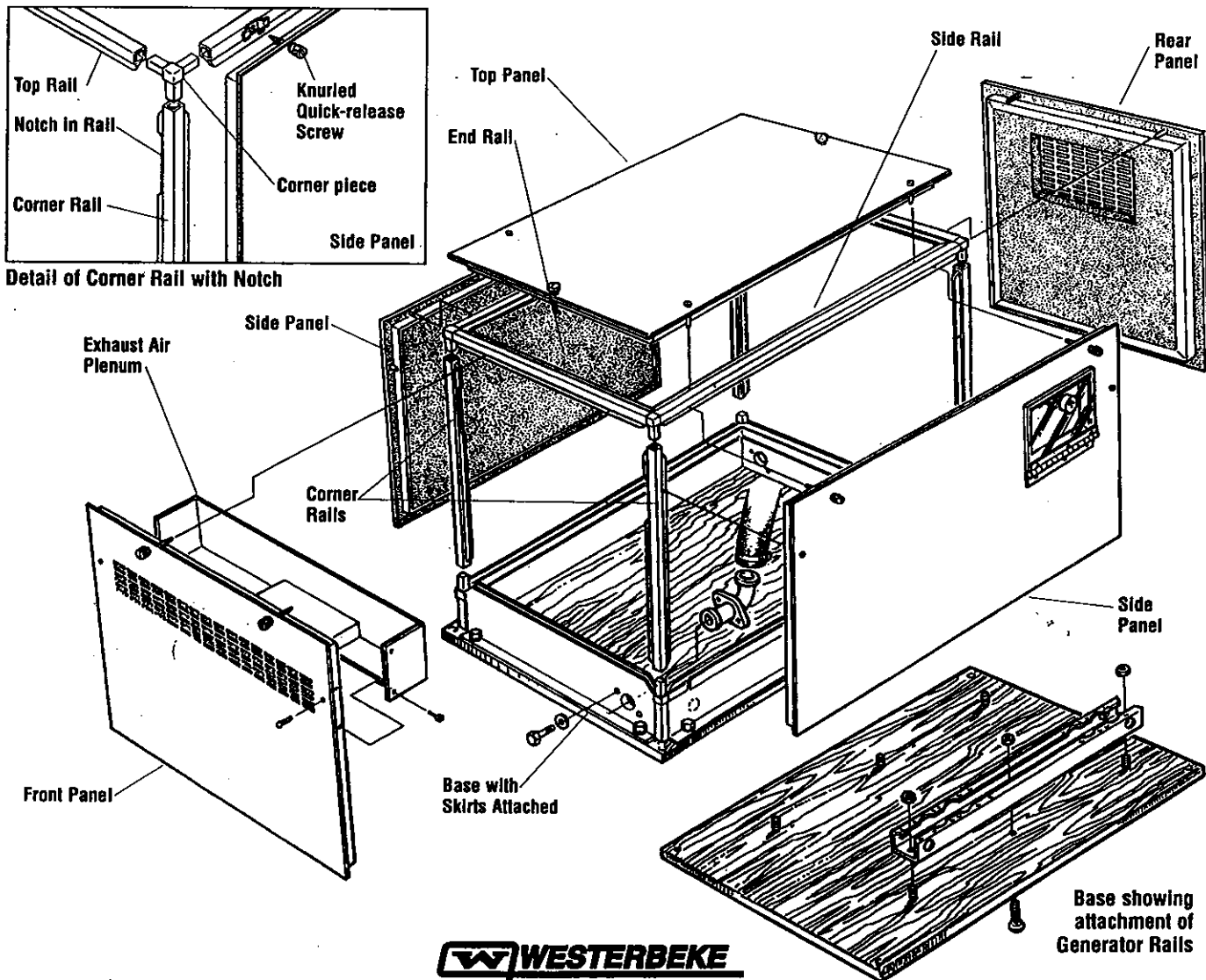

# 5.0 BCDA/B & 7.6 BTD SOUND GUARD INSTALLATION

## INTRODUCTION

The 5.0 BCDA, 5.0 BCDB and 7.6 BTD SOUND GUARDS utilize the large capacity fan between the flywheel and generator to supply cooling air, combustion air and evacuation air. The installation must be well planned so that there is free circulation of air around the SOUND GUARD. The front duct and the intake grill must be at least six inches from any obstruction outside the SOUND GUARD.

## PREPARING THE GENERATOR FOR THE SOUND GUARD

1. Uncrate the SOUND GUARD and locate the base assembly, 2 side panels, front and rear panels, top panel, air intake plenum, rails, posts, corner pieces, and bag with assorted hardware and other items needed for constructing your SOUND GUARD.
2. Uncrate the generator and discard the louvered cover on the back of the generator. Save the screws which held it on.
3. Replace the louvered cover with the air intake plenum from the SOUND GUARD kit as illustrated. Use care when tightening the metric 6 x 15mm screws and washers supplied. As they are being screwed into an aluminum casting, over-tightening may strip the threads.
4. Install the two closures into the two rectangular holes cast in the bottom of the generator stator housing. Due to irregularity in the casting, some clips may require light bending in or out to fit snugly. These closures are necessary to prevent recirculation of hot air within the Sound Guard enclosure.
5. Mount the air exhaust plenum on the inside of the front panel using the four screws provided. Insert the guide pins in the front panel after assembling the air exhaust plenum and the front panel.

**NOTE:** The next operation is most easily done in the shop by hoisting the generator set to a comfortable working height for good visibility.

## INSTALLING THE GENERATOR IN THE SOUND GUARD

6. Set the generator on the SOUND GUARD plywood base assembly so that the bolts in the base align with the corresponding holes in the generator set rails. The generator end (with the air intake plenum attached) goes toward the rear skirt. There should be very little space between the air intake plenum and the rear skirt. When the generator is set into position, tighten the four nuts.

**NOTE:** The air intake plenum should almost touch the rear skirt. This helps ensure the consistent flow of cool intake air to the generator.

7. Cut holes in the skirt for the fuel, battery and power connections, ensuring that they are positioned convenient to the installation of the generator. Use the supplied bushings to prevent the connections from unnecessary wear and tear.

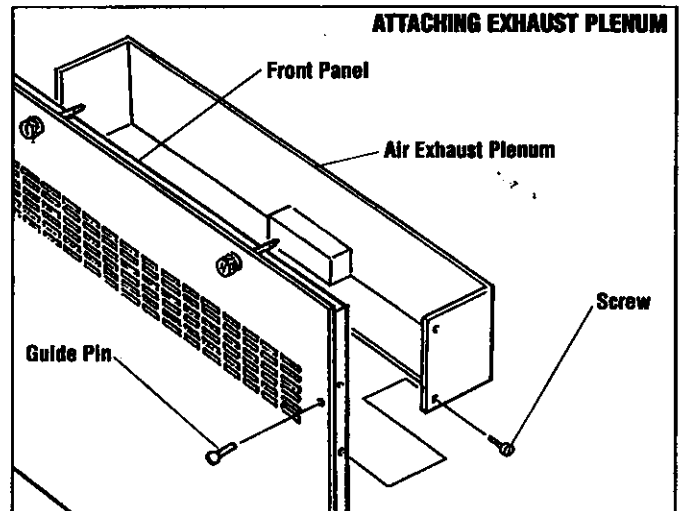
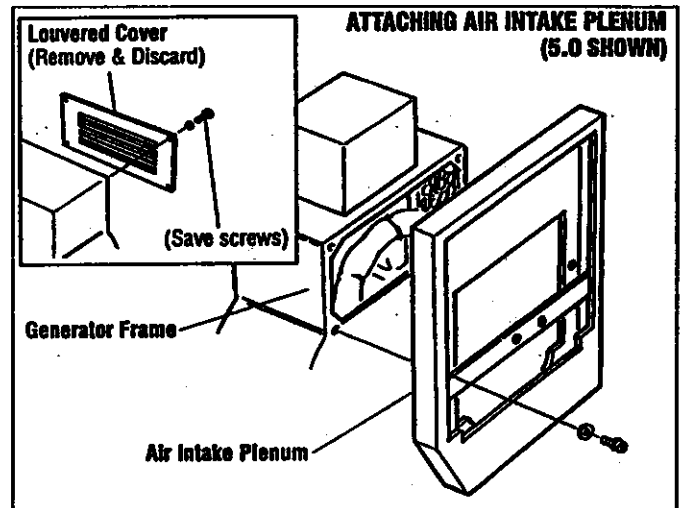
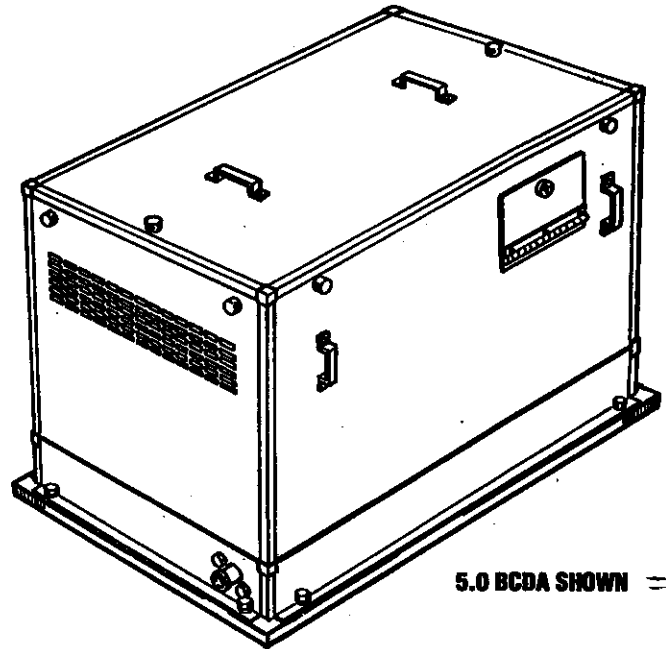



## DRIP PAN/SOUNDGUARD BASE ASSEMBLY

Your WESTERBEKE generator comes complete with a drip pan and a wire reinforced exhaust hose that connects the generator to its exhaust elbow. The drip pan has nine grommets access holes for connecting cooling water, battery cables, AC wiring, fuel lines etc. Simply cut open the grommets that are the most convenient for your installation.

After uncrating, remove and discard the 4 bolts that attach the generator and pan to the shipping pallet. Use the drip pan to mark out the bolt hole pattern on your generator mounting platform. Drill the mounting platform holes and refasten the generator and pan assembly using stainless steel bolts, washers and nuts. When fastening the generator in place, first line up the two aft holes. The two forward holes will then be correctly positioned.

This drip pan is an important part of your generator installation, not only will it help maintain a clean compartment but a drip pan is required in marine installations.

## SOUNDGUARD

The preassembled drip pan provides the opportunity to add a WESTERBEKE SOUNDGUARD to totally enclose your generator. The drip pan is the base for the Soundguard. Five sound insulated lightweight steel panels are easily assembled to this base providing a rugged, compact, sound enclosure. Quick release fasteners and handholds allow for immediate access to your generator.

Contact your WESTERBEKE dealer for more information.

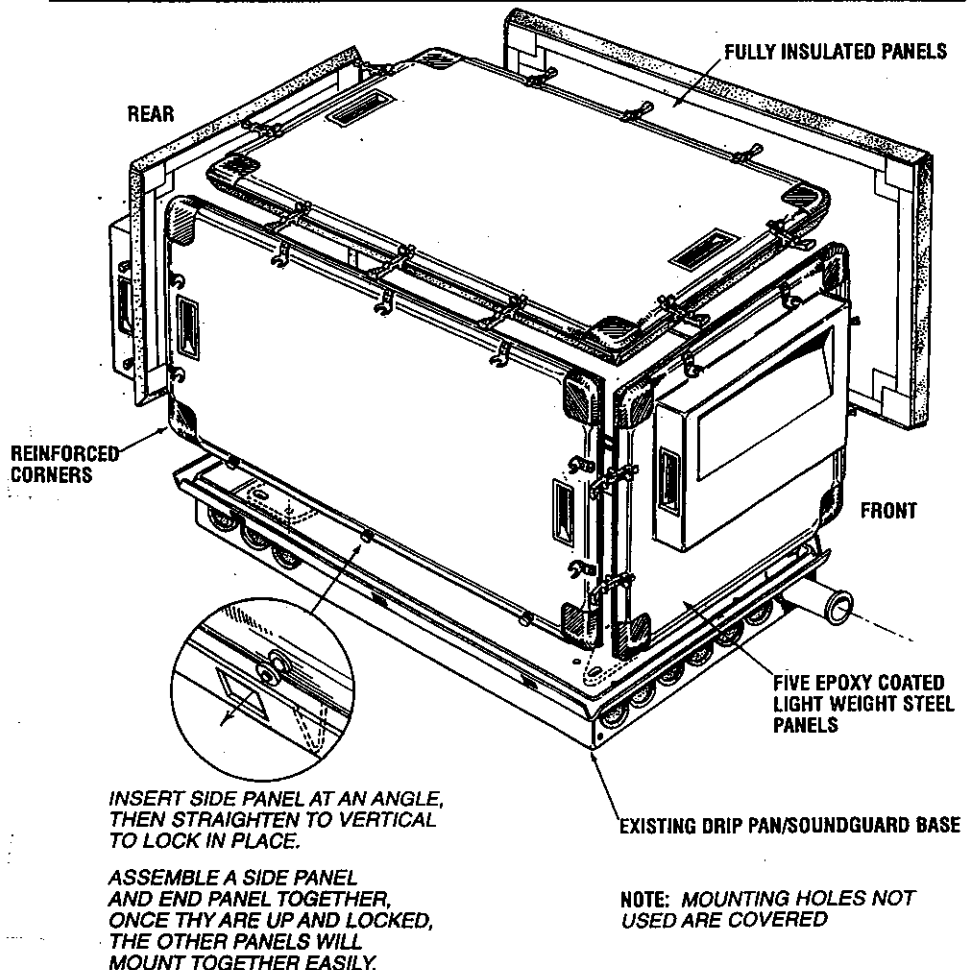
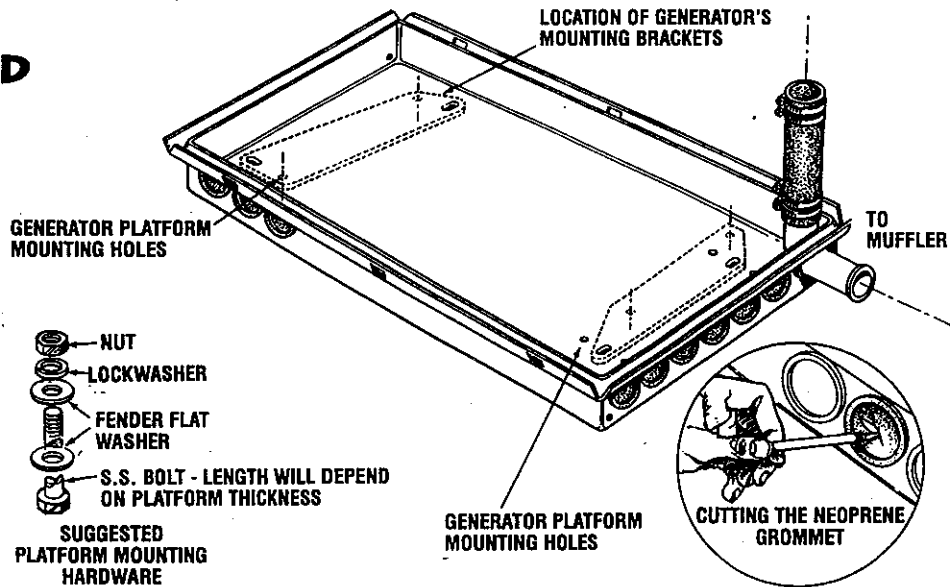

**WESTERBEKE**

WESTERBEKE CORPORATION • AVON INDUSTRIAL PARK  
AVON, MA 02322 • TEL: (508) 588-7700 • FAX: (508) 559-9323

PART NO. 043443