

**WESTERBEKE**

# *Vire*\* 7 h.p.

**inboard reliability for  
the smallest cruisers.**

The VIRE is a 7 h.p. two cycle water-cooled gasoline inboard engine. With its compact dimensions and light weight, it can be used in even the smallest cruisers without noticeably altering trim or sailing qualities. Its 2:1 standard reduction gear will give more useable horsepower to small sailboats than larger engines with direct drive, either inboard or outboard. The design has been completely updated to increase efficiency and horsepower. The VIRE has achieved great popularity because of its small size, economy and dependability.

**REDUCTION GEAR:** Reverse and 2:1 reduction, running in oil, integral with engine, also contains the thrust bearing. There is an attachment drilled for remote control.

**FUEL PUMP AND CARBURETOR:** The diaphragm fuel pump works at all angles of heel. Carburetor furnished with Coast Guard approved flame arrestor.

**EXPANSION CHAMBER:** The built-in water-jacketed expansion chamber cools the exhaust gasses and pre-heats the raw sea water to allow a higher operating temperature.



O'Day 27 by Alan Gurney

Norman Fortier Photo

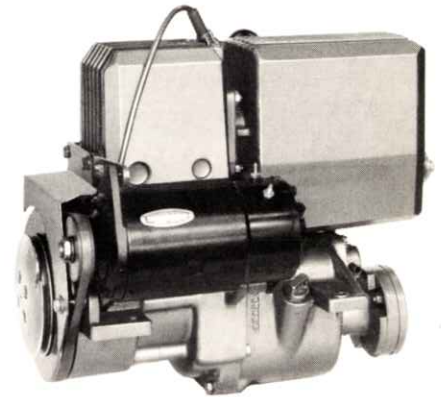
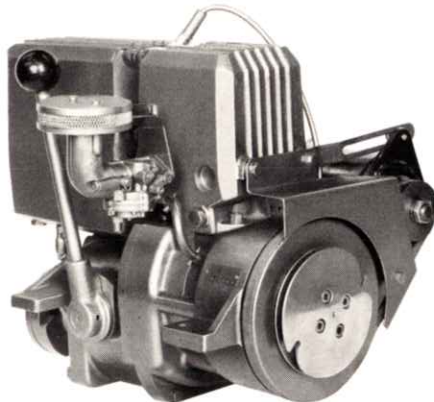
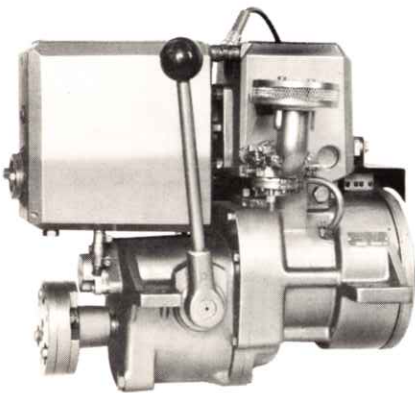

\* Pronounced Vi' reh

WESTERBEKE MODEL  
VIRE 7 PERFORMANCE CURVES.

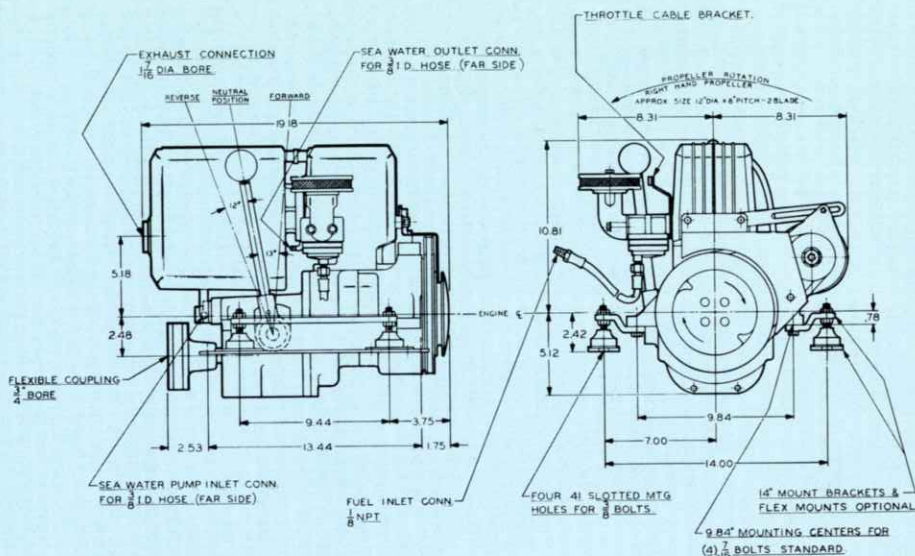
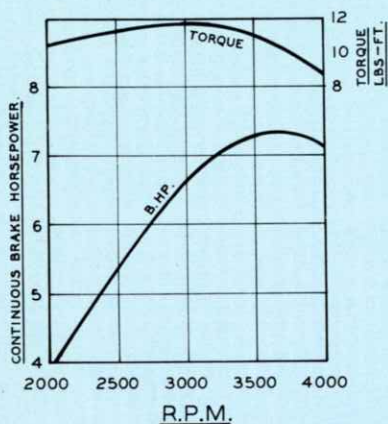

## Specifications

# Vire

## Features

- TYPE:** One cylinder, two cycle gasoline.
- DISPLACEMENT:** 16.3 cu. in. Bore 1.75". Stroke 2.756".
- POWER:** 7 hp at 3200 rpm. (See performance curve.)
- WEIGHT:** 148 lbs. including expansion chamber, reverse and 2:1 reduction gear.
- CYLINDER:** Cast of special alloy.
- CRANKCASE:** Cast iron.
- CRANKSHAFT:** Forged tempered steel.
- PISTON:** Die cast of light alloy with three rings. Top ring is chromium plated.
- BEARINGS:** Ball bearings on both mains. Needle type roller bearing on big end of connecting rod.
- LUBRICATION:** Oil mixed with fuel.
- COOLING:** Rubber impeller type raw water pump of non-corrosive material. Fittings for 3/8" I.D. Hose.
- EXHAUST:** Built-in water-jacketed expansion chamber. Exhaust 1 7/16" I. D.
- ELECTRICAL:** 12 volt Delco-Remy starting motor/generator combination. Charging rate 8-12 amps.
- FUEL PUMP:** Diaphragm pump works at all angles of heel. 1/8" NPT flexible fuel line connection furnished.
- FUEL CONSUMPTION:** Approximately 1/2 gph at top speed.
- INSTALLATION:** 9 13/16" mounting centers. Optional flexible mounts available 14" centers. Maximum angle 15°.
- ROTATION:** Turns a right-hand propeller.
- STANDARD EQUIPMENT:** Electric starting; 2:1 reverse and reduction gear with flexible coupling; water-jacketed expansion chamber; control panel with key switch, charge light and stop control; starter/generator control; flywheel puller; spark plug wrench; thru-hull fittings for water discharge and intake; intake scoop; fuse box; emergency starting cord. There is a special adaption kit for easy attachment of remote control for clutch and throttle cables.

### VIRE RELIABILITY

The VIRE engine has a world-wide reputation for reliability and instant starting. It is built solely for marine use, out of the best marine materials, for rugged duty. It's so simple that there are few things to go wrong, while its light weight permits easy removal to the shop.

The list of standard equipment supplied with VIRE is unusually complete, including special tools, built-in reduction gear and control panel.

Where dependability counts, you can rely on the Westerbeke VIRE. The VIRE is sold and serviced by Westerbeke distributors in major port cities throughout North America.

### WHY AN INBOARD ENGINE?

Many small cruisers and daysailers use outboards for auxiliary power. But an outboard on the transom puts the weight and the propeller in the wrong place. Weight in the ends makes a boat sluggish in a sea way. An outboard propeller may suck air, or even come out of water when the boat pitches. An inboard propeller working in deep undisturbed water is much better.

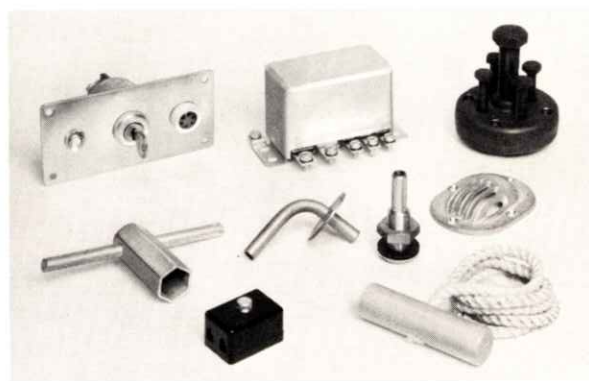

(617) 588-7700

## J. H. WESTERBEKE CORP.

LEDEN AVE., AVON INDUSTRIAL PARK, AVON, MASS. 02322

CABLE: WESTCORP, AVON TELEX: 92-4444