

WESTERBEKE

a rugged, compact,
13 hp marine diesel

13

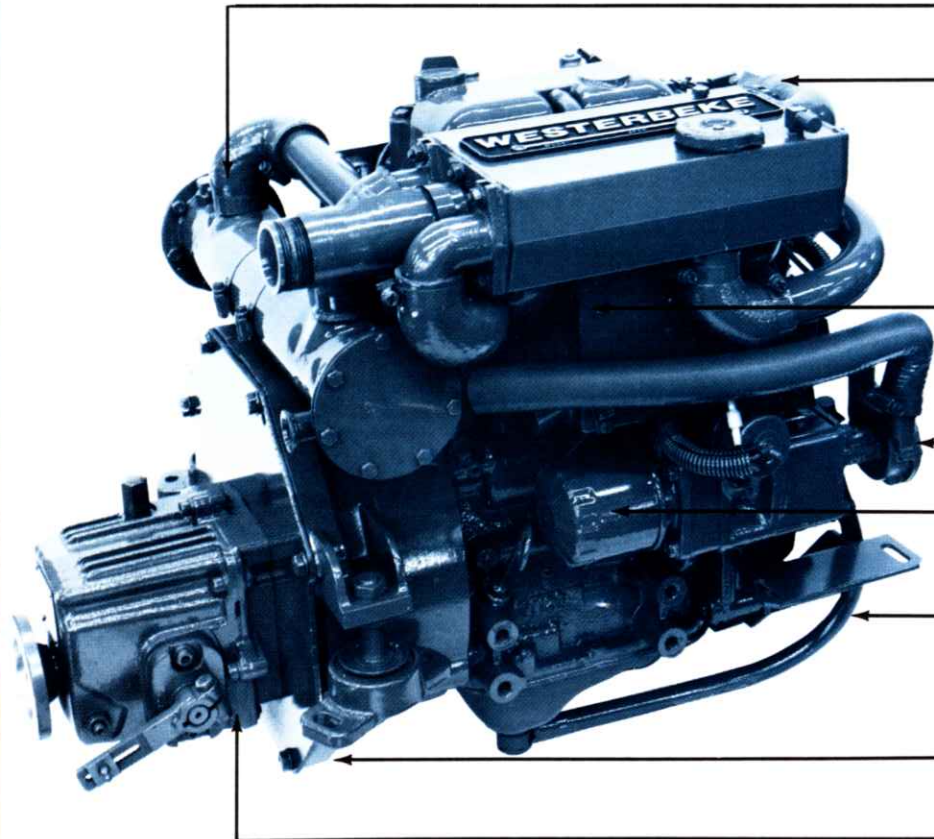

HEAT EXCHANGER WITH
HEAVY DUTY ZINC
ANODES

FRESH WATER COOLED
TWO PASS ALUMINUM
MANIFOLD THAT
INCLUDES A REMOTE
COOLANT RECOVERY
TANK FOR CONTINUOUS
MONITORING OF THE
COOLING SYSTEM

SELF-BLEEDING
FUEL SYSTEM

OVERSIZED RAW WATER
PUMP

SPIN ON OIL FILTER

OIL DRAIN HOSE

ADJUSTABLE FLEX
ISOLATOR ENGINE
MOUNTS 15" ON CENTER

SHORT PROFILE TRANSMISSION

A NEW GENERATION OF MARINE ENGINES

The Westerbeke 13 provides two cylinder, four cycle smoothness in a lightweight, compact engine. Cylinder head and block are of cast iron for strength and long life while aluminum is used in non-wearing parts for lightweight. The performance from this 37 cubic inch engine will amaze you. Standard equipment not usually found on engines this size include *Fresh Water Cooling*, *12 Volt 50 Amp Alternator*, *Prewired Electrical System*, *Self-Bleeding Fuel System* and a convenient *Oil Drain System* to eliminate messy oil changes.

The Westerbeke 13 is the youngest in Westerbeke's family of marine diesels. Ten additional engines are available from 21 to 120 hp all fresh water cooled and all built for performance, durability and economical operation . . . A true family of marine engines with standardized features and commonized parts for higher quality at lower costs.



Photo - courtesy of SABRE YACHTS



ENGINES: 10.2, 13, 21, 27, 33, 40, 52, 58, 70, 80, 100, 120

Fresh Water Cooled Diesels from Westerbeke.

A SMALL ENGINE WITH SMOOTH, QUIET, EFFICIENT POWER

WESTERBEKE 13

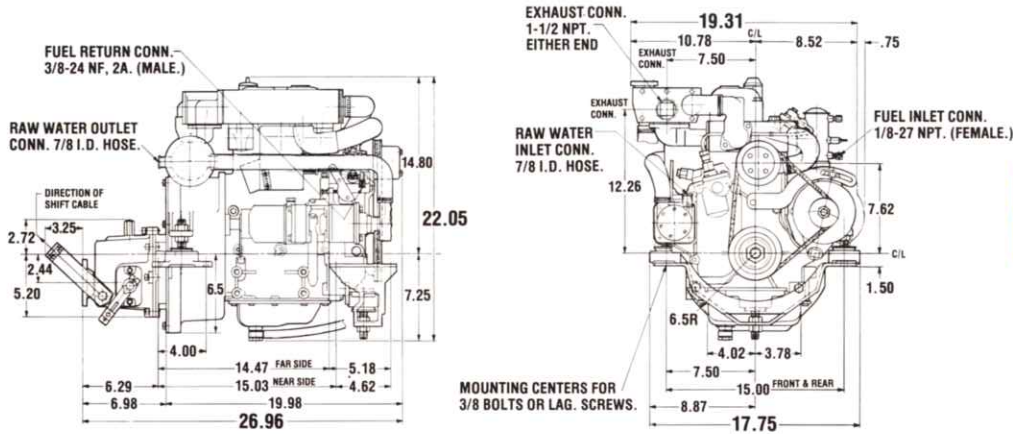

PERFORMANCE CURVES

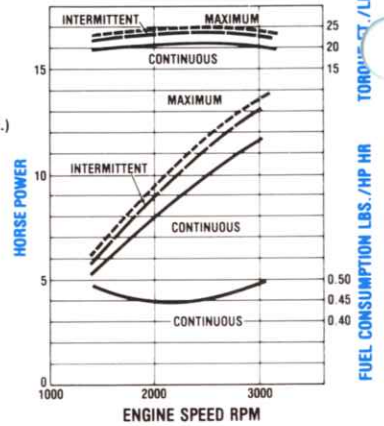

PERFORMANCE DATA

- Maximum Power Outlet 13.5/3000 RPM
- Typical Fuel Consumption Rate063 US gal/HP/hr
- Typical Fuel Consumption Rate at 2500 RPM when wheeled to turn 3000 RPM5 US gal/hr
- Capacity of Lubricant w/filter 2.8 Qts.
- Capacity of Coolant 6 Qts.

SPECIFICATIONS

- Model Number Westerbeke 13
- Engine Type 4 cycle, water cooled, naturally aspirated, vertical overhead valve, diesel engine
- Cylinder arrangement 2 cylinders in line
- Bore & Stroke 2.68"x3.07" (68mm.x78mm.)
- Displacement37 cubic inch (566 litre)
- Compression ratio 23 to 1
- No. of main bearings 2
- Rotation SAE Std. (clockwise facing front end)
- Fuel Injection Pump Bosch Distributor Type Individual plunger for each cylinder, cam driven in a precision housing machined in block for rigidity and accuracy.
- Regulator IC (built in type)
- Injectors Pintle type
- Combustion Chamber Swirl type for easy starting and quiet operation
- Firing order 1-2
- Governor Mechanical centrifugal type
- Fuel filter Paper element type
- Lubricating device Forced lubrication by trochoid pump
- lub. oil filter Full flow, spin on, paper element type
- Starting motor Geared electric motor, 12 Volt.
- Starting aid 12 Volt sheathed type glow plug
- Fuel pump Electric plunger type
- Dry weight of engine (w/trans.) 298 lbs.
- Power take-off Various crankshaft pulleys
- Propeller rotation Right hand

QUALITY CONSTRUCTION — fresh water cooling with thermostatic controls, 50 amp alternator with radio shielding, metallic water piping wherever possible for endurance, cog-type alternator belts reduce slippage, glow plug cold weather starting aid, oversized 3" diameter heat exchanger, shut-off function built into throttle control, cast iron head and block for long life.

PARTS SUPPLY — nationwide stock of parts for Westerbeke engines and generators means better service from an expanding network of stocking distributors and dealers.

EXCEPTIONAL SMOOTHNESS — 2 cylinder 4 cycle engine, high inertia flywheel, vibration isolating mounts.

SELF-BLEEDING FUEL SYSTEM — Restarts after running out of fuel without manual air bleeding.

VERY LIGHT WEIGHT — aluminum water-cooled two pass exhaust manifold and flywheel housing, save weight without sacrificing cast iron head and block.

EASE OF MAINTENANCE — removable end caps on heat exchanger for easy clean out, convenient oil drain system needs no hand pump, all wiring is led to a single 8-pin connector; heavy duty zinc anodes for heat exchanger.

EXCEPTIONAL QUIETNESS — custom designed, tuned intake silencer reduces intake air noise; modern swirl type combustion chamber design softens diesel clatter.

STANDARD EQUIPMENT

- Alarm, low oil pressure, high water temperature
- Short profile 2-1 manual transmission
- Adjustable flex isolator engine mounts (15" on centre)
- Fresh water cooling system • Coolant recovery tank
- 12 volt 50 ampere alternator • Glow plug cold weather starting aid
- Throttle, stop, and shift control brackets • Operators manual
- Engine pre-wired at the factory with a single 8 pin connector • water injected exhaust elbow • Flowcontroller — for easy connection of domestic hot water heater

OPTIONAL EQUIPMENT

- Various accessory front pulleys
- Remote mounting lube oil filter
- Hydro-Hush Muffler
- Sea Water Strainer
- Alternator Output Splitter
- Five function Electric Instrument Panel including Hour Meter and Tachometer
- Various optional transmissions
- Front exhaust outlet for Vee Drive applications



CALL YOUR WESTERBEKE REPRESENTATIVE

OR CONTACT THE...

J. H. WESTERBEKE CORP.

Avon Industrial Park, Avon, MA 02322, (617) 588-7700
 Cable: Westcorp, Avon, Telex: 92-4444



WESTERBEKE

a rugged, compact,
13 hp marine diesel

13

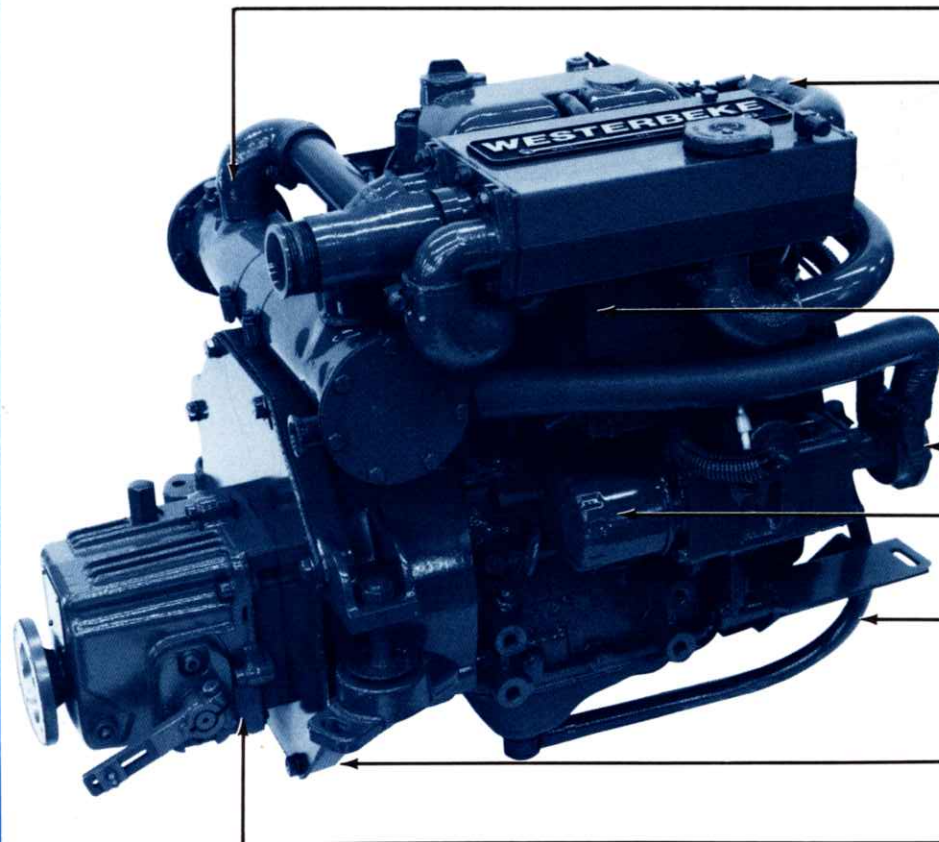

HEAT EXCHANGER WITH
HEAVY DUTY ZINC
ANODES

FRESH WATER COOLED
TWO PASS ALUMINUM
MANIFOLD THAT
INCLUDES A REMOTE
COOLANT RECOVERY
TANK FOR CONTINUOUS
MONITORING OF THE
COOLING SYSTEM

SELF-PRIMING ELECTRIC
FUEL PUMP TO ELIMINATE
BLEEDING AND HAND
PRIMING

OVERSIZED RAW WATER
PUMP

SPIN ON OIL FILTER

OIL DRAIN HOSE

ADJUSTABLE FLEX
ISOLATOR ENGINE
MOUNTS 15" ON CENTER

SHORT PROFILE TRANSMISSION

A NEW GENERATION OF MARINE ENGINES

The Westerbeke 13 provides two cylinder, four cycle smoothness in a lightweight, compact engine. Cylinder head and block are of cast iron for strength and long life while aluminum is used in non-wearing parts for lightweight. The performance from this 37 cubic inch engine will amaze you. Standard equipment not usually found on engines this size include *Fresh Water Cooling, 12 Volt 55 Amp Alternator, Prewired Electrical System, Self Priming Fuel Pump* and a convenient *Oil Drain System* to eliminate messy oil changes.

The Westerbeke 13 is the youngest in Westerbeke's family of marine diesels. Ten additional engines are available from 21 to 120 hp all fresh water cooled and all built for performance, durability and economical operation. . . A true family of marine engines with standardized features and commonized parts for higher quality at lower costs.

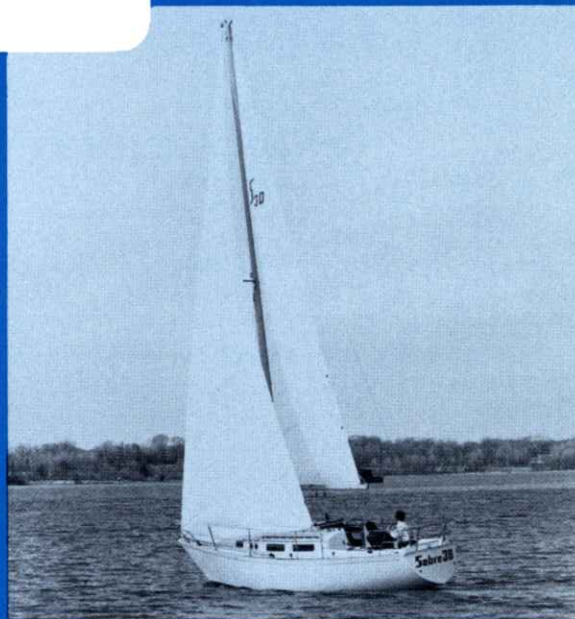

photo-courtesy of SABRE YACHTS



ENGINES: 13, 21, 27, 30, 33, 40, 50, 52, 58, 80, 120

Fresh Water Cooled Diesels from Westerbeke.

A SMALL ENGINE WITH SMOOTH, QUIET, EFFICIENT POWER

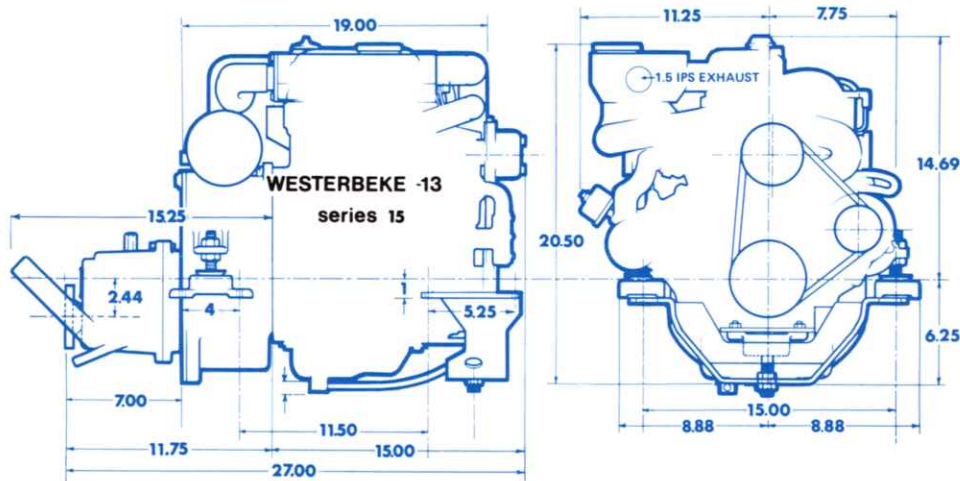

PERFORMANCE CURVES

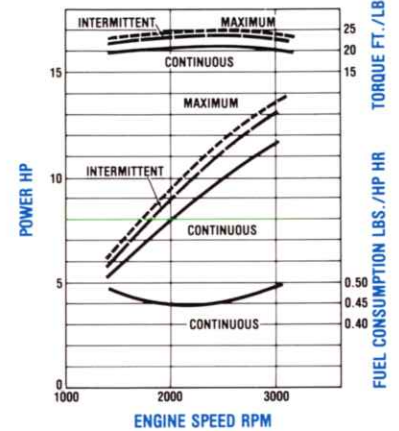

PERFORMANCE DATA

Maximum Power Outlet	13.5/3000 RPM
Specific Fuel Consumption	.45 lbs/HP-hr
Capacity of Lubricant	2.5 Qts
Capacity of Coolant	6 Qts

SPECIFICATIONS

Model Number	Westerbeke 13
Engine Type	4 cycle, water cooled, naturally aspirated, vertical overhead valve, diesel engine
Cylinder arrangement	2 cylinders in line
Bore & Stroke	2.68" x 3.07" (68mm. x 78mm.)
Displacement	.37 cubic inch (566 litre)
Compression ratio	23 to 1
No. of main bearings	2
Rotation	SAE Std. (clockwise facing front end)
Fuel Injection Pump	Bosch Distributor Type Individual plunger for each cylinder, cam driven in a precision housing machined in block for rigidity and accuracy.
Regulator	IC (built in type)
Injectors	Pintle type
Combustion Chamber	Swirl type for easy starting and quiet operation
Firing order	1-2
Governor	Mechanical centrifugal type
Fuel filter	Paper element type
Lubricating device	Forced lubrication by trochoid pump
Lub. oil filter	Full flow, spin on, paper element type
Fuel consumption	.5 GPH
Starting motor	Geared electric motor, 12 Volt.
Starting aid	12 Volt sheathed type glow plug
Fuel pump	Electric plunger type
Dry weight of engine (w/trans.)	298 lbs.
Power take-off	Various crankshaft pulleys

QUALITY CONSTRUCTION — fresh water cooling with thermostatic controls, 50 amp alternator with radio shielding, metallic water piping wherever possible for endurance, cog-type alternator belts reduce slippage, glow plug cold weather starting aid, oversized 3" diameter heat exchanger, shut-off function built into throttle control, cast iron head and block for long life.

PARTS SUPPLY — nationwide stock of parts for Westerbeke engines and generators means better service from an expanding network of stocking distributors and dealers.

EXCEPTIONAL SMOOTHNESS — 2 cylinder 4 cycle engine, high inertia flywheel, vibration isolating mounts.

NO FUEL SYSTEM BLEEDING REQUIRED — Bosch-type fuel injection system and electric fuel pump, combined with Westerbeke's self-bleeding device eliminates hand priming.

VERY LIGHT WEIGHT — aluminum water-cooled two pass exhaust manifold and flywheel housing, save weight without sacrificing cast iron head and block.

EASE OF MAINTENANCE — removable end caps on heat exchanger for easy clean out, convenient oil drain system needs no hand pump, all wiring is tinned for corrosion resistance and led to a single 8-pin connector; heavy duty zinc anodes for heat exchanger.

EXCEPTIONAL QUIETNESS — custom designed, tuned intake silencer reduces intake air noise; modern swirl type combustion chamber design softens diesel clatter.

STANDARD EQUIPMENT

Short profile 2-1 manual transmission
Adjustable flex isolator engine mounts (15" on centre)
Fresh water cooling system • Coolant recovery tank
12 volt 55 ampere alternator • Glow plug cold weather starting aid
Throttle, stop, and shift control brackets • Operators manual
Engine pre-wired at the factory with a single 8 pin connector

OPTIONAL EQUIPMENT

Various accessory front pulleys
Walter Injected Exhaust Elbow
Hydro-Hush Muffler
Sea Water Strainer
Alternator Output Splitter
Five function Electric Instrument Panel including Hour Meter and Tachometer
Various optional transmissions
Front exhaust outlet for Vee Drive applications



CALL YOUR WESTERBEKE REPRESENTATIVE

OR CONTACT THE . . .

J. H. WESTERBEKE CORP.

Avon Industrial Park, Avon, MA 02322, (617) 588-7700
Cable: Westcorp, Avon, Telex: 92-4444