

WESTERBEKE 27a

27a is Phase II
of our field proven Model 27

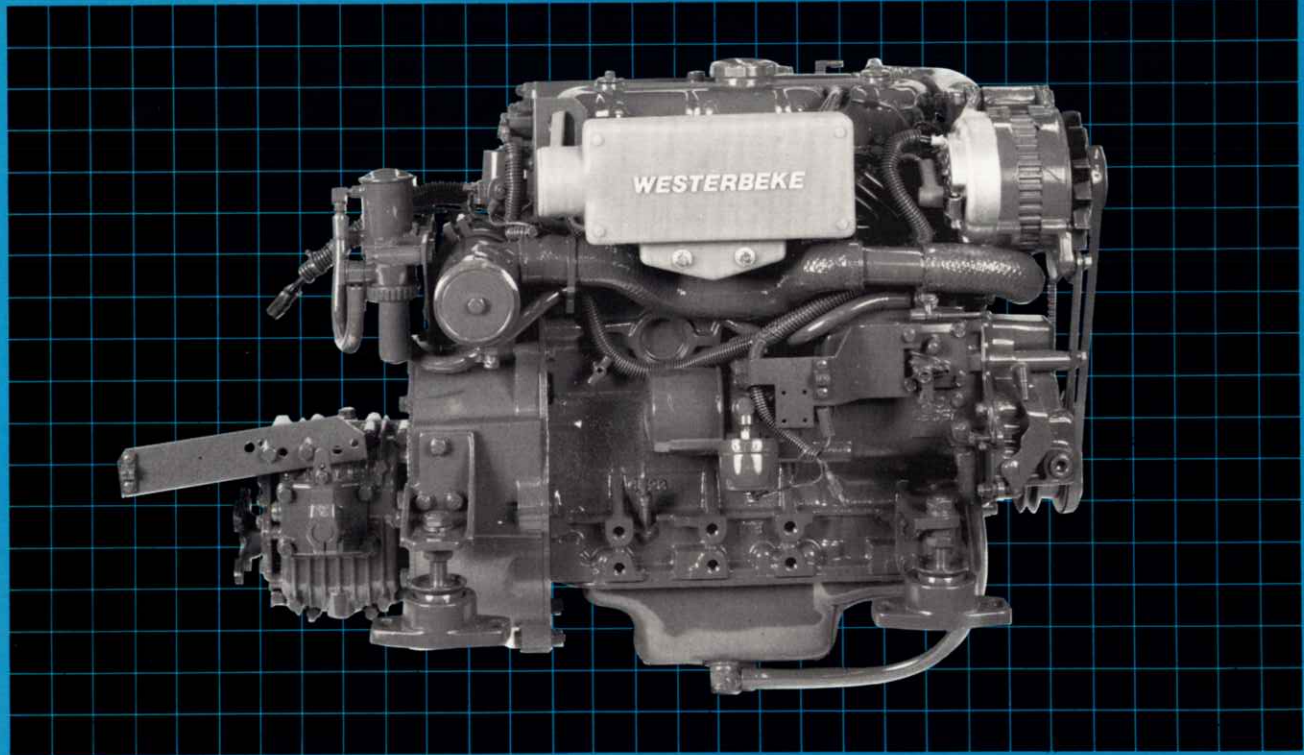

Courtesy of Hinterhoeller Yachts

WESTERBEKE 27a FEATURES

- Maximum ease of installation
- Narrow configuration
- Flywheel housing tapered for tight fits
- Four point adjustable flexible mounts
- Self priming fuel system
- Separate manual shutdown replaces combination throttle/stop
- Front and rear exhaust outlet standard
- Gear driven sea water pump

Your enjoyment and pride of ownership is assured with a Westerbeke 27a in your boat



ENGINES: 10, 13, 18, 21a, 27a, 33, 46, 52, 58, 70, 80, 100, 120

Fresh Water Cooled Diesels from Westerbeke

WESTERBEKE 27a PERFORMANCE CURVES

At Westerbeke we have always maintained a conservative policy in rating our marine engines. We have supported these figures by accurate technical graphs.

We recommend, before purchasing any engine, that you evaluate and compare the various manufacturers' power charts as they relate to horsepower, particularly in the R.P.M.s in which you expect to operate.

The Westerbeke 27a with 80 cubic inch displacement, develops usable horsepower of 20 hp @ 2000 RPM and 30 hp @ 3000 RPM. Remember, displacement and horsepower are proportional!

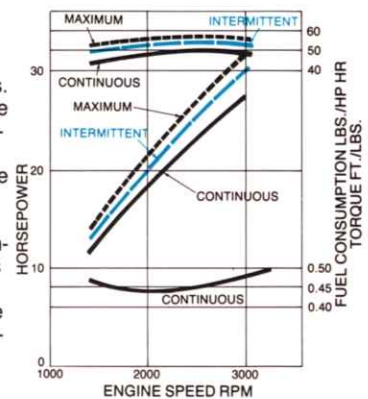

INSTALLATION COMPARISON CHART

In Inches and Lbs. *W/Transmission

Engine Model	displ.	*length	height	width	*weight
YANMAR 3 HMF	59 C.I.	31.1	24.1	18.1	368
UNIVERSAL 30	68 C.I.	31.5	24.4	19.9	425
WESTERBEKE 27a	80 C.I.	32.62	22.68	16.85	424

A small light 4 cylinder 4 cycle marine diesel engine

WESTERBEKE 27a

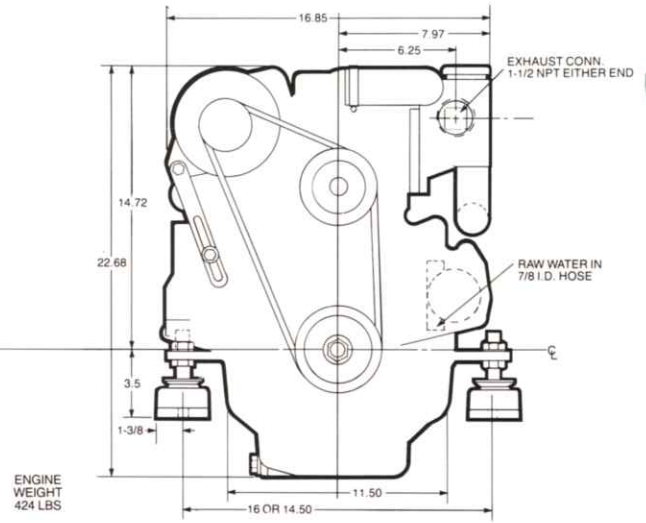
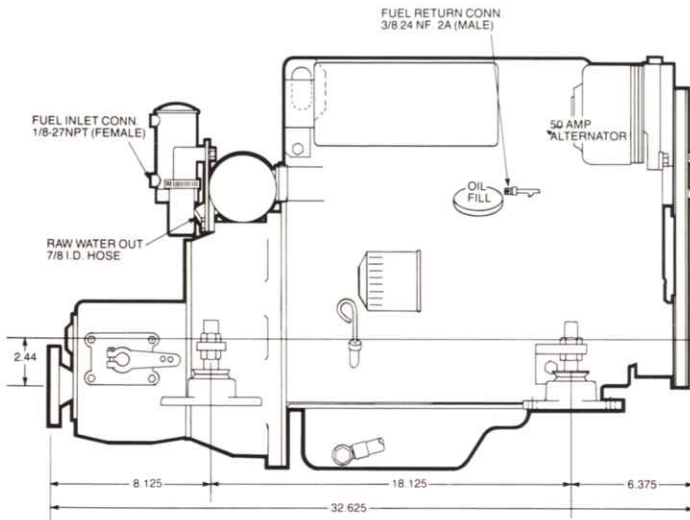

Specifications

Model Number Westerbeke 27a
 Engine Type 4 cyl., 4 cycle, water cooled diesel
 Bore and Stroke 2.87" x 3.07" (73mm x 78mm)
 Displacement 80 cubic inch (1.3 Litre)
 Compression Ratio 23 to 1
 Number of Main Bearings 5
 Fuel Injection Pump Bosch individual plunger type
 Injectors Pintle type
 Combustion Chamber Swirl type for easy starting and quiet operation
 Starting Motor 12 Volt, geared type
 Fuel Lift Pump Electric plunger type
 Dry Weight of Engine (w/Transmission) 424 lbs.

Standard Equipment

- Short profile 2:1 manual transmission
 - Propeller shaft coupling bored to size
 - Adjustable flex mounts (14.59 or 16 inch centers)
 - Fresh water cooling system
 - Coolant recovery tank
 - 12 volt 50 ampere alternator
 - Glow plug cold starting aid
 - Throttle, stop, and shift control brackets
 - Engine prewired to single 8 pin connector
 - Flow control for domestic hot water connection
 - Water injected exhaust elbow
 - 15' connector, engine to instrument panel
 - Operator's manual
 - Deluxe multi-function electric instrument panel
- Includes hour meter, tachometer, water temperature and oil pressure gauges, battery voltmeter, key switch, preheat and start buttons



Optional Equipment

- Remote mounting lube filters
- Alternator output splitter
- Sea water intake strainer
- Hydro-Hush B waterlift exhaust silencer

Performance Data

Maximum Power Output 30 HP/3000 RPM
 Typical Fuel Consumption Rate 0.63 US gal/HP/hr
 Typical Fuel Consumption Rate at 2500 RPM
 When Wheeled to Turn 3000 RPM 1.0 US gal/hr
 Capacity of Lubricant 4 Qts
 Capacity of Coolant 8½ Qts

HYDRO-HUSH B EXHAUST SYSTEM (optional)

HYDRO-HUSH B SILENCER
 Siphon break
 Coupling
 Straight
 45°
 90°

A complete exhaust system can be assembled using the Westerbeke Hydro-Hush B waterlift exhaust silencer with various adapting connectors and couplings, and a supply of 1-7/8" I.D. exhaust hose.

Typical HYDRO-HUSH B installation

Call your Westerbeke representative

or contact the ...



J. H. WESTERBEKE CORP.

AVON INDUSTRIAL PARK, AVON, MA 02322-0181 • (617) 588-7700
 CABLE: WESTCORP, AVON • TELEX: 92-4444