

# WESTERBEKE 45 KW MARINE DIESEL GENERATOR SET



Broward 110' Raised-Bridge Motor Yacht

A reliable, smooth running generator set for all your ship-board needs. 120/240 volt electrical power at the turn of a switch for electric cooking, air conditioning, refrigeration, cabin appliances and navigation equipment. Like all Westerbeke generator sets, it is fresh water cooled with an engine mounted heat exchanger. The engine and single bearing generator form a compact, carefully aligned generator set. The complete unit is mounted to a fabricated base through flexible isolator mounts that prevent transfer of vibration. A removable drip tray is fitted under the engine.

The Westerbeke 45 is safe, dependable, durable and economical to operate. At 1800 RPM, it offers 6 cylinder, 4 cycle smoothness for complete electric living on board.

**FUEL ECONOMY AND LONGEVITY  
FOR FINE YACHT OR WORKBOAT**

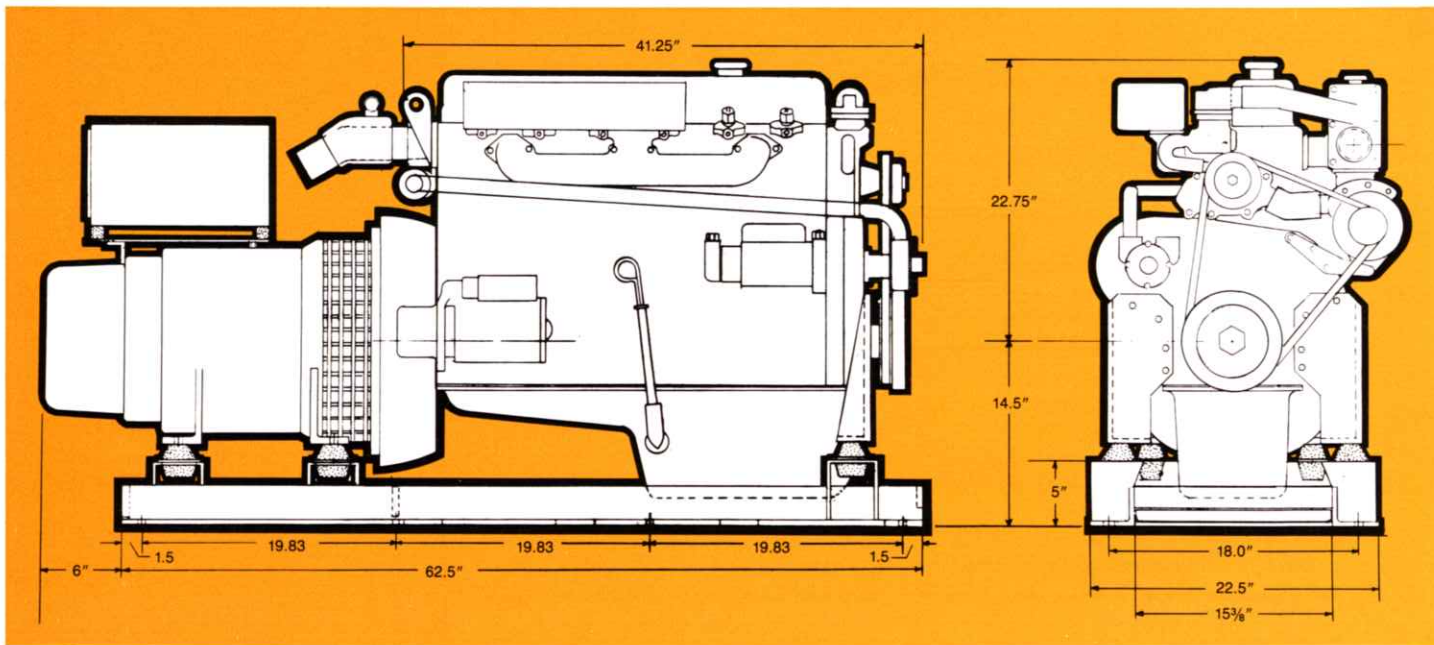

### RECONNECTIBLE BRUSHLESS ALTERNATORS

MODEL	ELECTRICAL CHARACTERISTICS					RATINGS		DERATINGS	ENGINE	
	VOLTS	AMPS	HERTZ	PHASE	WIRE	KW	P.F.		R.P.M.	START
WLF-45-614	120/240	375/187	60	1	3 <sup>1</sup>	45	1.0	3.5% for each 1000 feet above sea level.	1800	REMOTE
WLF-45-634	120/240	135	60	3	4	45	1.0		1800	REMOTE
WLF-36-514	120/240	300/150	50	1	3 <sup>1</sup>	36	1.0	1% for each 10°F above 85°F ambient.	1500	REMOTE
WLF-36-534	120/240	108	50	3	4	36	1.0		1500	REMOTE
WLF-45-614 <sup>2</sup>	120/240	468/234	60	1	3 <sup>2</sup>	45	.8	10% for Continuous Duty	1800	REMOTE

<sup>1</sup> 4 LEAD RECONNECTIBLE TO FULL OUTPUT AT 120 VOLTS

<sup>2</sup> 12 LEAD RECONNECTIBLE VARIOUS VOLTAGES TO 480



**GENERATORS: 3, 4.4, 6, 8, 8g, 11, 12.5, 15, 20, 25, 32, 45 kw's**

**Fresh Water Cooled Diesel and Gasoline Generators from Westerbeke.**

# WESTERBEKE 45 KW MARINE DIESEL GENERATOR

**WESTERBEKE 45 KW**

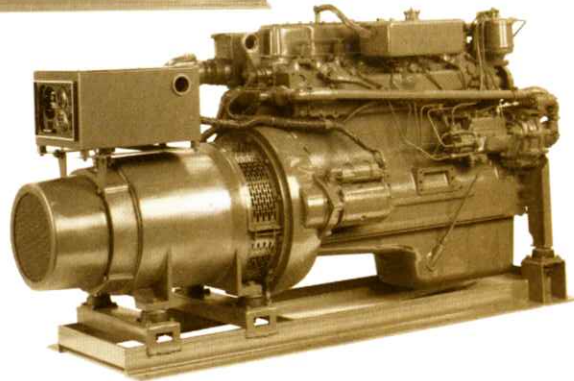
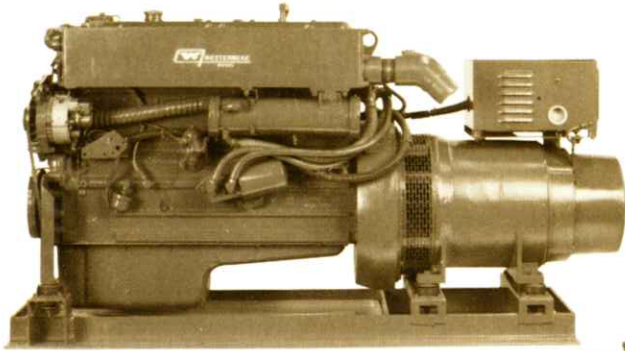

## FEATURES

### ENGINE

Type . . . . . 6 Cylinder, 4 Cycle, Naturally Aspirated, Direct Injection Diesel  
 Displacement . . . . . 345.3 Cubic Inches  
 Power . . . . . 90 H.P. @ 1800 RPM  
 Block . . . . . Cast Mono Block with Wet Liners  
 Head . . . . . Cast Iron with Renewable Valve Guides  
 Crankshaft: . . . . . 7 Main Bearings, Statically and Dynamically Balanced  
 Timing . . . . . By Hardened and Ground Helical Gears  
 Fuel System . . . . . Distribution Type Injection Pump with Mechanical Governor  
 Cooling . . . . . Fresh Water by Heat Exchanger  
 Electric System . . . . . 12 Volt Starter and 51 Ampere Battery Charging Alternator

### ALTERNATOR

Single Bearing Construction  
 Brushless Design  
 Exciter Mounted Outboard of Bearing for Easy Field Exchange  
 Cast Aluminum Frame for Light Weight  
 Voltage Regulated to  $\pm 2\%$   
 Engine Instruments, Voltage Regulator, Field Circuit Breaker, and Connection Block are Mounted on top of Alternator for Easy Access

### STANDARD EQUIPMENT

Assembled unit as shown complete with substantial fabricated base, removable plastic drip tray, flexible rubber mounts, water injected exhaust elbow, high temperature/low oil pressure shut down, wiring diagram and operators manual.

### OPTIONAL EQUIPMENT

- Remote Instrument Panel
- 15' Cable for Remote Panel
- Ship Shore Transfer Switch

CALL YOUR WESTERBEKE REPRESENTATIVE

OR CONTACT THE . . .

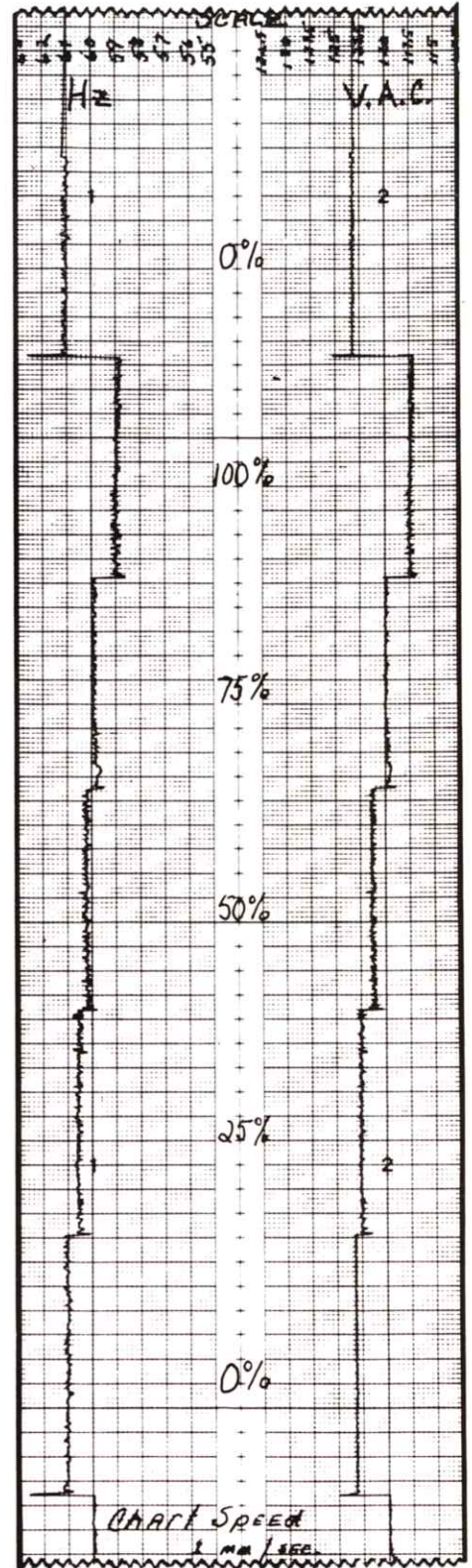

Typical output chart as recorded on every Westerbeke Diesel Generator with electronic solid state regulation.



WESTERBEKE CORPORATION  
 AVON INDUSTRIAL PARK, AVON, MA 02322 • TEL: (508) 588-7700