

Available fully networked to NMEA 2000®

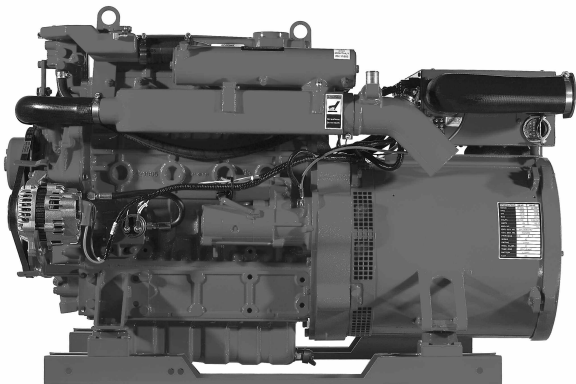

33.0/26.0 EDEA Marine Diesel Generator

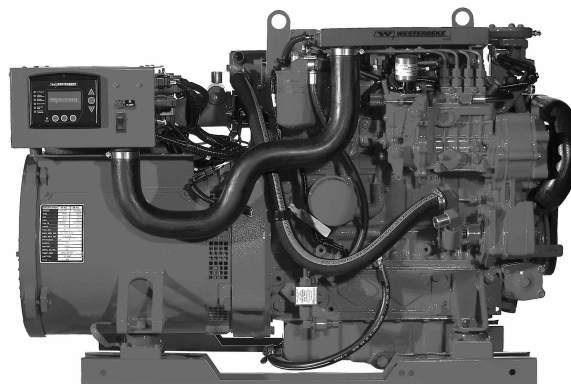

33.0/26.0 EDEA Marine Diesel Generator

The First Electronic Diesel Generators Available NMEA 2000® Certified

Westerbeke, the **first** company to bring constant speed **EFI** generators and **Safe-CO™** generators to the marine market, introduces another first. The wave of the future, Westerbeke D-NET™ electronic generators are offered with standard Westerlink™ or optional NMEA 2000® compliant databus communication. NMEA 2000® is a network for shipboard communications developed under National Marine Electronics Association (NMEA) standards. NMEA 2000® generators, combined with other certified components, allow boat builders and their customers to significantly reduce the cost, weight and space normally required to run cables throughout the vessel. All certified components freely communicate and are linked to just one NMEA 2000® cable using "T" connections that simplify networking.

Information At Your Fingertips

All Westerbeke D-NET™ generators have available digital controls offering simplified and easy to understand information on operational status and, if necessary, system diagnostics. Westerbeke also features "at a glance" illuminated lights indicating proper operation. They monitor battery voltage, generator voltage, generator frequency, oil pressure, coolant and exhaust temperature. All this information may be viewed from a distance—all green lights indicate referenced systems are functioning properly. Further details are available on the screen display. The user may conveniently scroll for operational or diagnostic information without encountering "codes". Westerbeke uses text so the user does not have to refer to a manual to decipher numeric information.

Quiet, Slow-Speed Digital Operation

Operating at 1800-rpm with a newly designed, tuned air intake system and 4-cylinder engine, the 33.0 EDEA generator runs smooth and quiet. Augmenting this desired effect is the electronic governing that virtually eliminates "droop" when load is applied. Include the optional Sound Guard SST with high quality stainless steel base and frame with stylish powder coated aluminum panels and you have a generator as attractive as it is quiet.

Standard Features

- Digital display and diagnostics panel
- Electronic governing
- Electronic voltage regulation
- Safety shut-downs: overspeed, underspeed, low oil pressure, high exhaust and high coolant temperature
- Field breaker
- 60 amp battery charging alternator
- Power take-off interface
- Fresh water cooling and coolant recovery tank
- 45 degree water injected exhaust elbow
- Belt driven raw water pump
- Tuned air intake system
- Anti-vibration mounts – fail safe rubber type
- Lube oil drain hose and drip tray
- Oil fill – top and side
- Belt guard
- Operators' Manual and parts list
- 5-year limited warranty

Digital Display

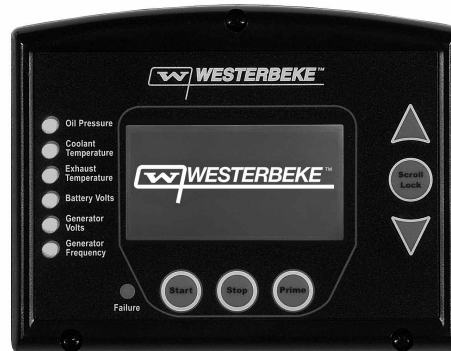

Generator Design

DESIGN: Brushless, four pole, revolving, power take-off.
VOLTAGE REGULATION: Standard +/- 2% no load to full load.
FREQUENCY REGULATION: .3 Hz (.5%) no load to full load.
INSULATION: Class "H", as defined by NEMA MG1-1.65.

TEMPERATURE RISE: Within NEMA MG1-22.40 definition when operating at full load.
COOLING: Cast centrifugal blower, direct connected.
ELECTROMAGNETIC INTERFERENCE LEVEL: Exceeds requirements for most marine radio-telephones and standard TVs.

Model	Electrical Characteristics					Ratings		Engine	
	Volts	Amps	Hertz	Phase	Wire	Power Factor	KW	RPM	Start
33.0 EDEA-6112*	120/240	275/137.5	60	1	12	1.0	33.0	1800	Remote
26.0 EDEA-5112*	230	113	50	1	12	1.0	26.0	1500	Remote

* Adjustable to 50 or 60 Hertz. Three phase units available in these ratings.

Specifications

Number of cylinders	4 Cylinder vertical in-line	
Type	4 cycle	
Displacement	220.9 cu. in. (3.62 liter)	
Bore and stroke	3.86" x 4.72" (98.0 mm x 120.0 mm)	
Compression ratio	23:1	
Rated rpm	1800@60Hz /1500@50Hz	
HP @ 1800/1500 rpm	52/41	
Maximum angle of operation	Not to exceed 20° in all directions	
Exhaust elbow connection	3" OD (76.2mm)	
Sea water connection	1" OD (25.4mm)	
Dry weight	1,135 lbs. (515.9 kilos)	
Combustion system	Indirect injection	
Aspiration	Naturally aspirated	
Lubrication system	Forced lubrication by gear pump	
Cooling system	16 quarts (15.14 liters)	
Starting aid	12 volt sheathed type glow plug	
Fuel consumption (approx.)	1800 rpm	1500 rpm
100% load GPH (LPH)	2.89 (10.9)	2.23 (8.4)
75% load GPH (LPH)	2.16 (8.2)	1.67 (6.3)
50% load GPH (LPH)	1.58 (6.0)	1.25 (4.7)
25% load GPH (LPH)	1.09 (4.1)	0.88 (3.3)
Fuel injection pump	Bosch type mini pump	
Governor	Electronic	
Injectors	Bosch type	
Fuel Filter	Full flow, replaceable element	
Fuel transfer pump	12 volt electric type	
Fuel supply and return piping	1/4" ID (6.35 mm) minimum 3/8" ID (9.53 mm) maximum	

Lube oil filter	Full flow, spin-on element
Lubricant capacity (incl. filter)	14 quarts (13.3 liters)
Starting motor	12 volt, solenoid, actuated shift
Alternator	60 amps
Cold cranking amps	400-600 amps (includes heater)
Electrical system	12 volts DC, negative ground

Construction – Engine Components

Cylinder head	Cast Iron
Cylinder block	Cast Iron
Crankshaft	Forged crankshaft, five main bearings
Valves	Overhead valves
Fuel System	"EZ-Bleed"
Intake system	Tuned intake system for maximum noise reduction
Cooling system	Fresh water-cooled with heat exchanger
Exhaust manifold	Cast aluminum, fresh water-cooled

Optional Equipment

- NMEA 2000® compliant databus communication
- Remote digital display (NMEA 2000®)
- Remote digital display (Westerlink™)
- Remote start/stop for use with Westerlink™ or NMEA 2000® version
- Sound Guard SST
- Hydro-hush muffler and fittings; fuel water separator
- Anti-siphon valve with 1" inch stainless steel loop
- Ship-to-shore switch
- "A" on board spare parts kit; "B" extended cruising spare parts kit
- Power take-off with electric clutch
- Technical manual
- Generator set available painted white upon request (standard red)

Dimensions

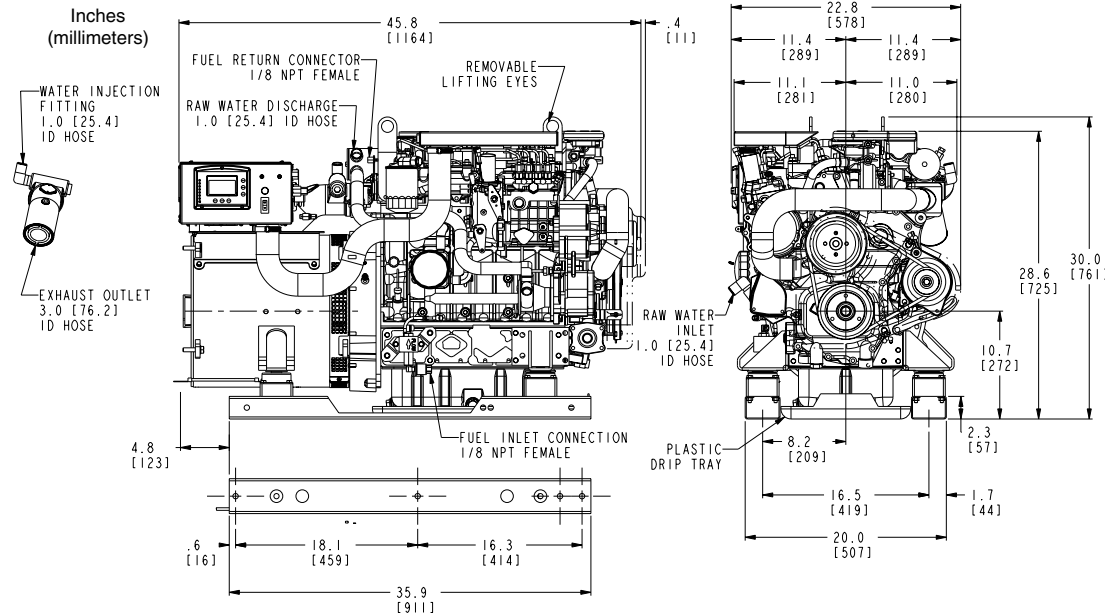

Optional Sound Guard SST PN 53070

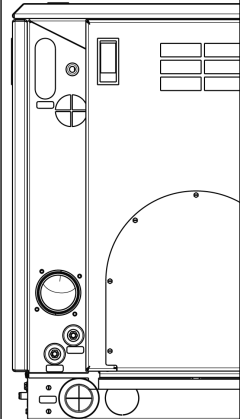

SST
 Length: 50.8" (1291mm)
 Width: 27.2" (691mm)
 Height: 30.8" (782mm)
 Weight: 150 lbs. (68kg)