



**GASOLINE
GENERATOR**

**6.5 SBCG 60Hz
5.4 SBCG 50Hz**

Ultra-Low Carbon Monoxide Emissions

Carbon Monoxide Cut more than **99%**

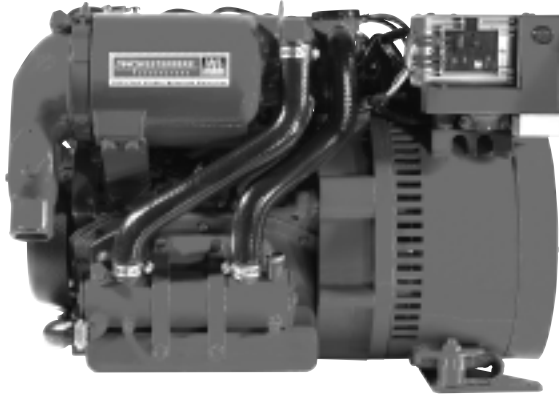

6.5 SBCG Marine Gasoline Generator

The First Low CO Generators

Westerbeke, the first company to bring constant speed **EFI** generators to the marine market introduces another **first: low carbon monoxide** generators. The new Safe-CO™ series gasoline generators have cut carbon monoxide emissions by more than 99 percent!

EFI and Electronic Speed Control

All Safe-CO™ model generators feature electronic fuel injection (EFI). EFI provides optimum fuel efficiency, easy starting and improved reliability. In conjunction with EFI, electronic speed control (via electronic governor) maintains the engine at a constant speed (precise frequency regulation) and eliminates “bogging down” when load is applied.

Smooth, Quiet & Compact

The 6.5 SBCG not only has one of the smallest envelopes available for a 6.5 kW marine gasoline generator, but there is not another generator like it. Operating with 3-cylinders and a balance shaft that virtually eliminates vibration, the 6.5 SBCG is an extremely smooth running 6.5 kW. The unit also operates at a quiet, electronically controlled, 1800-rpm. **So quiet, it doesn't require a sound shield. No other generator in its class is quieter!**

Durable and Reliable

The 6.5 SBCG uses a heavy duty industrial base engine for long lasting service. The unit also operates at 28% of its maximum engine speed, so the owner can expect more durability and reliability compared with competing 3600-rpm units running near maximum engine speed.

Westerbeke Safe-CO™ gensets are designed to operate in extreme ambient temperatures and incorporate a returnless fuel system to help eliminate fuel vapor-lock.



6.5 SBCG Marine Gasoline Generator

Full Torque, Power Take-Off Interface

A customer sourced, electric clutch and hydraulic pump can be mounted to the full torque, power take-off interface for use with such items as bow or stern thrusters, compressors, winches and “emergency get-home” systems.

Five Year Limited Warranty

The 6.5 SBCG is backed by Westerbeke's 5-year limited warranty. The presence of Westerbeke in over 65 countries around the world provides customers with easy access to parts, service and technical support worldwide. Established in 1937, Westerbeke is committed to providing its customers with quality products and unequalled after sales support.

Standard Features

- Simple, “one-touch” start/stop control panel with running hour meter and LED lights
- Electronic fuel injection
- Returnless fuel system
- Electronic governing
- Safety shut-downs—overspeed, low oil pressure, high exhaust temperature
- Fresh water cooling and coolant recovery tank
- Field convertible to 50 or 60Hz
- A.C. circuit breaker
- 17 amp battery charger
- 90° water injected exhaust elbow
- Belt-driven, raw water pump
- Vibration isolators
- Lube oil drain hose
- Belt guard
- Operators' manual and parts list
- CARB & EPA certified
- Meets U.S.C.G. regulation 33CFR-183



WESTERBEKE
GASOLINE
GENERATOR

**6.5 SBCG 60Hz
5.4 SBCG 50Hz**

Generator Design

DESIGN: Brushless, four pole, revolving field.
VOLTAGE REGULATION: Standard +/- 5% no load to full load.
FREQUENCY REGULATION: .5 Hz (1%) no load to full load.
INSULATION: Class "H" as defined by NEMA MG1-1.66.

TEMPERATURE RISE: Within NEMA MG1-22.40 operating at full load.
COOLING: Cast centrifugal blower, direct connected.
ELECTROMAGNETIC INTERFERENCE LEVEL: Exceeds requirements for most marine radio-telephones and standard TV's.

Model	Electrical Characteristics				Ratings			Engine	
	Volts	Amps	Hertz	Phase	Wire	Power Factor	kW	RPM	Start
6.5 SBCGC-614	120	54.1	60	1	4	1.0	6.5	1800	Remote
5.4 SBCGC-514	230	23.4	50	1	4	1.0	5.4	1500	Remote

Specifications

Number of Cylinders	3 cylinder, vertical in-line
Type	4 cycle
Displacement	40.3 cu. in. (.66 liter)
Bore and stroke	2.56" x 2.61" (65.0mm x 66.3mm)
Compression ratio	9.8:1
Rated RPM	60 Hz-1800 rpm 50 Hz-1500 rpm
HP @ 1800/1500 rpm	10.0/8.5 HP
Maximum angle of operation	Not to exceed 25° in all directions
Exhaust elbow conn.	2.0" OD (50.8mm)
Raw water conn.	1.0" OD (25.4mm)
Dry weight	381 lbs (172.8 kg)
Combustion system	Semi-spherical type
Aspiration	Naturally aspirated
Lubrication system	Forced pump
Cooling system	3.5 quarts (3.3 liter)
Full load fuel consumption	.7 GPH (2.6 LPH) @ 1800 rpm .6 GPH (2.3 LPH) @ 1500 rpm
Governor	Electronic
Lube oil filter	Full flow, spin on element
Lubricant capacity	3.0 quarts (2.8 liters)

Fuel transfer pump	Electric type
Fuel supply	.25" ID (6.35mm)
Starting motor	12 volt, 1.4kW
Battery charging	17 amps, integral electric type
Cold cranking amps	105 amps @ 70 degrees F
Electrical system	12 volts DC, negative ground

Construction – Engine Components

Cylinder head	Aluminum
Cylinder block	Cast iron
Crankshaft	Forged crankshaft, four main bearings
Valves	Overhead, rotating type
Fuel system	Throttle body E.F.I.
Cooling system	Fresh water-cooled with heat exchanger
Exhaust manifold	Cast aluminum, fresh water-cooled

Optional Equipment

Remote start-stop panel
Ship-shore switch
Hydro-hush muffler and fittings
"A" on-board spare parts kit; "B" extended cruising spare parts kit
Anti-siphon valve for overboard cooling water discharge
Technical manual

Basic Dimensions inches (millimeters)

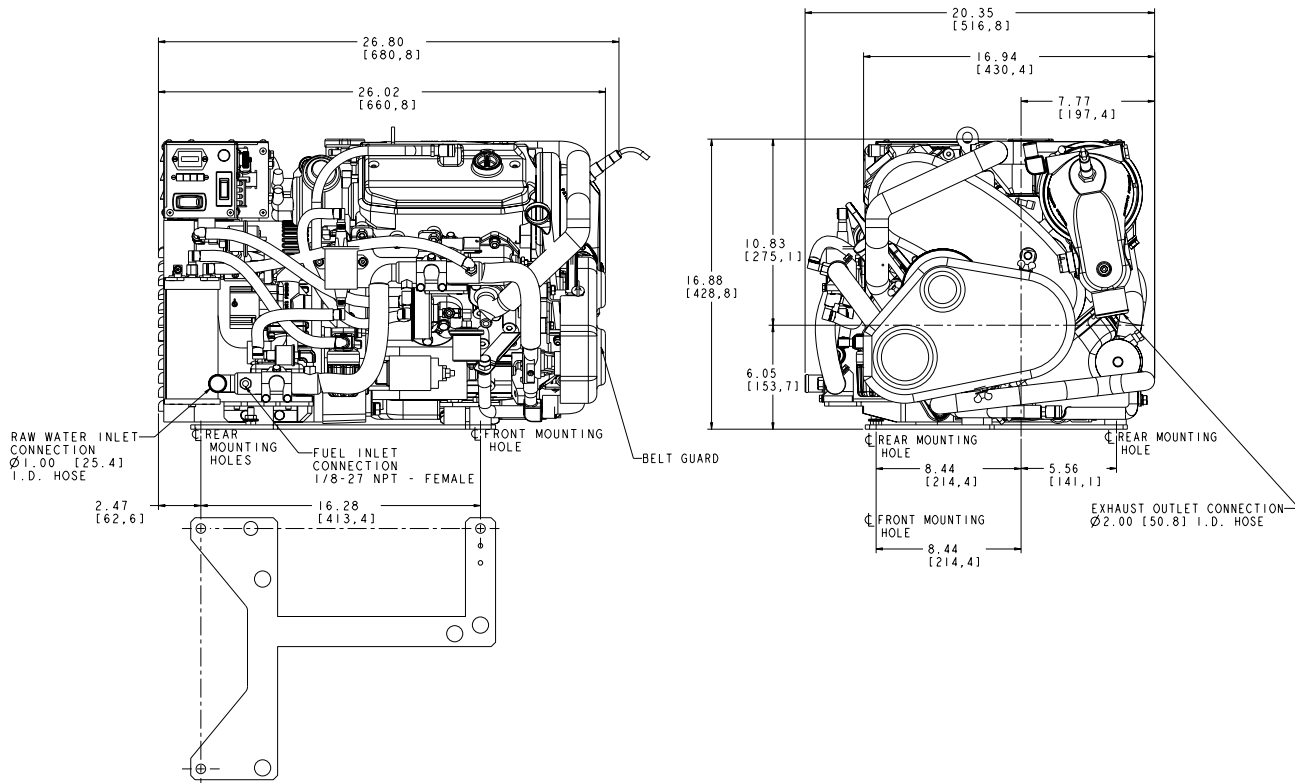

Drawings are for reference only and should not be used for installation. Detailed installation drawings are available upon request.