



**GASOLINE
GENERATORS**

**Houseboat
Series**

Ultra-Low Carbon Monoxide Emissions

Carbon Monoxide Cut more than **99%**

The First Low CO Generators

Westerbeke, the first company to bring constant speed **EFI** generators to the marine market introduces the **first low carbon monoxide** series generators. The new Safe-CO™ gasoline “houseboat series” generators cut carbon monoxide emissions by more than 99 percent. Now you can breathe easy!

EFI & Electronic Speed Control

All Safe-CO™ model generators feature electronic fuel injection (EFI). EFI provides optimum fuel efficiency, easy starting and improved reliability. In conjunction with EFI, electronic speed control (via electronic governor) maintains the engine at a constant speed (precise frequency regulation) and eliminates “bogging down” when load is applied.

Smooth & Quiet

Houseboat series generators operate at a quiet, electronically controlled, 1800-rpm. Powered by 4-cylinder, 4-stroke engines that virtually eliminate vibration, the houseboat series gasoline generators are also extremely smooth running.

Durable and Reliable

These modern overhead cam engines operate at a slow 1800-rpm for long life and low maintenance. The houseboat series owner can expect more durability and reliability from his slow speed Westerbeke generator set. Customers can also rely on Westerbeke’s stellar reputation in the houseboat industry from Lake Powell, U.S.A. to Lake Eildon, Australia.

Westerbeke Safe-CO™ gensets are designed to operate in extreme ambient temperatures and incorporate a returnless fuel system to help eliminate fuel vapor-lock.

Five Year Limited Warranty

Houseboat series generators are backed by Westerbeke’s 5-year limited warranty. The presence of Westerbeke in over 65 countries around the world provides customers with easy access to parts, service and technical support worldwide. Established in 1937, Westerbeke is committed to providing its customers with quality products and unequalled after sales support.

Full Torque Power Take-Off

An optional PTO, back-end mounted for full torque power take-off, is available.

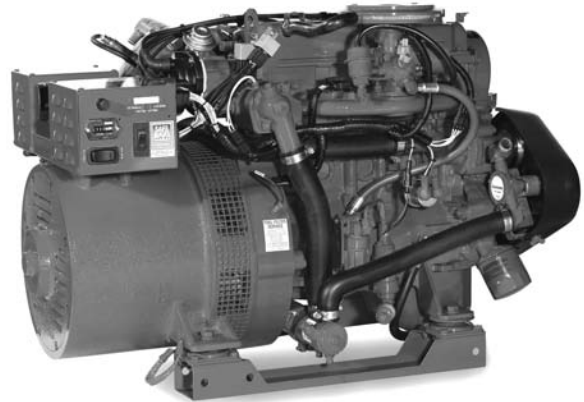

8 kW – 22.5 kW at 60Hz (6.4 kW – 18.7 kW at 50Hz)

Standard Features

- Simple, “one-touch” start/stop control panel with running hour meter and LED lights
- Electronic fuel injection
- Returnless fuel system
- Electronic governing
- Electronic voltage regulation
- Safety shut-downs—overspeed, low oil pressure, high exhaust temperature
- Fresh water cooling and coolant recovery tank
- Field convertible to 50 or 60 Hz
- A.C. circuit breaker
- 50 amp battery charging alternator
- Water injected exhaust elbow
- Belt-driven raw water pump
- Vibration isolators
- Lube oil drain hose
- Belt guard
- Operators’ manual and parts list
- EPA & CARB certified
- Meets U.S.C.G regulation 33CFR-183

Generator Design

DESIGN: Brushless, four pole, revolving field, power take-off
VOLTAGE REGULATION: Standard +/- 2% no load to full load
FREQUENCY REGULATION: .5 Hz (1%) no load to full load
INSULATION: Class "H" as defined by NEMA MG1-1.66

TEMPERATURE RISE: Within NEMA MG1-22.40 operating at full load
COOLING: Cast centrifugal blower, direct connected
ELECTROMAGNETIC INTERFERENCE LEVEL: Exceeds requirements for most marine radio-telephones and standard TVs

Model (60 Hz & 50 Hz)	ELECTRICAL CHARACTERISTICS					RATINGS		ENGINE
	Volts	Amps	Hertz	Phase	Wire	P.F.	KW	RPM
8.0 SBEG	120/240	66/33	60	1	4	1.0	8.0	1800
10.0 SBEG	120/240	83/41	60	1	4	1.0	10.0	1800
12.5 SBEG	120/240	104/52	60	1	4	1.0	12.5	1800
14.0 SBEG	120/240	116/58	60	1	4	1.0	14.0	1800
20.0 SBEGA	120/240	166/83	60	1	4	1.0	20.0	1800
22.5 SBEGA	120/240	187/93	60	1	4	1.0	22.5	1800
6.4 SBEG	230	27	50	1	4	1.0	6.4	1500
8.0 SBEG	230	34	50	1	4	1.0	8.0	1500
10.0 SBEG	230	43	50	1	4	1.0	10.0	1500
11.6 SBEG	230	50	50	1	4	1.0	11.6	1500
16.0 SBEGA	230	69	50	1	4	1.0	16.0	1500
18.7 SBEGA	230	81	50	1	4	1.0	18.7	1500

SPECIFICATIONS (60 Hz & 50 Hz)	MODEL (60 HZ)					
	8.0 SBEG	10.0 SBEG	12.5 SBEG	14.0 SBEG	20.0 SBEGA	22.5 SBEGA
Number of Cylinders	4	4	4	4	4	4
Type	4 Cycle	4 Cycle	4 Cycle	4 Cycle	4 Cycle	4 Cycle
Displacement – Cubic Inches	89.6	89.6	89.6	89.6	133.3	133.3
Cylinder Bore & Stroke – Inches	2.97x3.23	2.97x3.23	2.97x3.23	2.97x3.23	3.38x3.70	3.38x3.70
Horsepower at 1800/1500 RPM	24/19	24/19	24/19	24/19	35/28	35/28
Exhaust Elbow Connection – Inches	3.0	3.0	3.0	3.0	3.0	3.0
Raw Water Connection – Inches	1.0	1.0	1.0	1.0	1.0	1.0
Cooling System Capacity – Quarts	6.0	6.0	6.0	6.0	9.5	9.5
Lube Oil Capacity – Quarts	3.5	3.5	3.5	3.5	4.5	4.5
Charging Alternator – Amps	50	50	50	50	50	50
Cold Cranking Amps – Amps	150	150	150	150	250	250
Electrical System – Neg. Gnd. – Volts	12	12	12	12	12	12
Approx. Full Load Fuel Consumption – GPH (1800 RPM)	1.0	1.1	1.3	1.4	2.0	2.2
Approx. Full Load Fuel Consumption – LPH (1500 RPM)	3.0	3.5	4.0	4.5	6.3	7.0

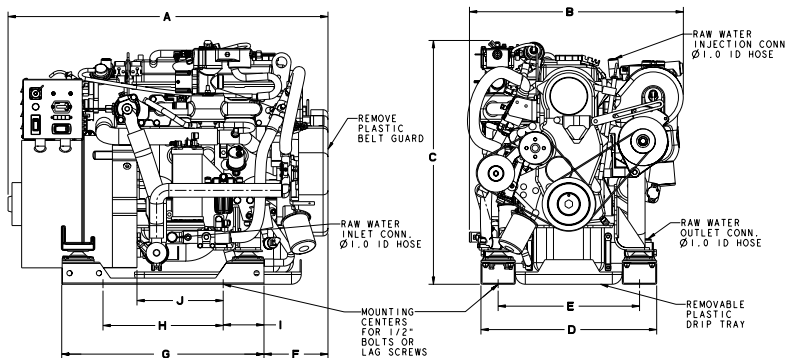

Optional Equipment

- Remote Start-Stop Panel
- Ship-Shore Transfer Switch
- Hydro-Hush Muffler
- Anti-siphon Valve
- Technical Manual
- "A" & "B" On-board Spare Parts Kit

Note: Generators require 3" I.D. exhaust outlet.

Model (60 Hz)	Dry Weight	DIMENSIONS – INCHES									
		A	B	C	D	E	F	G	H	I	J
8.0 SBEG	438 lbs.	32.6	21.8	25.1	17.9	14.4	6.5	20.6	12.3	4.2	NA
10.0 SBEG	463 lbs.	33.8	21.8	25.1	17.9	14.4	6.5	20.6	12.3	4.2	NA
12.5 SBEG	495 lbs.	34.8	21.8	25.1	17.9	14.4	6.5	20.6	12.3	4.2	NA
14.0 SBEG	522 lbs.	36.6	21.8	25.1	17.9	14.4	6.5	20.6	12.3	4.2	NA
20.0 SBEGA	741 lbs.	42.3	24.3	27.9	20.0	16.5	6.0	27.5	20.3	4.1	10.2
22.5 SBEGA	771 lbs.	42.3	24.3	27.9	20.0	16.5	6.0	27.6	20.3	4.1	10.2

Drawings are for reference only and should not be used for installation. Detailed installation drawings are available upon request.