

SERVICE BULLETIN

DATE: September 14, 2011

BULLETIN NUMBER:

263

SUBJECT: Capacitor change required when converting between 50 and 60 HZ.

MODELS AFFECTED: 5.4/6.5 SBCG (Safe-CO®) and 5.8/7.0 BCGD (carbureted)

DETAIL: 5.4/6.5 SBCG products built after manufacturing date code E802 (February 2008) and all 5.8/7.0 BCGD products are field convertible between 50 and 60 HZ.

The capacitor is different depending on the hertz. The capacitors **MUST** be changed to insure proper voltage output.

Please follow the conversion guidelines found in the respective Operator's Manual making sure to change the output wiring and engine speed accordingly.

Standard 60 hertz capacitors are 35 MF, part number 49627. For 50 hertz use 40 MF, part number 46639.

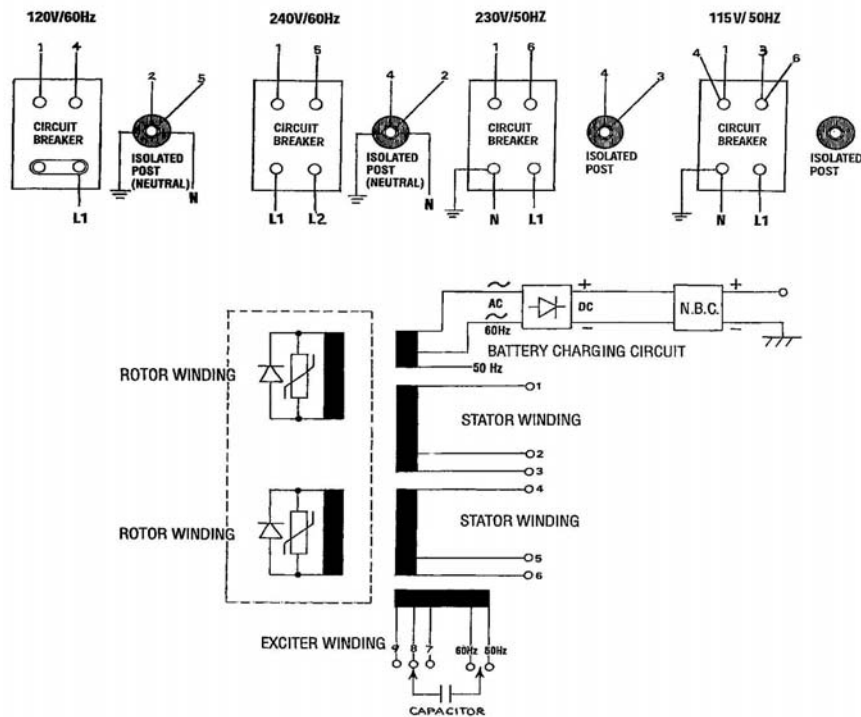

Note: The labor and material costs associated with cycle conversion are the responsibility of the Owner/Operator.

