

SERVICE BULLETIN

DATE: 30 May 1990

BULLETIN NUMBER: 184

MODEL: 38B Four & 42B Four

SUBJECT: Operators Manual Publication # 37435 Edition One March, 1988

An error has been found relating to the cylinder head bolt torque specifications shown on page 85 for the propulsion engine models 38B Four & 42B Four. Remove and discard page 85 and replace it with the attached page, (revised May 1990), containing the correct cylinder head torque specifications.

Torquing Cylinder Head Bolts (W 35B THREE Engine)

Tighten the cylinder head bolts according to the sequence shown in the illustration shown to the right. Make sure the engine is cold when this is done. Before applying the specified torque to the bolt, loosen it 1/4 to 1/2 of a turn and then apply the torque. Follow this procedure according to the numbered sequence shown in the illustration to the right.

Bolts # 4,5,6,7,8,9,10 and 11 are tightened between 79.5 to 86.8 lb-ft (11 to 12 kg-m).

Bolts # 1,2 and 3 are tightened between 50.6 to 57.8 lb-ft (7 to 8 kg-m).

FRONT OF ENGINE

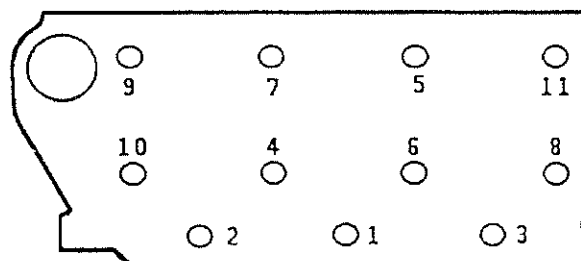

Torquing Cylinder Head Bolts (W 38B FOUR and W 42B FOUR Engine)

Tighten the cylinder head bolts according to the sequence shown in the illustration shown to the right. Make sure the engine is cold when this is done. Before applying the specified torque to the bolt, loosen it 1/4 to 1/2 of a turn and then apply the torque. Follow this procedure according to the numbered sequence shown in the illustration to the right.

Bolts # 1,2,5,6,7,8,11,12,13,14 are tightened between 79.5 to 86.8 lb-ft (11 to 12 kg-m).

Bolts # 10,4,3 and 9 are tightened between 50.6 to 57.8 lb-ft (6.5 to 8.0 kg-m).

FRONT OF ENGINE

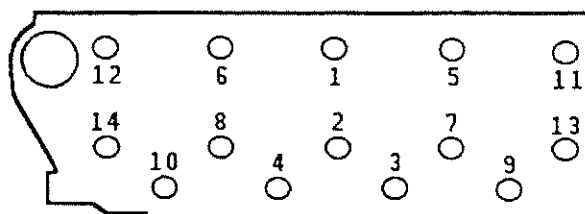

NOTE: Revised May, 1990

Valve Clearance Adjustment (W 35B THREE Engine)

CAUTION

Adjust the valve clearance when the engine is cold. Valves are adjusted by cylinder in the firing order of the engine.

Tighten the cylinder head bolts to the specified torque before adjusting the valves. (See page 85.)

1. Pull off the air breather pipe from the rocker cover, and take off the rocker cover bolts and the rocker cover.
2. Adjust the valve clearances at TDC (Top Dead Center) for each cylinder when they are on their compression stroke (see below). Remember the engine's firing order is 1-3-2. You may find that turning the engine's crankshaft is more easily accomplished when the engine's glow plugs are removed before the crankshaft is rotated.

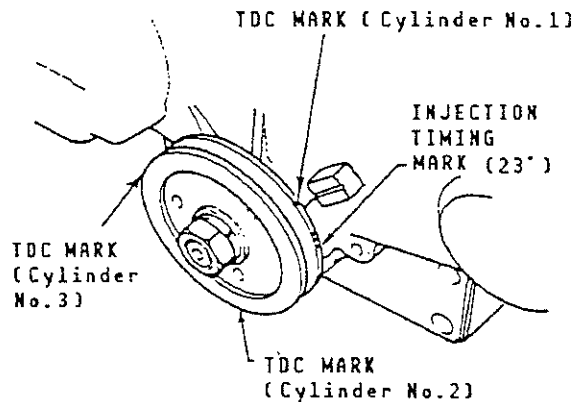

A. Align the timing mark on the gear case with the timing mark on the crankshaft pulley indicated for cylinder No. 1 (the one next to the three injection timing marks). In this position, the No. 1 cylinder is at its top Timing Mark while dead center on its compression stroke. Check both intake and exhaust stroke. If the valves have no specified clearance, adjust by means of the adjusting screws. Remember to align the timing marks properly; if not, the valve may be pushed up by the piston, depending on the position of the cam lobe. Be sure to check the valves for this cylinder - they both should be closed.

B. Next the No. 3 cylinder: Turn the crankshaft clockwise 240° so the TDC mark for the No. 3 cylinder, on the front crankshaft pulley, is approximately at the position shown in the illustration above. Now adjust the intake and exhaust valves for cylinder No. 3. Be sure to check the valves for this cylinder - they both should be closed.

C. Last is the No. 2 cylinder: Turn the crankshaft clockwise another 240° to position the TDC mark on the crankshaft pulley approximately at the position shown in the illustration shown above. Now adjust the intake and exhaust valves for cylinder No. 2. Be sure to check the valves for this cylinder - they both should be closed.

Adjust each valve's clearance by inserting a 0.010 inch (0.25 mm) feeler gauge between the rocker arm and the valve stem.

ADJUST VALVES TO 0.010 INCHES
(0.25 MM)

