

NOTE:
1. REMOVE JUMPER WHEN CONNECTING A SECOND REMOTE PANEL.

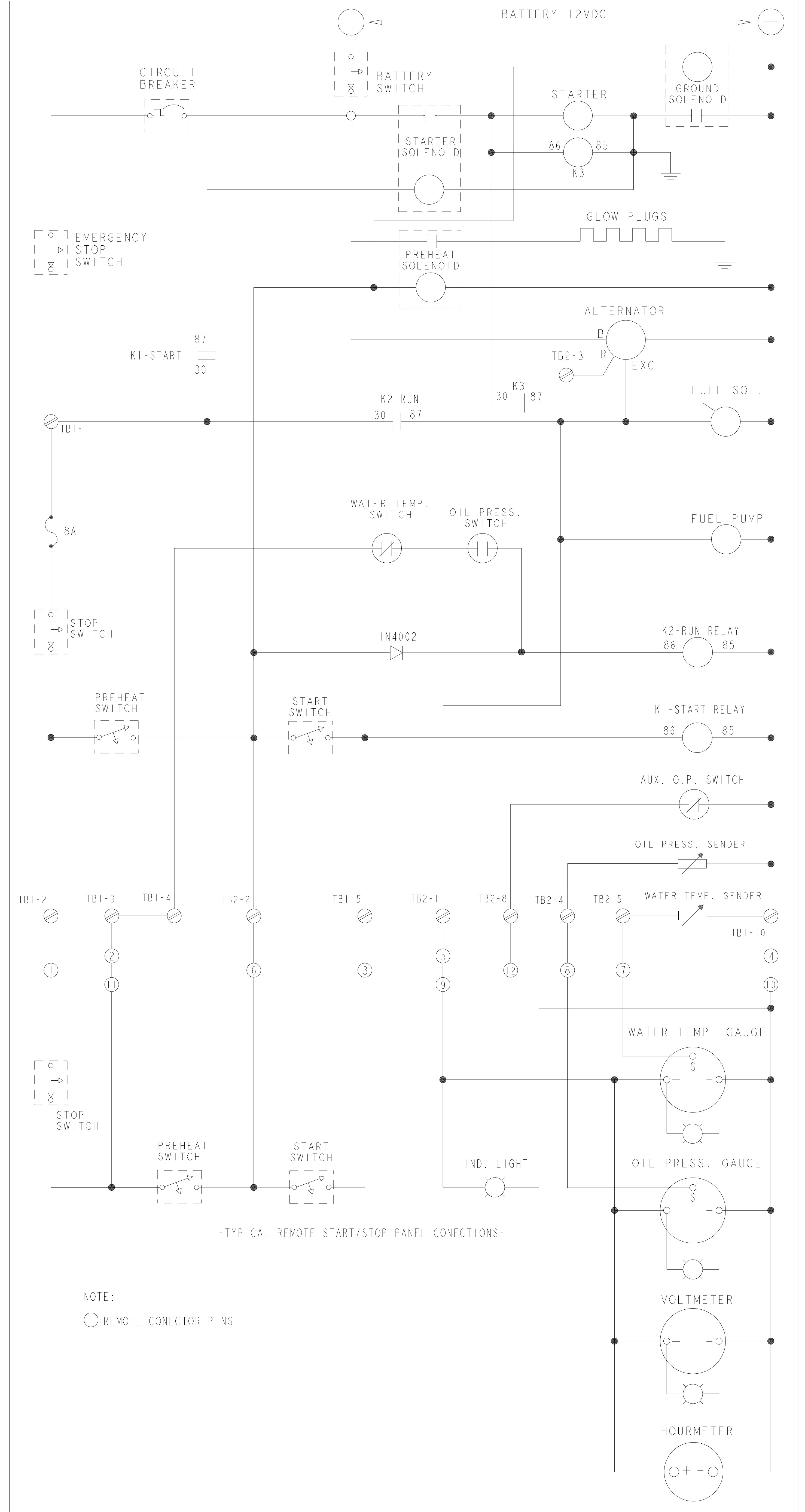
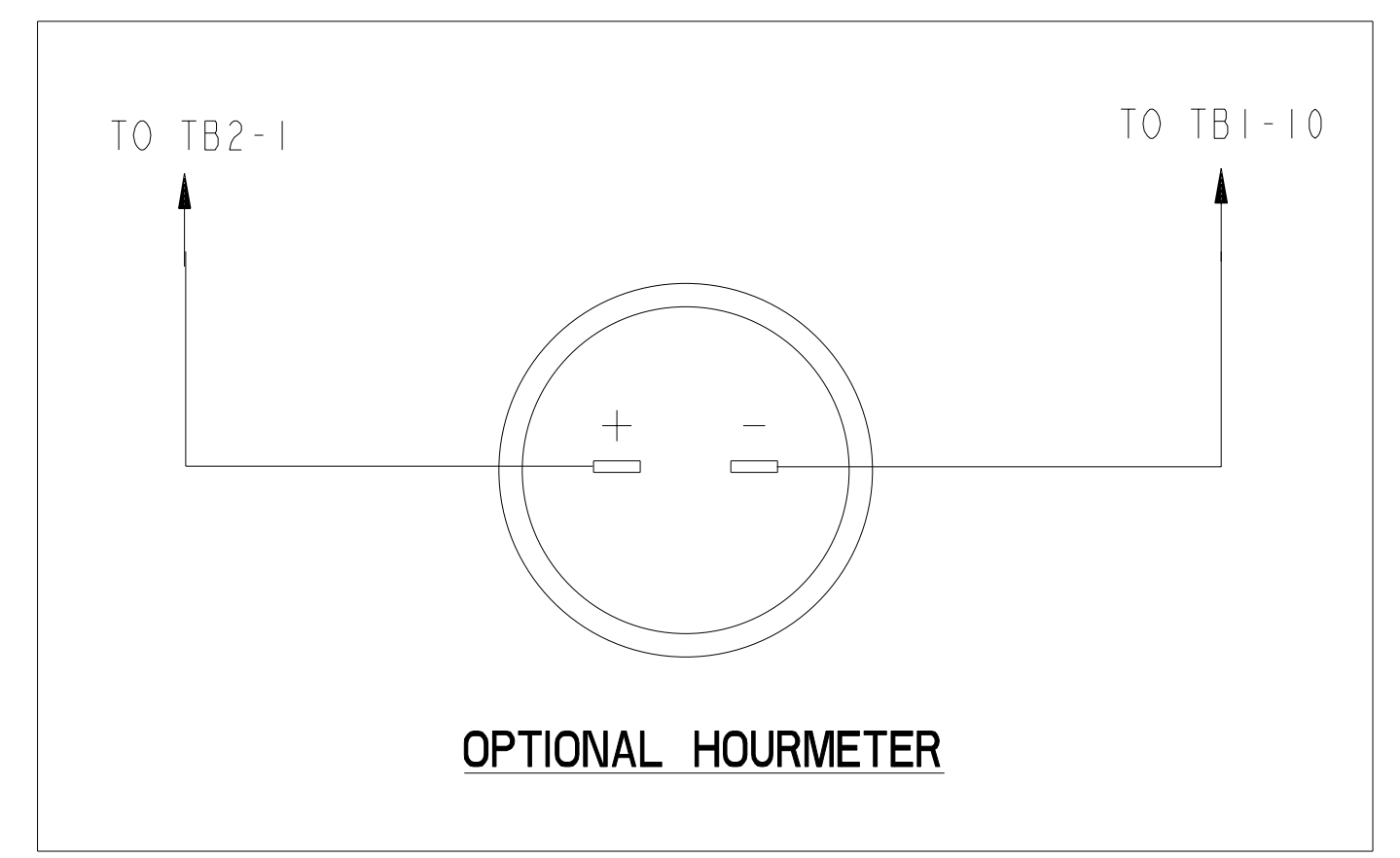
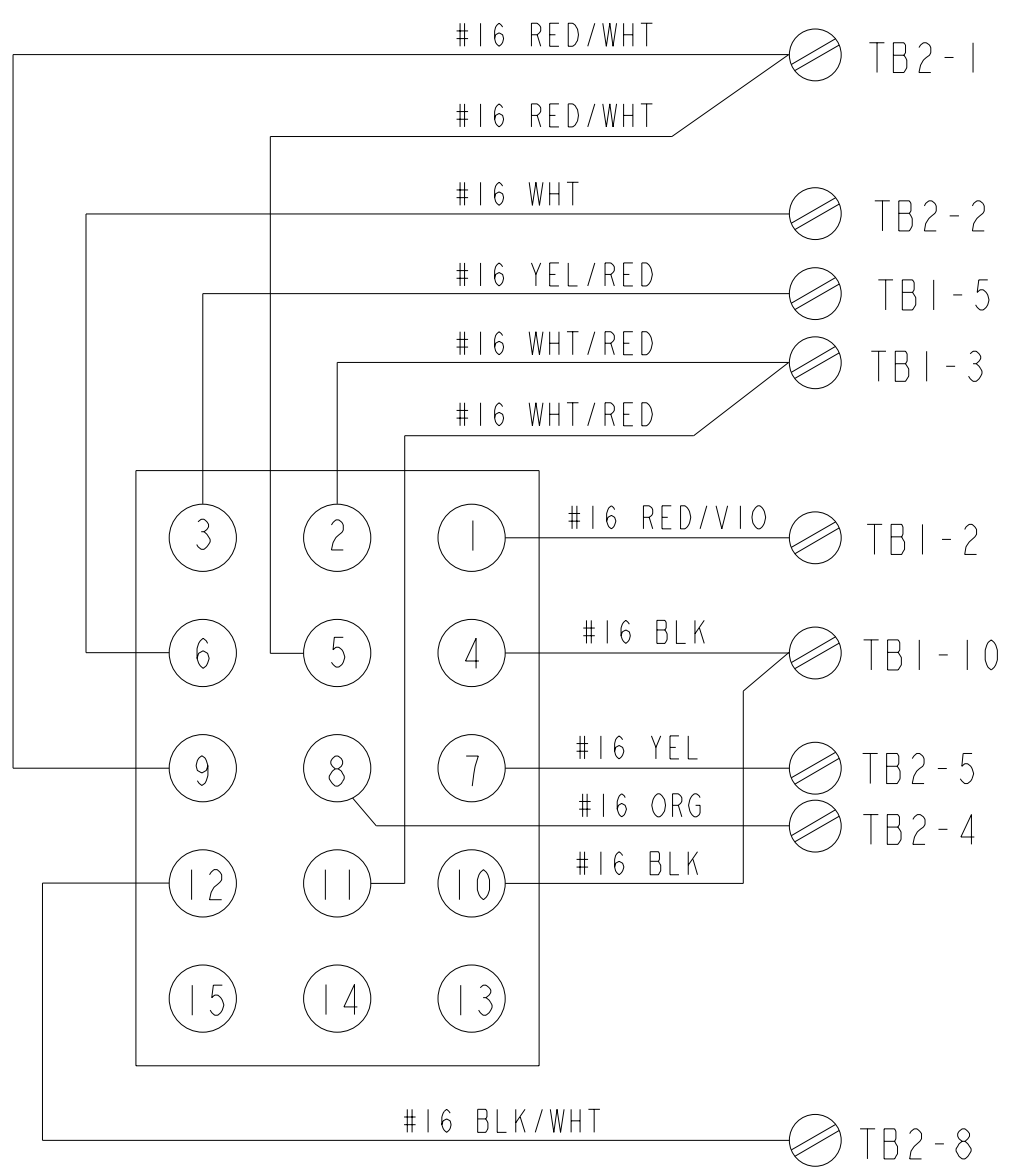

ECO NO.	DATE	REV.	REVISION RECORD	AUTH.	DR. BY	ECO NO.	DATE	REV.	REVISION RECORD	AUTH.	DR. BY

TOLERANCES (UNLESS OTHERWISE NOTED)		WESTERBEKE CORPORATION AVON MA. 02322	
INCHES	MILLIMETERS	TITLE	
XX : .005	X : .005	WIRING DIAGRAM/SCHEMATIC, 7.6 BTD MINI, UNGROUNDED	
CAST : .03	.XX :	DRAWN BY	DATE
FINISH : .2		APPROVED BY	DATE
DIMENSIONS		SCALE	DRAWING NUMBER
INCHES		NONE	46052
MILLIMETERS		SHT. 1 of 1	REV.
(WHEN APPLICABLE)		E	