

WESTERBEKE MARINE DIESEL ENGINE

MODEL FOUR-236

SAFE DEPENDABLE POWER

FOR LARGE AUXILIARIES AND SMALL WORK BOATS where high torque over long periods is more important than a high horsepower rating.

The FOUR-236 is another of the WESTERBEKE family of lightweight, compact marine diesel engines. Good design and fine workmanship make this a truly dependable diesel engine — one that, with proper maintenance, will give smooth, trouble-free service year after year.

Where space in a boat is limited, try the FOUR-236. We have made every effort to reduce overall dimensions and to make the engine accessible for routine maintenance in usual yacht installations. We have a variety of engine mounts which may be required when the engine is installed in the wineglass sections aft in a sailboat.

Owners of our FOUR-236 report unusually good fuel economy. While we all recognize the safety and economy of diesel fuel, the Westerbeke FOUR-236 engine squeezes extra miles out of each tankful.

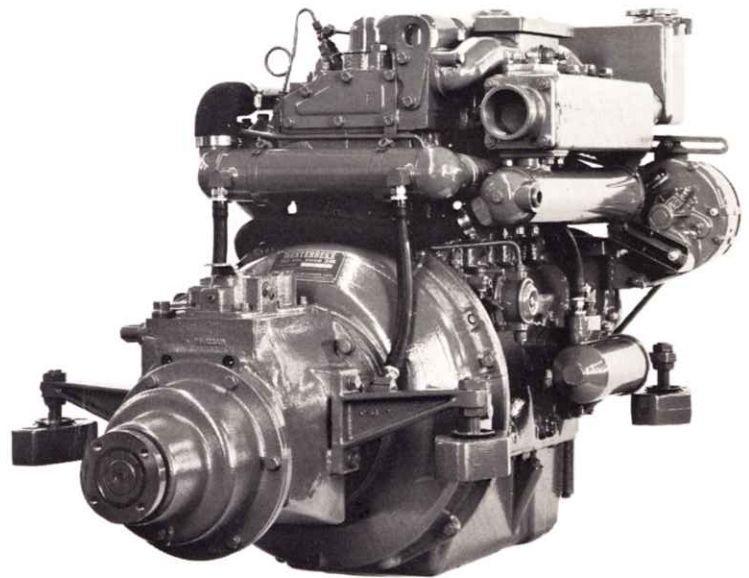

For the finest in lightweight, compact marine diesel engines, see Westerbeke. In the 50 to 70 h.p. range, try the FOUR-236.



J. H. WESTERBEKE CORP.

35 TENEAN STREET, BOSTON, MASSACHUSETTS 02122

MANUFACTURERS & DISTRIBUTORS OF INDUSTRIAL & MARINE ENGINES AND GENERATORS

Reverse and Reduction Gear Dimensions

Ratio	Length A	Offset B	Radius C
Direct Drive	10 3/4"		
1.5:1	16 3/8"	7/8"	4 1/2"
2.0:1	16 3/8"	1 1/8"	4 1/2"
2.5:1	16 3/4"	1 7/8"	5 1/4"

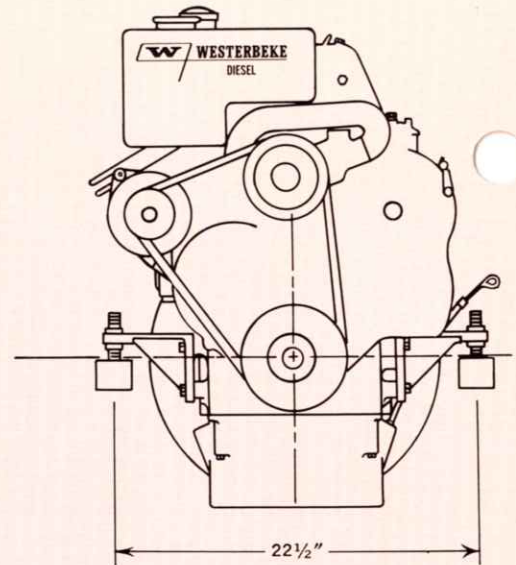
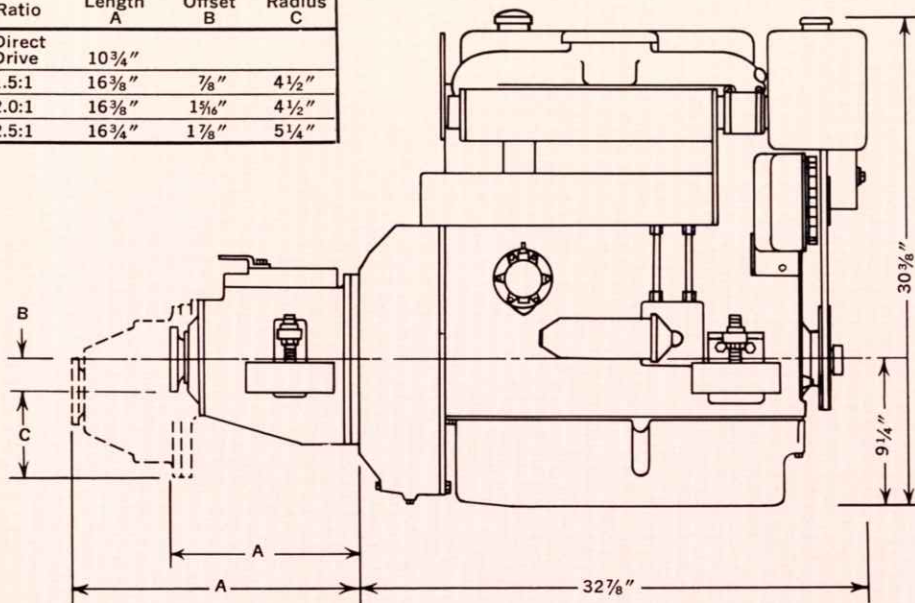

SPECIFICATIONS FOUR-236 FEATURES

- Type:** 4-cylinder, in line, 4 cycle.
- Displacement:** 236 cu. in. — Bore 3.875". Stroke 5".
- Power:** 72 HP at 2500 RPM intermittent. 63 HP at 2250 RPM continuous. (See curve below.)
- Compression Ratio:** 16:1
- Weight:** 980 pounds with hydraulic reverse and reduction gear.
- Dimensions:** See drawing above.
- Cylinder Block:** One piece iron alloy casting with dry cylinder liners. Full length water jackets.
- Cylinder Head:** Iron alloy casting with wire mesh reinforced asbestos gasket. Overhead valves.
- Crank Shaft:** Chrome molybdenum steel forging.
- Main Bearings:** Five replaceable main bearings.
- Cam Shaft:** High duty cast iron with three pressure-lubricated bearings.
- Connecting Rods:** Molybdenum steel forgings, with replaceable bearings.
- Pistons:** High silicon aluminum alloy castings.
- Lubricating System:** Full pressure oil supply delivered by rotary gear-driven pump, with relief valve, full-flow filter, and lube oil cooler.
- Cooling System:** Fresh water, cooled either by on-board heat exchanger and raw water pump or by a keel cooling system, cools engine block, exhaust manifold, engine oil, and hydraulic gear oil.
- Fuel Injection System:** Diaphragm lift pump supplies the rotary distributor injection pump through a paper-element secondary fuel filter. Multi-hole atomizers discharge fuel into combustion chamber formed in piston crown.
- Electrical Equipment:** 12 volts. 40 ampere alternator standard.
- Starting:** 12 volt positive engaging heavy duty starting motor. A Thermostart heater fitted in intake manifold aids cold starting.
- Reverse Gear:** Manual and hydraulic gears in the following ratios: direct drive, 1.5:1, 2:1, 2.5:1, 3:1 for left hand rotation. 1.9:1 and 2.2:1 hydraulic for right hand rotation.

Angle of Installation: 17° maximum.

Standard Equipment: Fresh water cooling system, including raw and fresh water pumps, heat exchanger and exhaust manifold; fuel oil lift pump, injection pump, and primary and secondary filters; lube oil filter, cooler, sump pump and hose; reverse gear oil cooler; 12 volt starter, with switch and keys; 40 amp alternator with oil pressure switch and regulator; and illustrated instruction manual.

Optional Extras: Various instrument panels, adjustable flexible mounts, 60 amp alternator, hi-capacity fuel filter and water trap, "Aqualarm" audible alarm system, and various engine mounting systems.

Service & Parts: Westerbeke marine diesel engines and generator sets are sold by distributors in all major port cities in the United States. For more remote areas, air freight requires only a few days.

The light weight and compact dimensions of the FOUR-236 make it well suited for auxiliary power in large sailing yachts, while its high standards of construction and dependability and excellent fuel economy appeal to operators of small commercial craft.

