

Six cylinder, four cycle smoothness in a lightweight, compact engine

A new generation of marine diesel engines

The new Model 108C Six represents the latest engine design from Westerbeke. With a low and narrow profile it is lightweight and easily installed. The naturally aspirated design provides extra low-end power as well as simplicity and reliability. The standard transmission, fresh water cooling system and captive fail-safe mounts are all oversized for added dependability.

Engineered with a self-bleeding fuel system, front mounted sea water pump, oil drain hose and true one-side servicing, the engine is easily maintained. A comprehensive list of factory designed and installed options allows you to custom tailor your engine to fit your individual requirements.

The presence of Westerbeke in over 65 countries around the world provides customers with easy access to parts, service and technical support world-wide. Established in 1937, Westerbeke is committed to providing its customers with quality products and unequalled sales support.

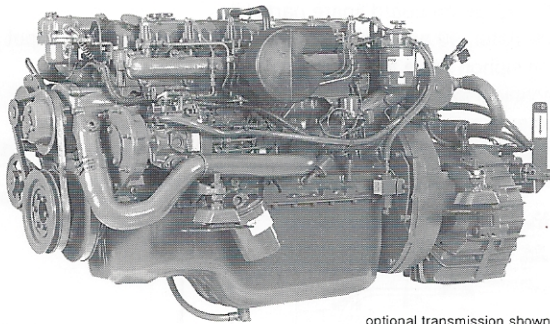

108C Six
Diesel Engine

optional transmission shown

Dimensions

Length	54.4" (1381.8 mm)
Width	26.9" (683.7 mm)
Height	29.3" (744.2 mm)
Weight	932 lbs. (422.8 kilos)

See other side for more dimensional information

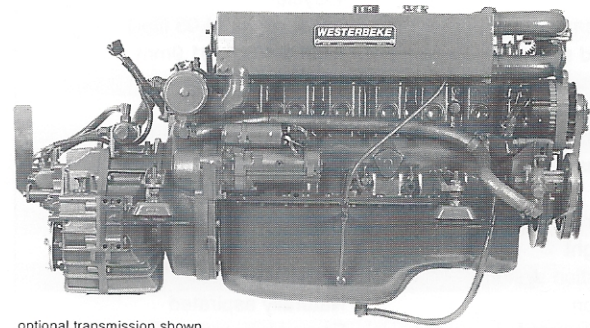

optional transmission shown

108C Six
Diesel Engine

Standard Features

- Fresh water cooling
- Engine prewired to plug-in connector
- Self-bleeding fuel system
- 12 volt, 51 ampere alternator
- Domestic hot water connection
- Coolant recovery tank
- Throttle and shift control brackets
- Low oil pressure and high water temperature alarms
- Belt-driven sea water pump
- Marine transmission, 8 degree down angle with 2.5:1 reduction
- Transmission oil cooler
- Glow plug cold starting aid
- Oversized four point adjustable mounts
- Lube oil drain hose
- Fresh water lube oil cooler
- Flexible fuel supply and return connector
- Operator's Manual and Parts List
- Large list of factory engineered options
- "CE" Mark

Performance Data

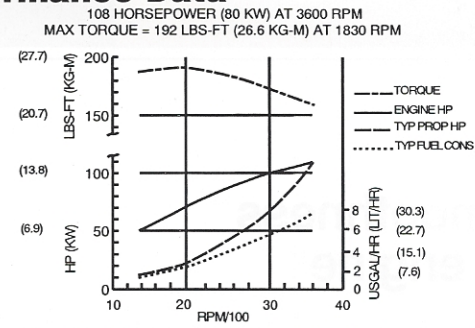

WESTERBEKE RECOMMENDS A PROPELLER THAT WILL ALLOW THE ENGINE TO TURN 3500-3600 RPM UNDERWAY AT FULL THROTTLE

Specification

Number of cylinders	6 Cylinder vertical in-line
Cycles	4 Cycle
Displacement	247.2 cu. in. (4.05 liter)
Bore and stroke	3.62" x 4.00" (91.9mm x 101.6mm)
Compression ratio	21:1
Maximum angle of installation	Not to exceed 14°
Maximum angle of rotation	Not to exceed 25°
Crankshaft, direction of rotation	Counterclockwise as viewed from flywheel end
Propeller shaft, direction of rotation	Right hand – std. trans.
Dry weight	932 (422.8 kilos)
Combustion system	Swirl type
Aspiration	Naturally aspirated
Lubrication system	Forced lubrication by gear pump
Cooling system	16 quarts (15.1 liters)
Starting aid	12 volt sheathed type glow plug
Engine stop	Electric
Fuel injection pump	Bosch type
Governor	Centrifugal type
Injectors	Throttle type
Fuel filter	Full flow, spin-on element
Lube oil filter	Full flow, spin-on element
Lubricant capacity	12 quarts (11.3 liters)
Lube oil cooler	Fresh water cooled
Fuel transfer pump	Electrical
Fuel supply and return piping	1/4" ID (6.35 mm) minimum 3/8" ID (9.65 mm) maximum
Starting motor	12 volt, solenoid, actuated shift
Battery charging alternator	50 ampere (12 volts)
Cold cranking amps	250-300 amps
Electrical system	12 volts DC, negative ground

Construction – Engine Components

Cylinder head	Cast Iron
Cylinder block	Cast Iron
Crankshaft	Forged crankshaft, five main bearings
Valves	Overhead valves – rotating type
Fuel System	Self bleeding
Intake system	Intake silencer with air filters for maximum noise reduction
Cooling system	Fresh water-cooled with oversized tube and shell type heat exchanger
Exhaust manifold	Cast aluminum, fresh water-cooled with built-in expansion tank

Standard Equipment

Standard gear ratio	2.5:1
Mounting centers	18.5" and 22.5"
Flexible mounts	Oversized adjustable fail-safe rubber type
Domestic hot water connection	
Coolant recovery tank	
Battery charging alternator	51 amp, 12 volt
Starting aid	
Control brackets	Throttle and shift
Prewired Engine	
Belt-driven sea water pump	
Lube oil cooler in fresh water system	
Lube oil drain hose	
Transmission oil cooler	
Oil fill	Top
Flexible fuel supply and return connection	
Operator's Manual and Parts List	

Optional Equipment

Captain panel with alarm (tachometer with lights)	
Admiral panel with alarms (tachometer with gauges)	
Dual station senders	
Other gear ratios	Consult local Distributor
Remote expansion tank	
Provision for refrigeration compressor	
Muffler and fittings	
"A" and "B" on board spare parts kits	
Alternator, 90 amp single output; 135, 165, 190 dual output	
Anti-siphon valve for overboard cooling discharge water	
Technical Manual	
Exhaust connection (water injected 70° elbow)	
Propeller shaft couplings (rigid/flexible) – available standard sizes	

Dimensions

WEIGHT: 932.0 LBS./423.6 KGS.

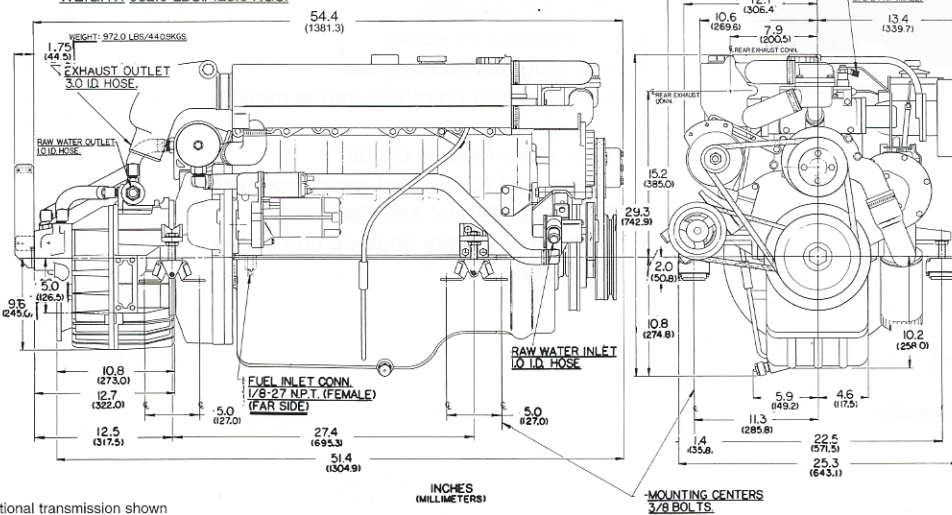

Authorized Dealer