



NEW 1800 RPM 4 kW!



4BCD Diesel Generator



4BCD Diesel Generator

Quiet and Compact

Operating at 1800-rpm with a tuned air intake silencer and four point vibration mounts, the 4BCD runs smooth and quiet. Designed specifically for the tightest installations, this generator has one of the smallest envelopes available in its class. The 4BCD occupies only 5.4 cubic feet of space!

Powerful, Lightweight and Reliable

The 4BCD is powered by an industrial .8 liter engine supplying a full 4 kilowatts while weighing only 358 pounds. A very popular generator, the 4BCD continues to support the strong record of reliability Westerbeke has built supplying generators to the United States Navy and Coast Guard as well as commercial vessels and pleasure craft.

Easy Operation and Maintenance

To minimize engine maintenance, the 4BCD operates at a slow 1800-rpm and is fresh water cooled for longer life. Easy access to all servicing points and individually removable top and side panels of the optional sound enclosure allow easy installation and maintenance.

Full Torque, Power Take-Off Interface

A customer sourced, electric clutch and hydraulic pump can be mounted to the full torque, power take-off interface for use with such items as bow thrusters, compressors, winches and "take-home" systems.

Five Year Limited Warranty

The 4BCD is backed by Westerbeke's 5-year limited warranty. The presence of Westerbeke in over 65 countries around the world provides customers with easy access to parts, service and technical support worldwide. Established in 1937, Westerbeke is committed to providing its customers with quality products and unequaled after sales support.

Standard Features

- Instrument panel and safety stop switch
- Remote start-stop plug-in connection
- Extra oil pressure switch for remote signal or control functions
- Safety shut-downs - high coolant temperature, low oil pressure, high exhaust temperature
- A.C. circuit breaker (single phase)
- 17 amp battery charger
- Power take-off interface
- Self-bleeding fuel system
- Fresh water cooling and coolant recovery tank
- 45 degree water injected exhaust elbow
- Gear driven raw water pump
- Tuned air intake silencer
- Vibration mounts - fail safe rubber type
- Lube oil drain hose and drip tray
- Oil fill - top and side
- Belt guard
- Operators' manual and parts list
- EPA certified
- "CE" mark

Optional 4BCD Sound Guard



Sound Guard Dimensions

Length	32.8" (833.1 mm)
Width	20.6" (523.2 mm)
Height	22.3" (566.4 mm)
Weight	51.3 lbs. (23.27 kilos)

Generator Design

DESIGN: Brushless, four pole, revolving, power takeoff.
VOLTAGE REGULATION: Standard +/- 5% no load to full load.
FREQUENCY REGULATION: 3 Hz (5%) no load to full load.
INSULATION: Class "H", as defined by NEMA MG1-1.65.

TEMPERATURE RISE: Within NEMA MG1-22.40 definition when operating at full load.

COOLING: Cast centrifugal blower, direct connected.

ELECTROMAGNETIC INTERFERENCE LEVEL: Exceeds requirements for most marine radio-telephones and standard TVs.

Model	Electrical Characteristics					Rating		Engine	
	Volts	Amps	Hertz	Phase	Wire	Power Factor	KW	RPM	Start
4.0 BCD-614	120	33.3	60	1	4	1.0	4	1800	Remote

* 60 hertz only.

Specifications

Number of cylinders	3 Cylinder vertical in-line
Type	4 cycle
Displacement	49.31 cu. in. (.808 liter)
Bore and stroke	2.76" x 2.76" (70.0 mm x 70.0 mm)
Compression ratio	23:1
Rated rpm	60 Hz - 1800 rpm
HP @ 1800 rpm	9 hp
Maximum angle of operation	Not to exceed 25° in all directions
Exhaust elbow connection	2" OD (50.8mm)
Sea water connection	1" OD (25.4mm)
Dry weight	358 lbs. (152.4 kilos)
Combustion system	Swirl type
Aspiration	Naturally aspirated
Lubrication system	Forced lubrication by gear pump
Cooling system	4 quarts (3.78 liters)
Starting aid	12 volt sheathed type glow plug
Full load fuel consumption	0.54 GPH (2 LPH) (approx.)
Fuel injection pump	Bosch type, with solenoid shutoff
Governor	Centrifugal type
Injectors	Throttle type
Fuel Filter	Secondary, replaceable type
Fuel transfer pump	12 volt electric type
Fuel supply and return piping	1/4" ID (6.35 mm) minimum 3/8" ID (9.53 mm) maximum
Lube oil filter	Full flow, spin-on element

Lubricant capacity	3.2 quarts (3.05 liters)
Starting motor	12 volt, solenoid, actuated shift
Battery charging	17 amps, regulator type
Cold cranking amps	190 amps
Electrical system	12 volts DC, negative ground

Construction - Engine Components

Cylinder head	Cast Iron
Cylinder block	Cast Iron
Crankshaft	Forged crankshaft, four main bearings
Valves	Overhead valves, rotating type
Fuel System	Self bleeding
Intake system	Tuned intake silencer for maximum noise reduction
Cooling system	Fresh water-cooled with heat exchanger
Exhaust manifold	Cast aluminum, fresh water-cooled

Optional Equipment

Remote start-stop panel
15' & 30' connectable panel ext. harness (up to 60'/18.3m)
Dual station engine instrument panel with senders
Ship-shore switch
Power takeoff adapter
Fuel/water Separator
Hydro-hush muffler and fittings
"A" on board spare parts kits; "B" extended cruising spare parts kit
Anti-siphon valve for overboard cooling discharge water
Sound Guard sound enclosure

Dimensions

Inches
(millimeters)

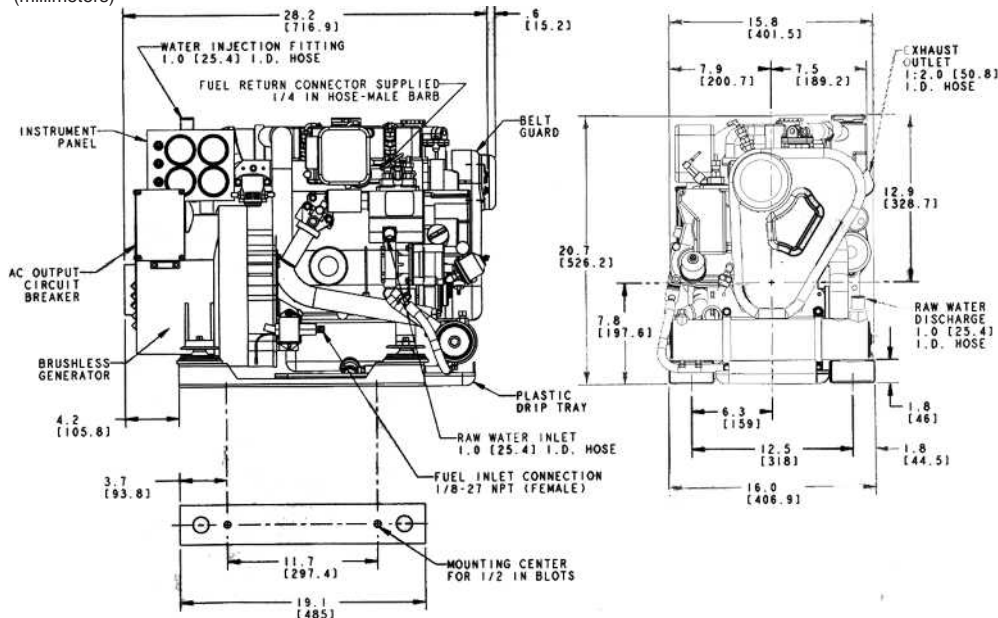

Distributor/Dealer