

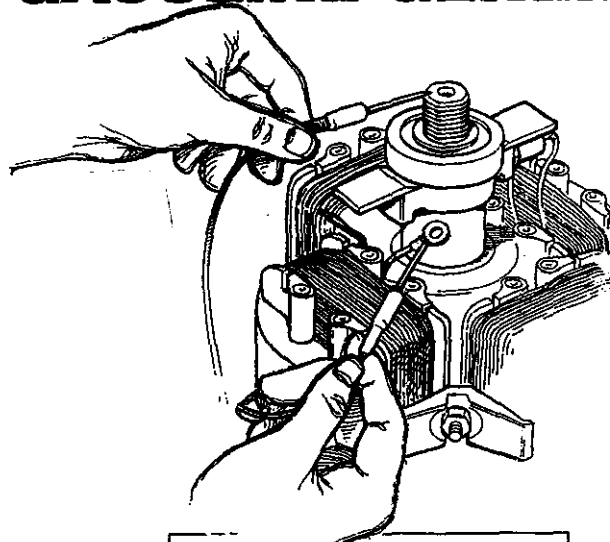

# **ELECTRICAL TESTING AND TROUBLESHOOTING GUIDE**

## **LOW PROFILE CAPACITOR EXCITED AC GASOLINE GENERATORS**



FIRST EDITION  
SEPTEMBER 2007

**WESTERBEKE**

WESTERBEKE CORPORATION • 150 JOHN HANCOCK ROAD  
MYLES STANDISH INDUSTRIAL PARK • TAUNTON MA 02780  
WEBSITE: [WWW.WESTERBEKE.COM](http://WWW.WESTERBEKE.COM)



Member National Marine Manufacturers Association

# TABLE OF CONTENTS

<b>BC Generator (5.0/7.0 Kw)</b> .....	2
Description.....	2
<b>BC Troubleshooting (Chart) Mecc Alte</b> .....	3
Internal Wiring Schematic.....	3
<b>Testing the BC Rotor - Mecc Alte</b> .....	4
<b>BC Troubleshooting (Chart) Coliseum</b> .....	5
Internal Wiring Schematic.....	5
<b>Testing the BC Rotor - Coliseum</b> .....	6
<b>Testing the Diodes</b> .....	7
<b>Control Panel Components</b> .....	7
<b>BC Generators Troubleshooting</b> .....	8
No AC Voltage.....	8
Exciting the Generator.....	8
Reaction during Excitation.....	9
Testing the Exciter Windings .....	10
Exciter Winding Integrity .....	10
Testing Continuity .....	11
Testing Capacitors .....	11
<b>BC Generator (Exploded View)</b> .....	12
<b>Wiring Diagram #46876</b> .....	13

# **BC GENERATOR ELECTRICAL TESTING**

The following field tests should be performed by a qualified technician. Proper safety precautions must be followed as most of these tests are executed with the generator operating or connected to ships power. **AC voltage is lethal.**

If generator problems persist, contact your Westerbeke dealer.

# BC GENERATORS 5.0/7.0 KW

## DESCRIPTION

The BC generator is a brushless, self-excited generator which requires only the driving force of the engine to produce an AC output. The stator houses two sets of windings; the main stator windings and the exciter windings. When the generator is started, residual magnetism in the four rotating poles induces a voltage in the stator which then generates an even larger voltage in the exciter windings. This mutual build up of voltage in the four rotating poles and in the exciter windings quickly reaches the saturation point of the capacitor(s) and a regulated energy field is then maintained in the stator. At the same time, this regulated field produces a steady voltage in the stator windings which can then be drawn off the generator's AC terminals to operate AC equipment. The generator is a single-phase, reconnectable 120 volt AC two-wire or 115 volt AC two-wire or 230 volt AC two-wire, at 50 hertz.

**Winding Connections:** The single-phase synchronous generator has 4 stator leads and can be configured to 120 volt output.

**Bearings:** The bearings are sealed type and permanently greased requiring no maintenance during their working life (approx. 30,000 hours).

## PRELIMINARY CHECKING

Before electrical testing, check for proper engine speed/hertz adjustment. Low engine speed will cause low AC voltage output, high engine speed-high AC output.

Refer to *WESTERBEKE'S* operators manual or service manual for engine speed/hertz adjustment or for other possible engine related problems.

Before testing, get a clear explanation of the problem that exists, be certain it relates to generator components.

**⚠ WARNING:** AC and DC circuits often share the same distributor panel. Be certain to unplug AC power cords and shut down DC/AC Inverters. Simply switching off circuit breakers will not do the job since it will still leave hot wires on the supply side of the panel.

## INTRODUCTION TO TROUBLESHOOTING

The following test procedures can be used to troubleshoot *WESTERBEKE'S 4 POLE DUAL EXCITER CIRCUIT BRUSHLESS GENERATORS*. Due to the simplicity of the generator, troubleshooting is relatively easy.

Field testing and repairing can be accomplished with basic tools and repair parts which should include the following:

A quality multimeter (multitester) capable of reading less than one ohm and with a specific diode testing function.

Basic electrical tools including cutters, soldering iron, wire strapper/crimper, terminal connectors, etc.

Repair parts such as diodes, fuses, bridge rectifier, etc.

**⚠ CAUTION: (ON SOLDERING)** When soldering, use a large enough soldering iron to get the job done quickly. Excessive heat will damage the diodes. Also make certain no soldering splashes onto the windings as it will melt the insulation.

## ROTATING FIELD/AUXILIARY WINDINGS

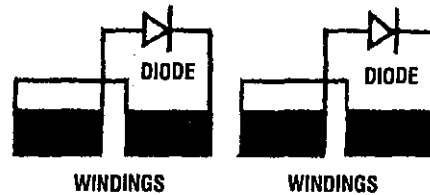

Two sets of windings are found in the rotor assembly. An AC voltage is produced in two groups of windings as the rotor turns at its rated rpm. This AC voltage passes through each of the two diodes mounted on the isolated fixture just before the rotor carrier bearing. The AC sine wave is changed to DC and this DC voltage is passed through the two groups of rotating field windings producing a DC field around these windings. This field affects the AC winding of the two main stator groups inducing an AC voltage in these windings that is available at the AC terminal block connections.

# BC GENERATORS TROUBLESHOOTING CHART MECC ALTE

(REFER TO THE WIRING SCHEMATIC BELOW)

A,B,C,&D refer to the components of the *INTERNAL WIRING DIAGRAM* and their test procedures in the following pages.

**NOTE:** This fault finding chart is compiled assuming the engine is operating at the correct speed/hertz.

FAULT	CAUSE	TEST/CORRECTION
<b>No AC Output</b>	Shorted stator	<b>B</b>
	Open stator	<b>B</b>
	Shorted diode (two)	<b>A</b>
<b>Residual Voltage 4-6 VAC (Hot N) at No-Load</b>	Faulty capacitor (two)	<b>C</b>
	Open exciter	<b>B</b>
	Shorted exciter	<b>B</b>
	Engine speed (hertz) is too low	Adjust*
	Electrical connections are faulty	Inspect wiring connections
<b>High AC Output at No-Load</b>	Incorrect voltage tap on capacitor	<b>C</b>
	Incorrect capacitor	<b>C</b>
	Incorrect hertz tap on capacitor	<b>C</b>
	Engine speed (hertz) too high.	Adjust*
	Faulty rotor winding	<b>A</b>
<b>Low AC Output 60-160V</b>	Faulty diode	<b>A</b>
	Faulty capacitor	<b>B</b>
	Faulty capacitor	<b>B</b>
<b>Voltage Drop Under Load (or at No-Load)</b>	Faulty diode	<b>A</b>
	Faulty capacitor	<b>C</b>
	Engine speed (hertz) is too low	Adjust*
<b>No Battery Charge Low Battery Charge</b>	Faulty Bridge rectifier	<b>D</b>
	Faulty integral controller	<b>D</b>
	Blown fuse	<b>B</b>
	Faulty wiring	<b>B</b>
<b>High Voltage Output when Load is applied</b>	Engine speed (hertz) is too high	Adjust*
<b>Unstable Voltage</b>	Electrical connections are faulty, loose	Inspect wiring connections
<b>Noisy Operation</b>	Faulty support bearing	Inspect rear bearing**
	Generator rotor connection to engine is loose	Check rotor security**

## WINDING RESISTANCE VALUES (OHMS)

	5.0KW	7.0KW
<b>MAIN STATOR:</b>		
#1 TO #3	0.4	0.2
#4 TO #6	0.4	0.2
<b>ROTOR:</b>		
(Each pair)	4.0	2.0
<b>EXCITER:</b>		
(Each winding)	3.9	2.5
<b>CHARGE WINDING:</b>	0.08	0.08

## INTERNAL WIRING SCHEMATIC

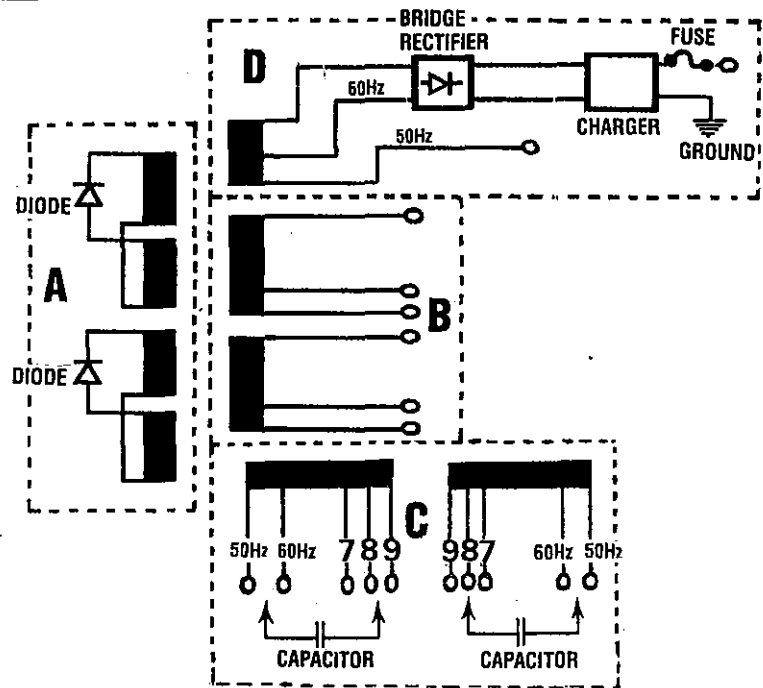

- A** - ROTOR WINDINGS
- B** - STATOR WINDINGS
- C** - CAPACITOR WINDING
- D** - BATTERY CHARGE WINDING

\* Refer to the *GENERATORS OPERATOR MANUAL*

\*\* Refer to the *GENERATORS SERVICE MANUAL*

# TESTING THE BC ROTOR (MECC ALTE MODEL)

## MECC ALTE MODEL

THE MECC ALTE MODEL GENERATOR IS IDENTIFIED BY ITS LOUVERED BACK COVER THAT IS FASTENED BY FOUR HEX SCREWS

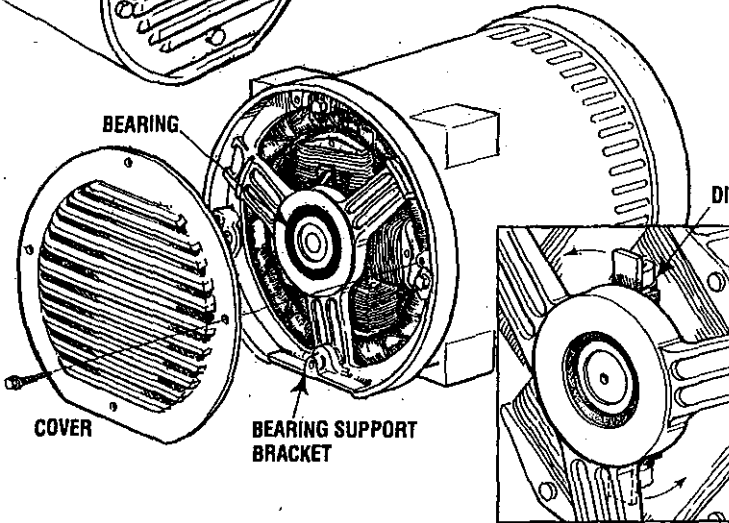

Testing the Mecc Alte generator can be accomplished without removing the bearing support bracket. Simply turn the armature to allow access for the testing as shown.

## TESTING THE WINDINGS THROUGH THE DIODES

Rotate the armature into position to access a diode. To make a quick test of the windings, assume the diode to be OK and test the connection at each end of the diode. Turn the armature and test the other side.

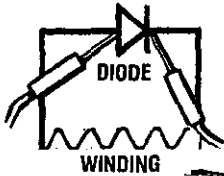

ROTATING FIELD/AUXILIARY WINDING RESISTANCE VALUE  
**4.0 OHM**

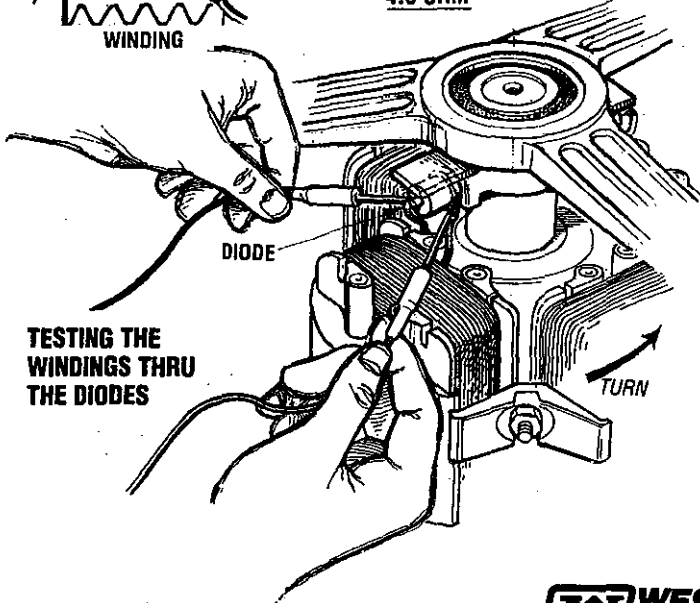

TESTING THE WINDINGS THRU THE DIODES

## TESTING THE ROTOR FIELD WINDINGS

Unsolder the winding connection from the diode and carefully remove the diode from its isolated heat sink using a thin walled, deep well 7/16" (11mm) socket.

With the diode removed, both leads for the first group of rotating field/auxiliary windings will be isolated with no interference from a possibly faulty diode.

Check the resistance value of the rotating windings by placing an ohmmeter's probes across the two exposed leads.

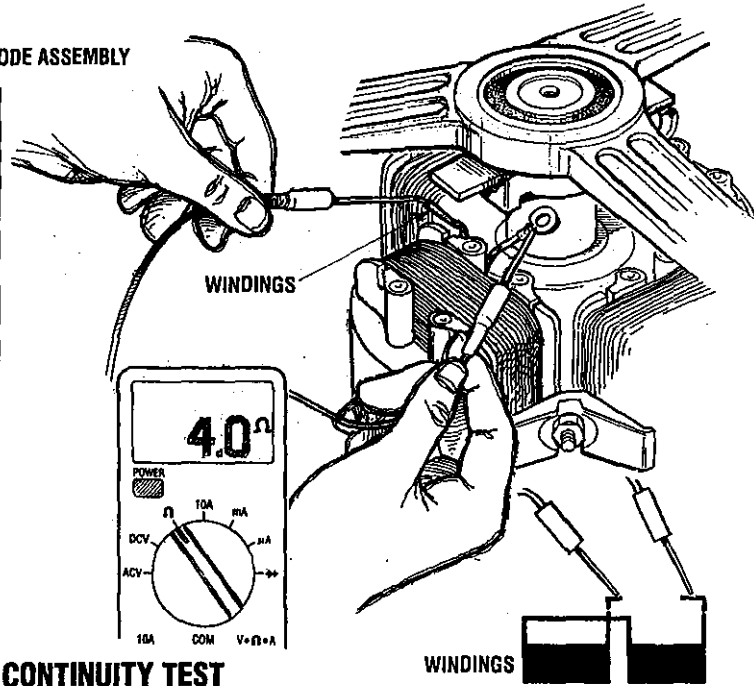

## CONTINUITY TEST

Check that no continuity exists between either of the winding leads and the generator shaft. If continuity is found, there is a short in the windings.

Repeat these tests on the second set of windings on the opposite side.

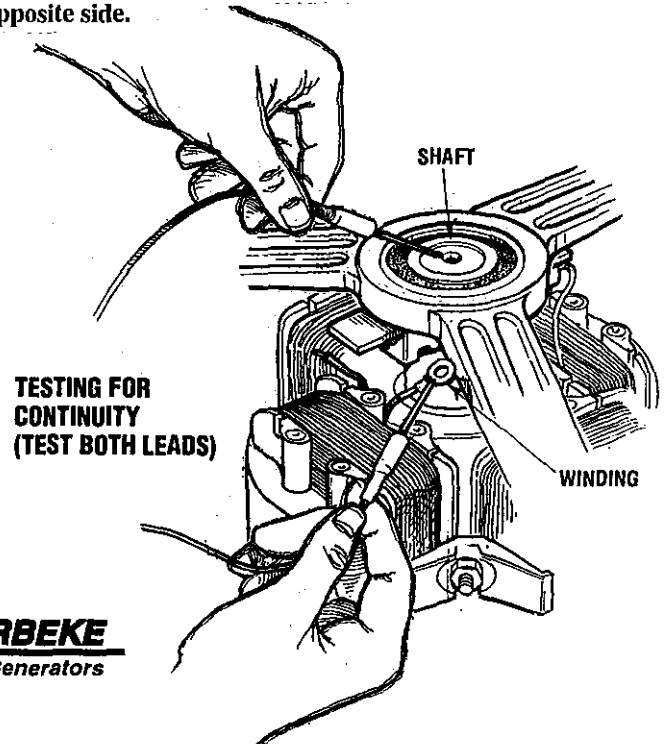

TESTING FOR CONTINUITY (TEST BOTH LEADS)

# BC GENERATORS TROUBLESHOOTING CHART COLISEUM MODEL

(REFER TO THE WIRING SCHEMATIC)

FAULT	CAUSE	TEST
NO AC VOLTAGE OUTPUT	1. Shorted stator 2. Open stator 3. Rotor diode open/shorted	1. W1 & W2 2. W1 & W2 3. D1 & D2
RESIDUAL VOLTAGE 3-4 VAC LINE TO N AT NO LOAD	1. Faulty capacitor 2. Open exciter winding 3. Shorted exciter 4. Engine speed low 5. Electrical connection	1. C1 2. EW1 - EW2 3. EW1 - EW2 4. Adjust 5. Inspect
HIGH AC OUTPUT AT NO LOAD	1. Engine speed too high 2. Capacitor connection	1. Adjust 2. Correct
LOW AC OUTPUT 60-100 VAC	1. Faulty rotor winding 2. Faulty diode (shorted) 3. Faulty capacitor 4. Faulty exciter windings	1. RW 2. D1 or D2 3. Check rating 4. Check windings
VOLTAGE DROP UNDER LOAD	1. Faulty diode 2. Engine speed low 3. Faulty capacitor	1. D1 or D2 2. Check/adjust 3 Check rating
HIGH VOLTAGE OUTPUT (NO LOAD/LOADED)	1. Engine speed	1. Check/adjust
UNSTABLE OUTPUT	1. Electrical connection 2. Engine speed	1. Check 2. Check/adjust

## POTENTIAL BC PROBLEMS

### Diodes

1. An open diode will cause the loss of any rotating field.
2. A shorted diode will weaken the rotating field.

### Field Windings

1. An open field winding will cause the loss of the rotating field.
2. A shorted field winding will cause a weak rotating field.
3. Test each diode individually. A resistance value should be found through the diode in one direction and, with the meter probes reversed, show no ohm value.

## GENERATOR WINDING SCHEMATIC

**NOTES:** For 60Hz operation: Connect capacitors to E31-E41 and to E11-E21.

For 50Hz operation: Connect capacitors to E31-E42 and E11-E22.

EW1-Exciter Windings 1  
EW2-Exciter Windings 2  
BCW-Battery charging windings  
RW-Rotor Winding

W1-Stator Winding 1  
W2-Stator Winding 2  
C-Capacitor  
D1/D2-Diodes

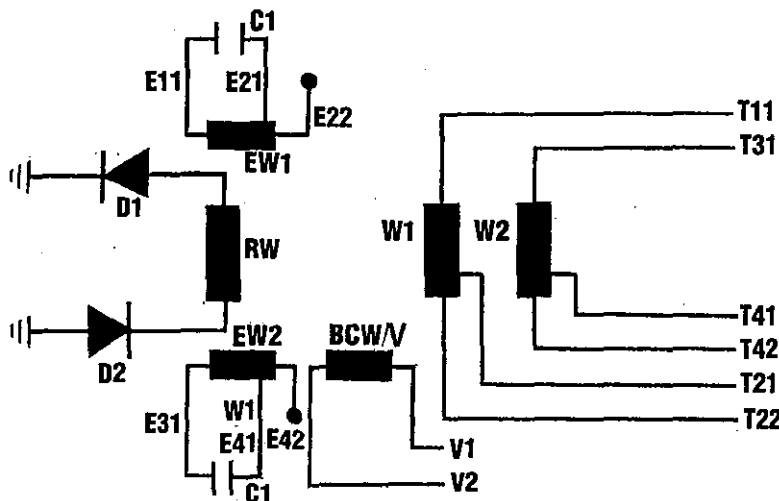

**RESIDUAL VOLTAGE TEST** (unit operating at rated hertz)  
Exciter circuit capacitor disconnected from exciter windings  
**MAIN STATOR RESIDUAL VOLTAGE** (Live to neutral)  
3-4 VAC

### EXCITER WINDING GROUP

EW1	E31-E42	5-6 VAC
EW2	E11 to E22	5-6 VAC

**NOTE:** The presence of correct residual voltage is an indication the winding is O.K. (main stator or exciter windings).

### WINDING RESISTANCE VALUES (OHMS)

	5.0KW	7.0KW
<b>EXCITER WINDINGS:</b>		
EW1 (E11 & E22)	3.4	2.2
EW2 (E31 & E42)	3.4	2.2
<b>BATTERY CHARGING:</b>		
BCW	0.5	0.5
<b>STATOR WINDINGS:</b>		
W1 (T11 & T22)	0.6	0.9
W2 (T31 & T42)	0.6	0.9
<b>ROTOR WINDINGS:</b>		
RW	1.7	2.2

# TESTING THE BC ROTOR COLISEUM MODEL

COLISEUM MODEL

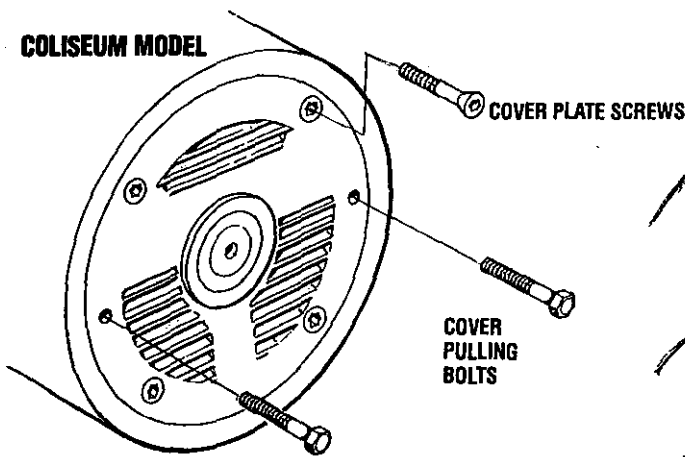

## REMOVE THE COVER PLATE

1. Remove the four cover plate screws.
2. Insert two 8mm x 35mm-1.25 pitch bolts into the two left and right vacant holes as shown.
3. Tighten these two bolts in sequence. This will pull the cover plate off the generator, exposing the rotor assembly with the bearing in place.
4. When re-installing, place a small amount of petroleum jelly on the rotor bearing "O" ring located in the cover boss.

Position the cover onto the bearing and thread the allen head screws back into place (finger tight).

Tighten the screws in a criss-cross manner drawing the end cover onto the bearing. When fully on, tighten the screws securely.

## TESTING THE ROTOR FIELD WINDINGS

Use a thin walled, deep well 7/16" (11mm) socket and remove the diodes from the isolated plate. With the winding connection still attached to the diode test between the connection and the metal of the rotor shaft as shown above, check both sides.

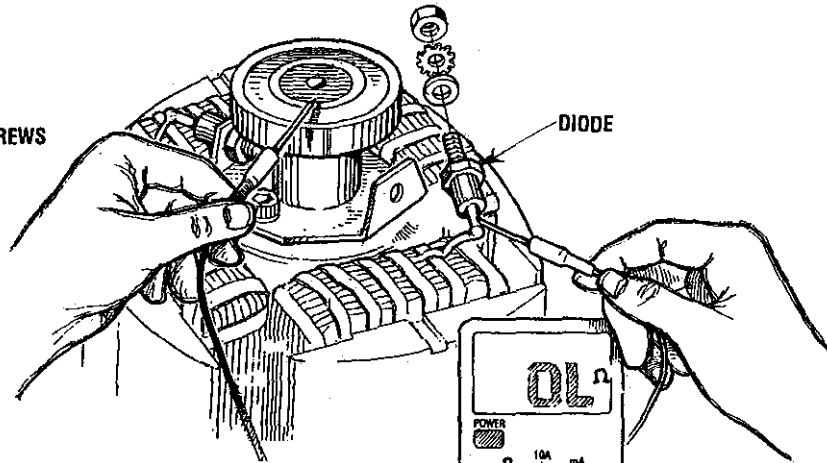
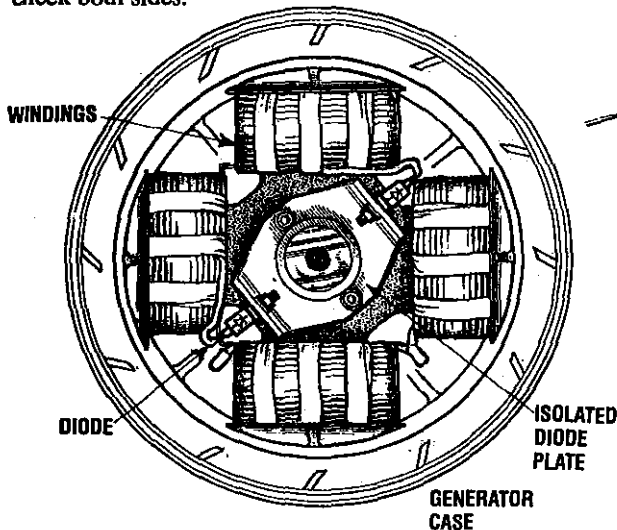

## TESTING FOR A WINDING SHORTED TO GROUND

## CONTINUITY TEST

With the diode still removed from the isolated plate, test the continuity between the winding/diode connection and the generator case.

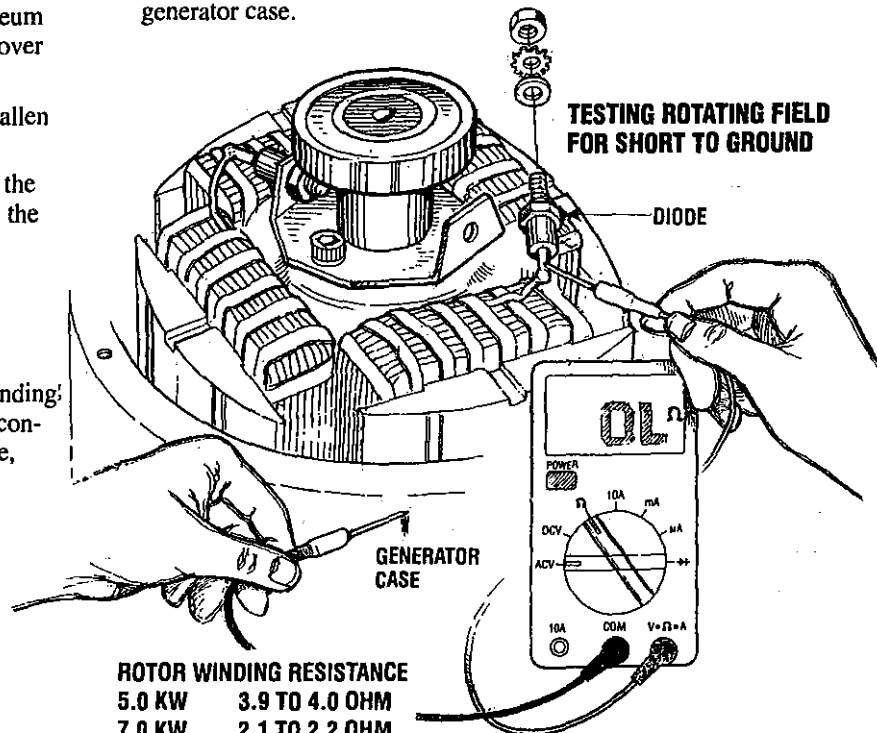

ROTOR WINDING RESISTANCE	
5.0 KW	3.9 TO 4.0 OHM
7.0 KW	2.1 TO 2.2 OHM

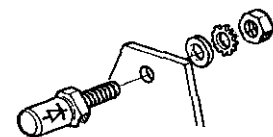
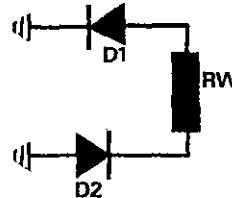

## TESTING THE DIODES

Refer to the following pages.



# TESTING THE DIODES/CONTROL PANEL

## TESTING THE DIODES - ALL MODELS

Carefully unsolder the winding connection to the diode and remove the diode using a thin walled, deep well 7/16" (11mm) socket and a box wrench as needed.

Test the diode as shown with ohmmeter leads at both ends, then reverse the positions.

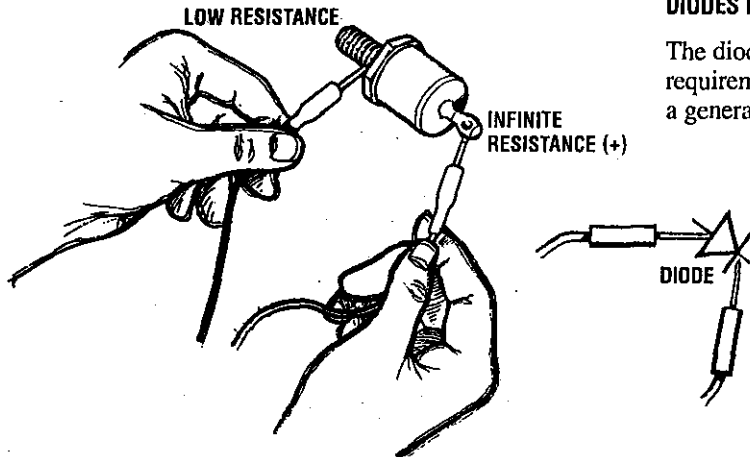

A low resistance should be found with the leads in one direction and infinite resistance (blocking) in the other direction.

**DIODES: 1.4 - 1.5 OHMS (APPROX.) USING A 260 FLUKE 76 METER.**

**NOTE:** Different meter models may show different ohm values, but should read the same for both diodes.

**DIODES RATING 1600 VOLTS 26 AMPS**

The diode's rating is far in excess of the circuit's requirements. Most likely a diode failure will result from a generator overspeed or load surge.

## CONTROL BOX / CONTROL PANEL COMPONENTS

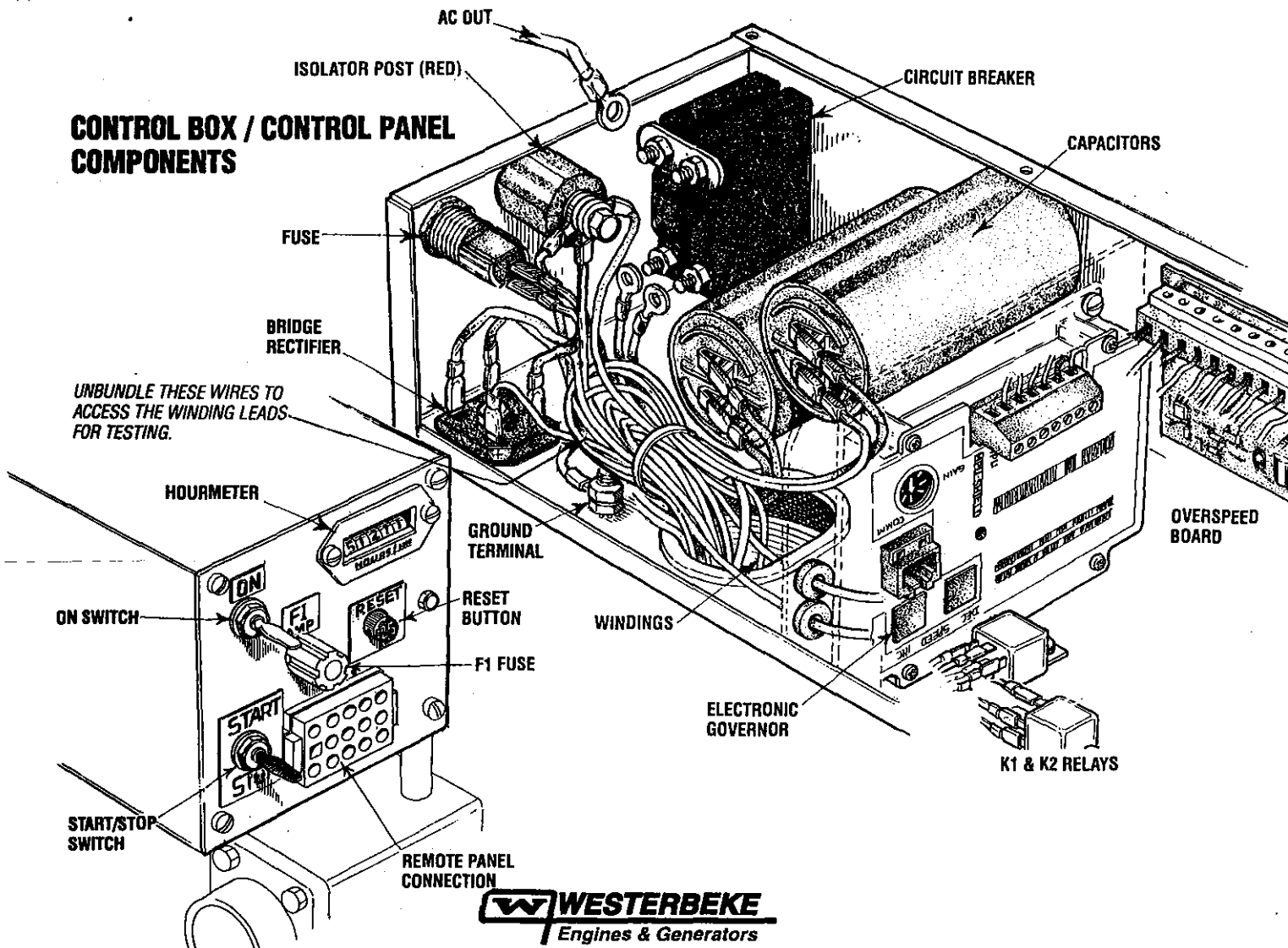

# BC GENERATORS TROUBLESHOOTING

## NO AC VOLTAGE OUTPUT

### EXCITING THE GENERATOR

To quickly determine a short or an open in the main stator winding, excite the generator with 12 VDC using one exciter winding group to accomplish this.

The AC voltage that the generator will produce measured between the line and neutral during excitation will be very low.

**NORMAL AC VOLTAGE DURING 12 VDC EXCITATION:**

**12 - 16 VOLTS AC**

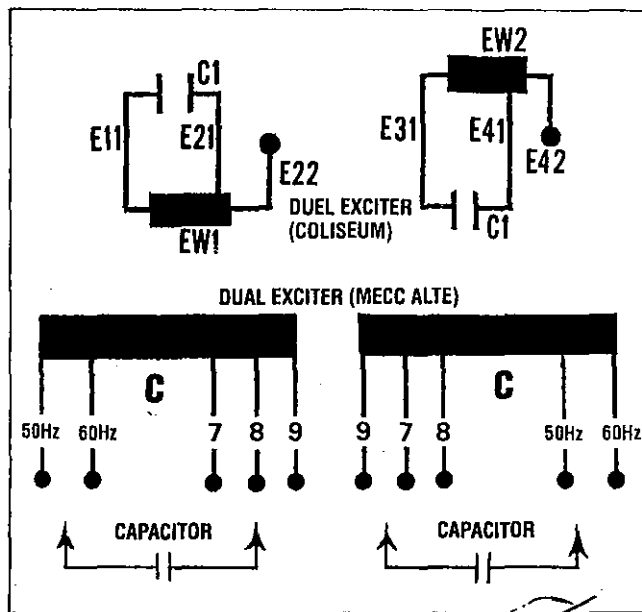
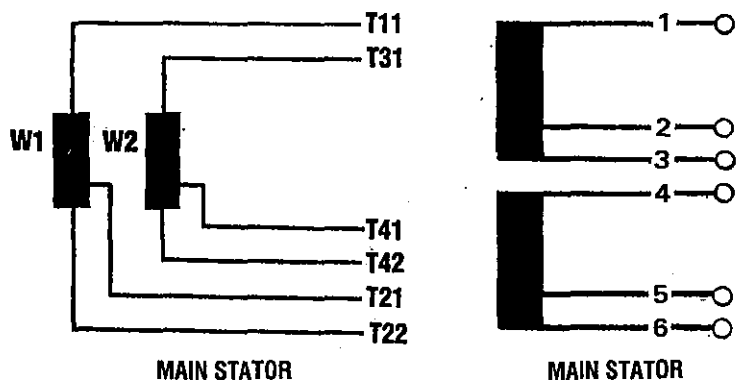

### EXCITING PROCEDURE

Locate one of the exciter winding groups in the generator. Unplug all connections from both capacitors. Connect 12 VDC across the winding using the winding end connection.

For example: Winding group EW1 between connection E11 and E22. Winding group C between #50Hz and #9.

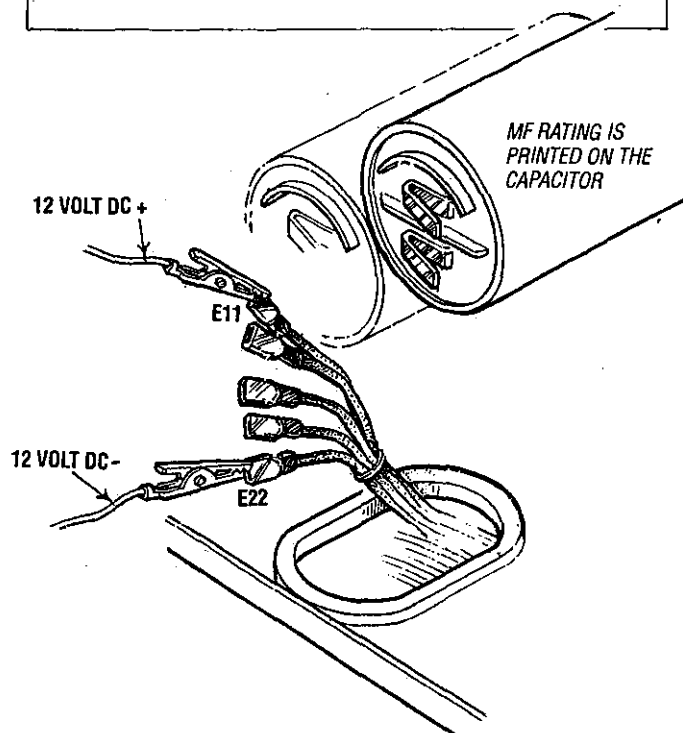

# BC GENERATORS TROUBLESHOOTING

## REACTION DURING EXCITATION (Unit running-12VDC applied to winding)

1. A very low AC outout and loading of the drive engine and a growling noise from the generator end.  
This indicates a shorted stator winding to ground or the stator windings are shorted to each other. Isolate the winding groups and verify a short to ground. No continuity should be found between the two isolated stator winding groups.
2. No reaction from the generator or drive engine. No AC output.  
This is an indication of an open in one of the main stator winding groups. Isolate the winding groups and verify an open winding.

### No Continuity between Isolated Stator Windings and Ground

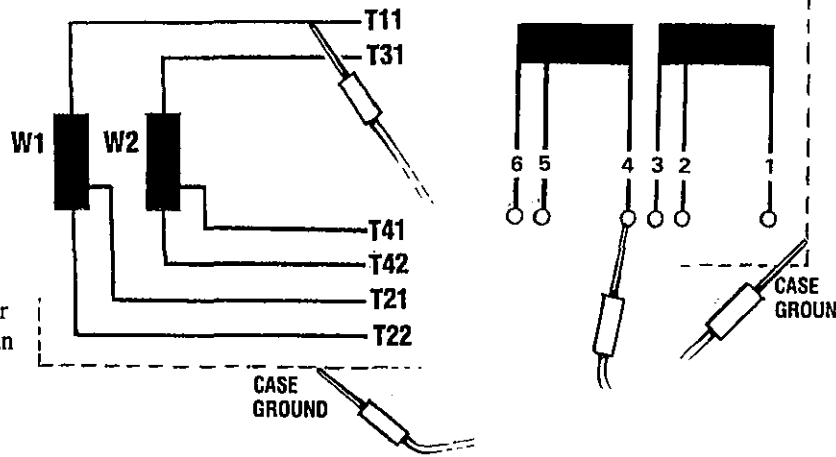

### No Continuity between Isolated Stator Winding Groups

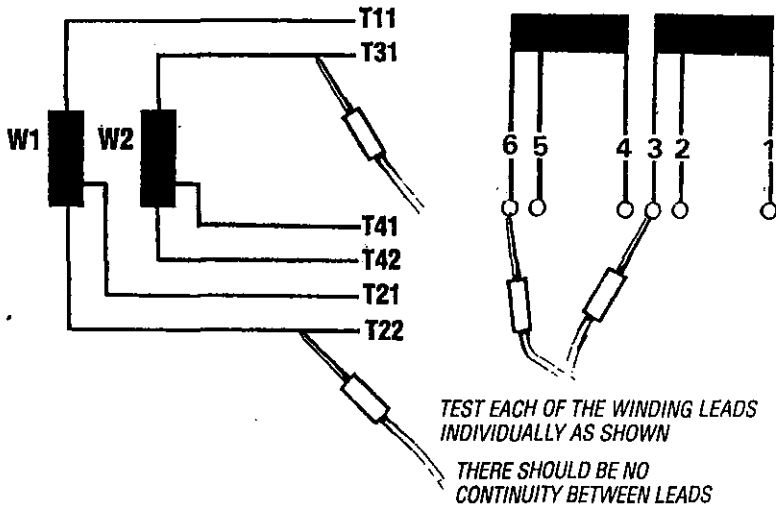

TEST EACH WINDING TO CASE GROUND

# BC GENERATORS TROUBLESHOOTING

## TESTING THE EXCITER WINDINGS

AC voltage can be measured across the capacitor electrical connections while the generator is operating. This voltage may be as high as 350 to 400 volts AC.

This AC voltage build-up is accomplished as the exciter winding for each capacitor charges the capacitor and the capacitor discharges back into the winding. This flow of saturating AC in the exciter winding produces a phase-imbalance type of field that affects the auxiliary windings of the rotor.

The AC voltage reading is taken between the two electrical connections on each separate capacitor with the generator operating at its correct no load speed.

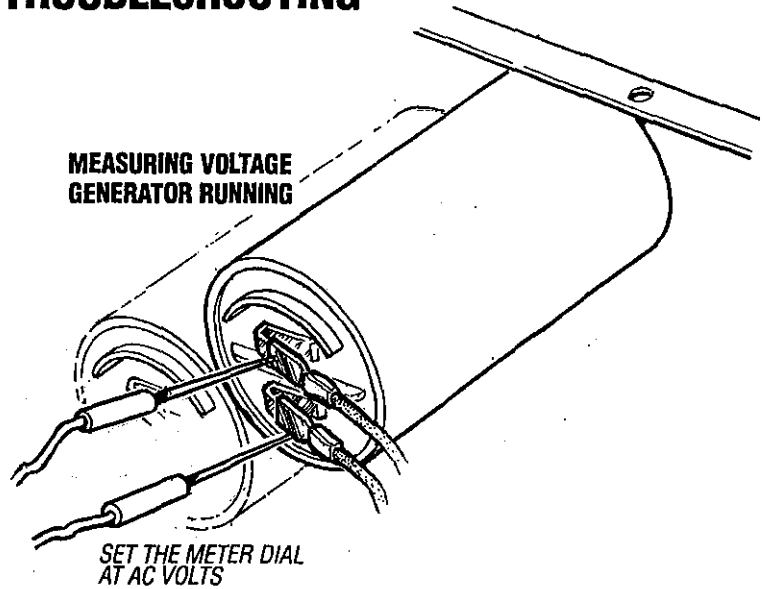

## EXCITER WINDING INTEGRITY (RESIDUAL AC VOLTAGE)

The condition of each exciter winding can be determined by the residual AC voltage each exciter winding should be producing with the generator running at proper no load speed.

To do this: Unplug all connections from the capacitor. Locate the electrical connection for each winding end. Place your AC volt meter connects across these two connections. Start the generator and observe the residual AC voltage produced by the winding. Check the other exciter winding in the same way. Residual AC voltage lower than listed below will indicate a faulty winding.

### RESIDUAL AC VOLTAGES (Each exciter winding)

5.0 KW	E11 - E22 AND E31 - E42	5 - 6 VAC
	#50 - #9 AND #50 - #9	7 - 9 VAC
7.0 KW	E11 - E22 AND E31 - E42	5 - 6 VAC
	#50 - #9 AND #50 - #9	7 - 9 VAC

THERE SHOULD BE NO CONTINUITY BETWEEN LEADS 50HZ AND #9 TO CASE GROUNDS

MEASURE THE RESISTANCE VALUE OF THE EXCITER WINDINGS BETWEEN THE END LEADS OF EACH WINDING

TESTING WINDING LEADS FOR NO CONTINUITY TO METAL CASE

CASE GROUND

### MECCALTE MODEL

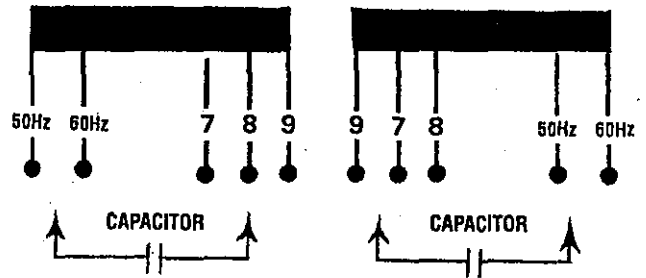

### COLISEUM MODEL

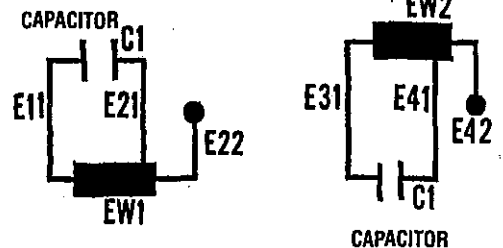

MAIN STATOR WINDING RESISTANCE LESS THAN ONE OHM FOR EACH WINDING GROUP

MAIN STATOR RESIDUAL VOLTAGE LINE TO NEUTRAL 4-6 AC VOLTS (THIS INDICATES GOOD STATOR WINDINGS)

# BC GENERATORS TROUBLESHOOTING

## TESTING CONTINUITY

Quick field check (no capacitance scale on meter).

Connect a digital ohm meter or analog ohm meter (high scale) to the capacitor terminals. The meter will register an arbitrary ohm value for the material in the capacitor. The meter's battery will then start to charge the capacitor and the ohm value will increase.

If the meter does not react as above, the capacitor is faulty.

The method above indicates a presumably good capacitor, but does not verify its microfarad rating as would be necessary when troubleshooting a capacitor whose MF rating has dropped causing a low AC voltage output. In such cases, the capacitor's rating *MUST* be verified accurately.

## TESTING THE CAPACITOR(S)

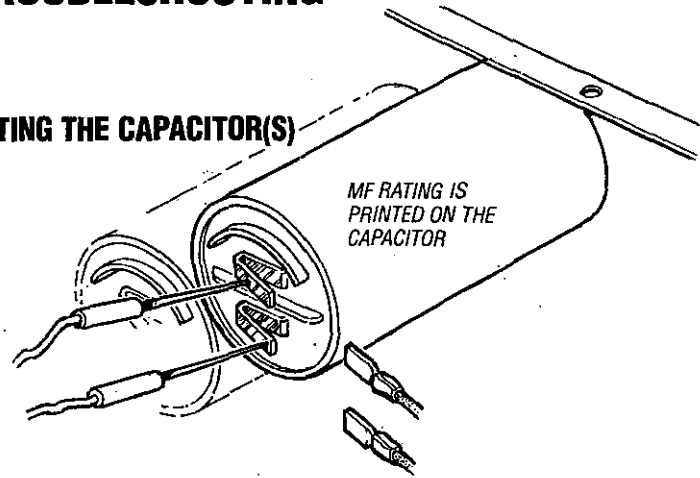

**⚠ WARNING:** *Capacitors must be discharged before handling as they store electricity and can pack a potentially lethal charge even when disconnected from their power source.*

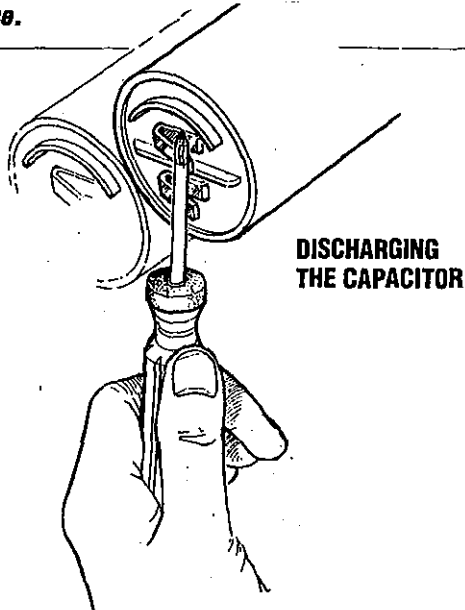

## CAPACITOR RATINGS AND PART NUMBERS

25MFD	Pn#046875
35MFD	Pn#049627
55MFD	Pn#048816
60MFD	Pn#048018

# BC GENERATOR COMPONENTS

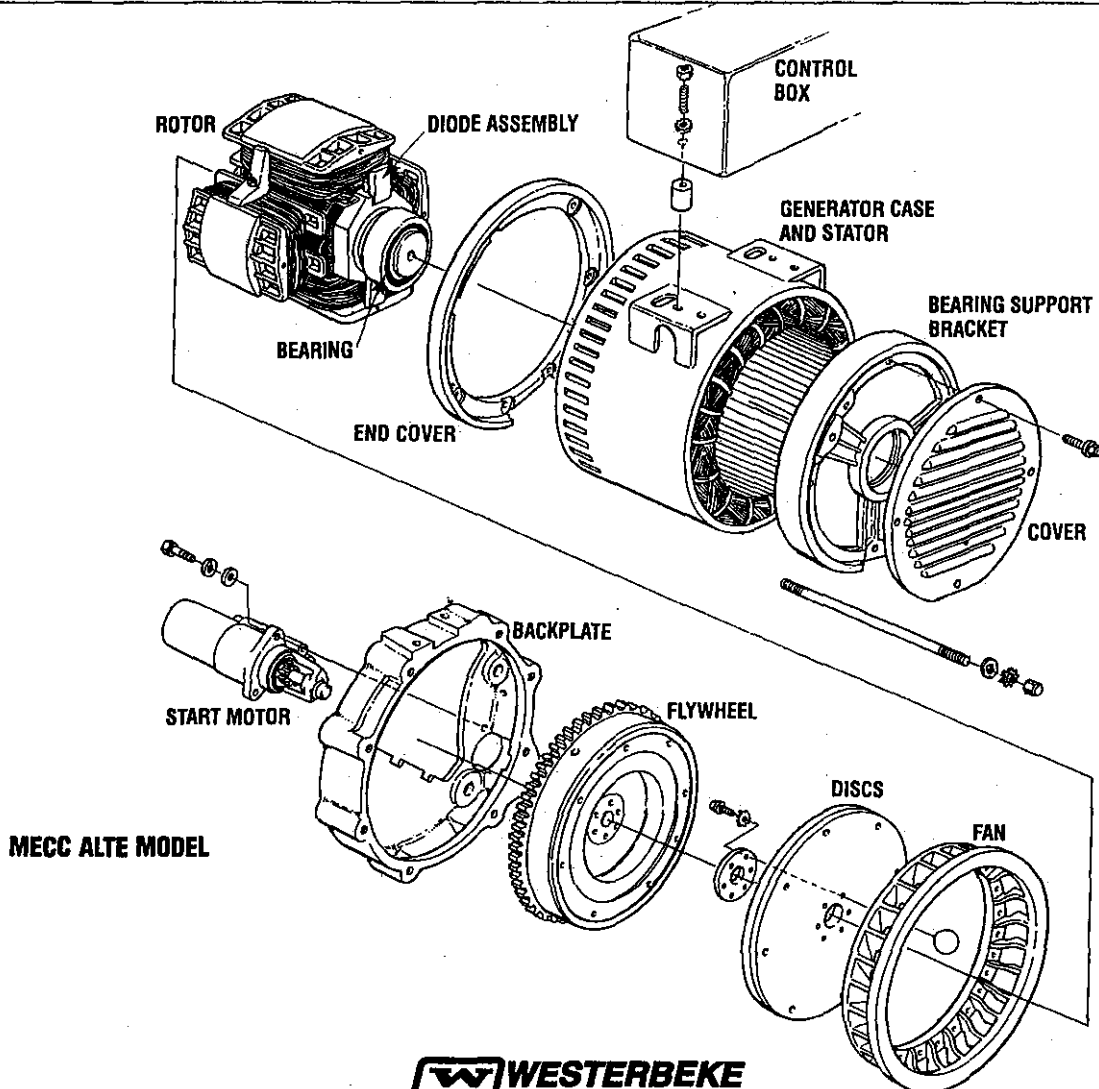
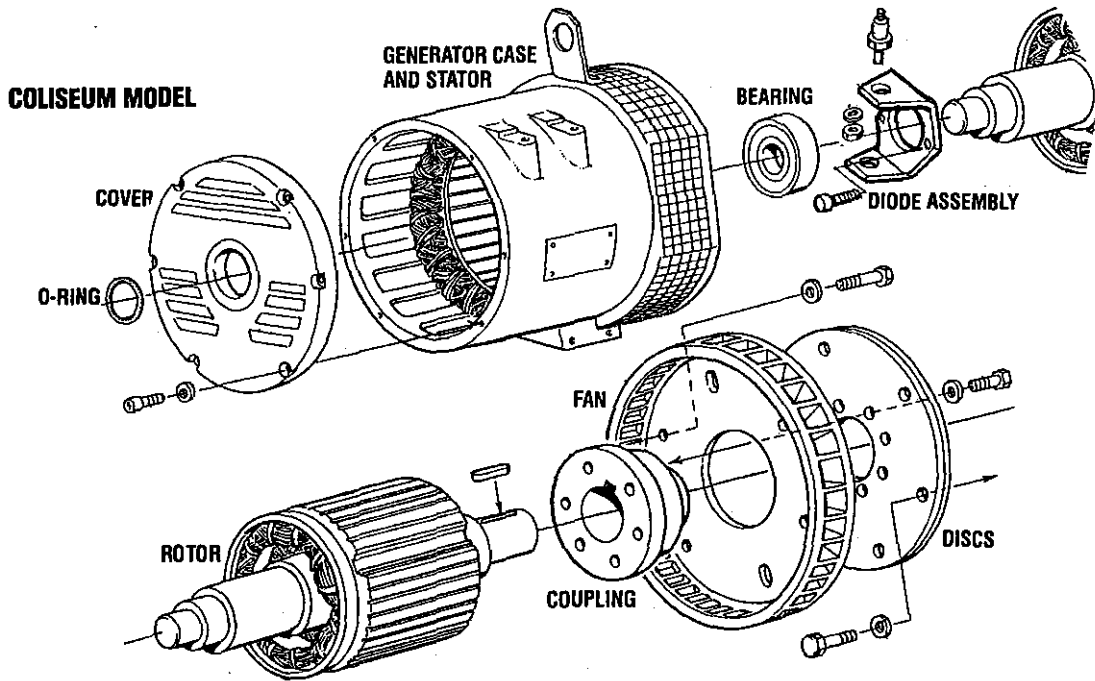

# GENERATOR WIRING DIAGRAM #46876

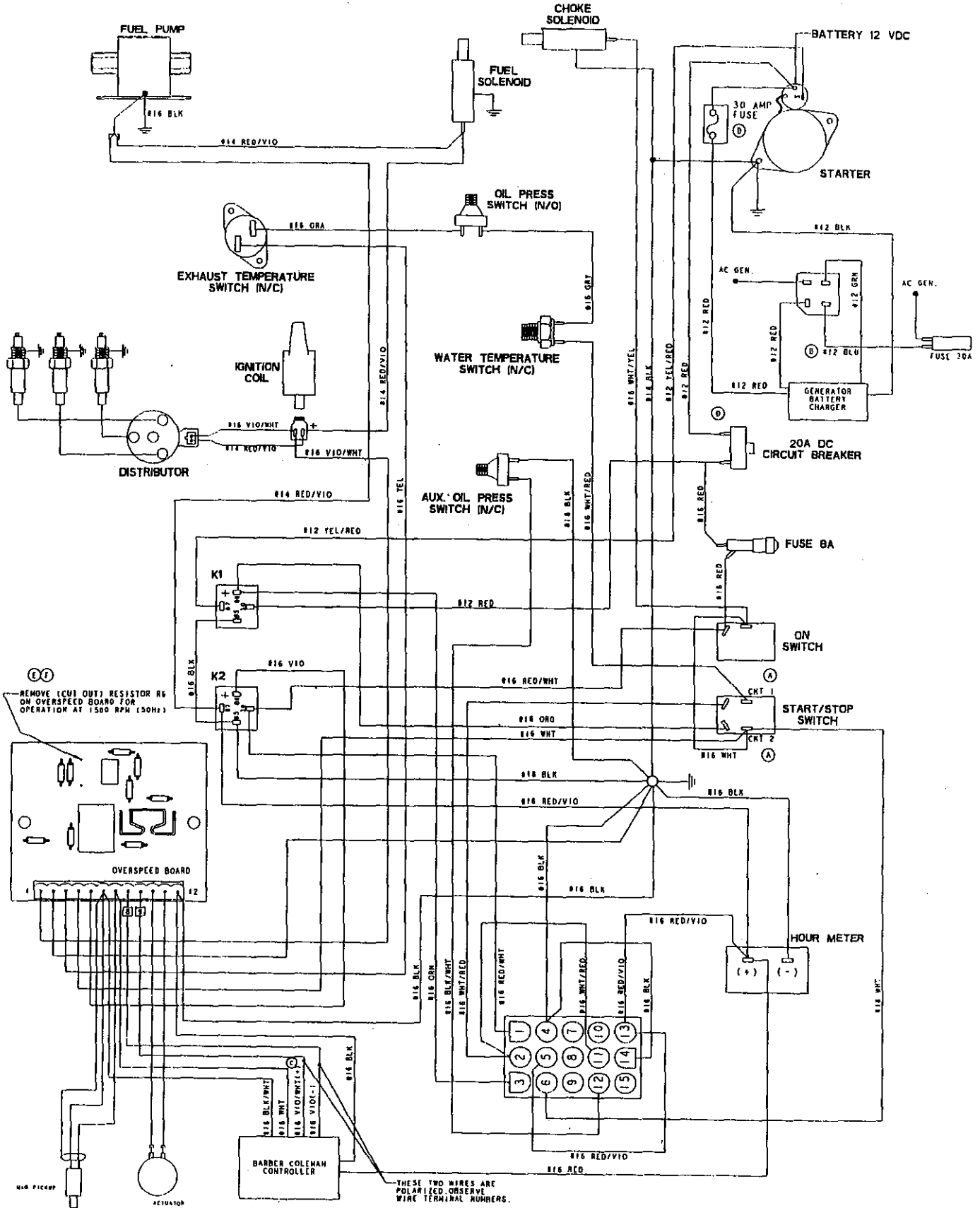

REMOVE (CUT OUT) RESISTOR R6 ON OVERSPEED BOARD FOR OPERATION AT 1500 RPM (150Hz)

THESE TWO WIRES ARE POLARIZED. OBSERVE WIRE TERMINAL NUMBERS.  
 OR CHECK WIRE WITH VOM  
 1. ATTACH RED LEAD OF VOM TO RED WIRE FROM CONTROLLER.  
 2. ATTACH BLACK LEAD OF VOM TO EACH PURPLE WIRE INDIVIDUALLY. OBSERVE POLARITY.

