

NOTES:  
 1. FIRE SUPPRESSION SYSTEM CONNECTION IS NOT A POWER SOURCE. THIS CIRCUIT MUST BE CLOSED TO RUN. AN OPEN CIRCUIT WILL STOP THE GENSET.  
 REMOVE JUMPER FOR FIRE SUPPRESSION SYSTEM CONNECTION (SEE NOTE 1)

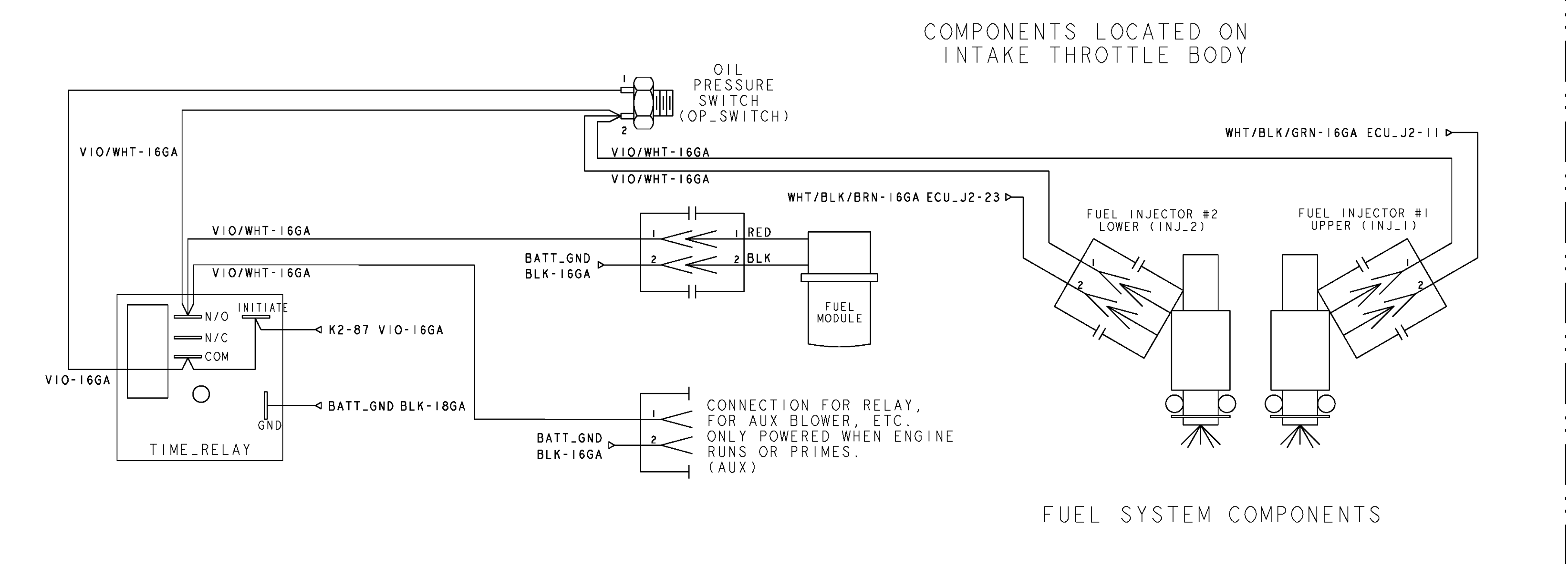
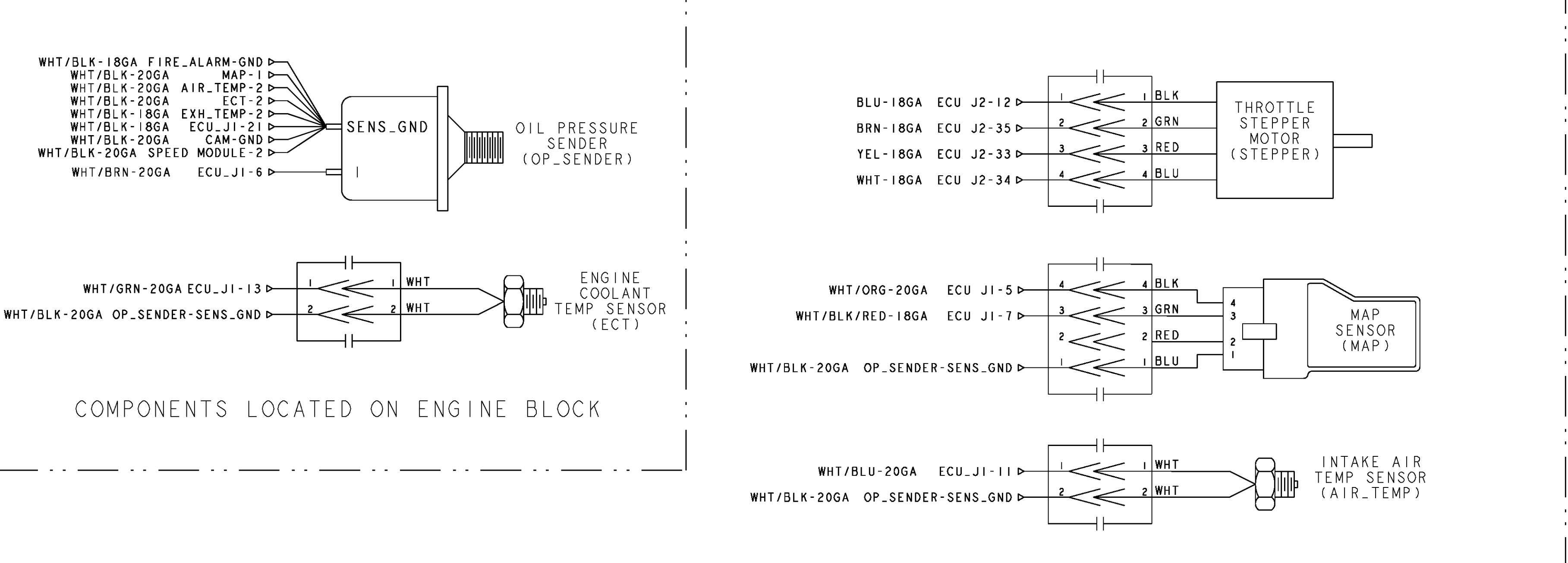
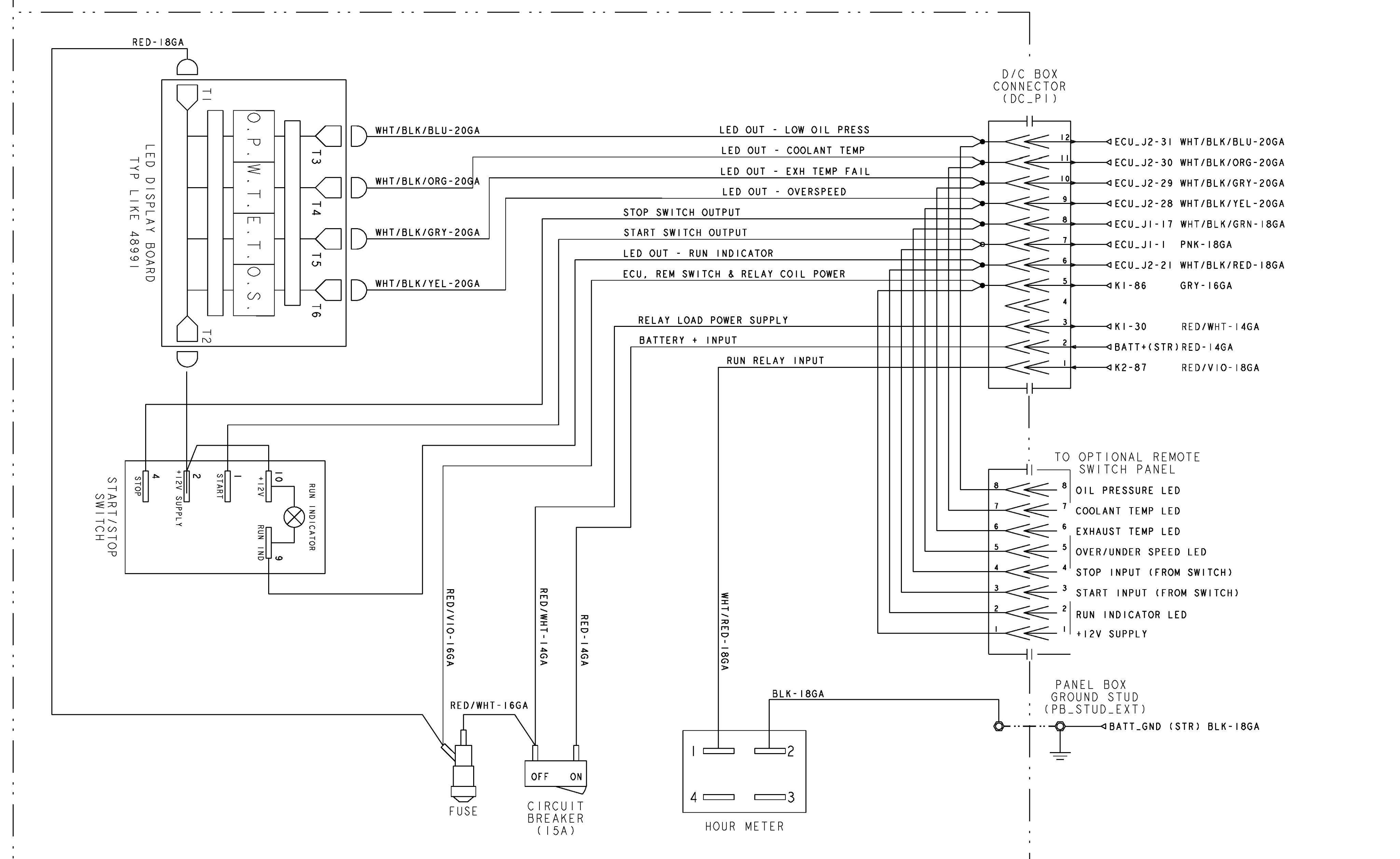
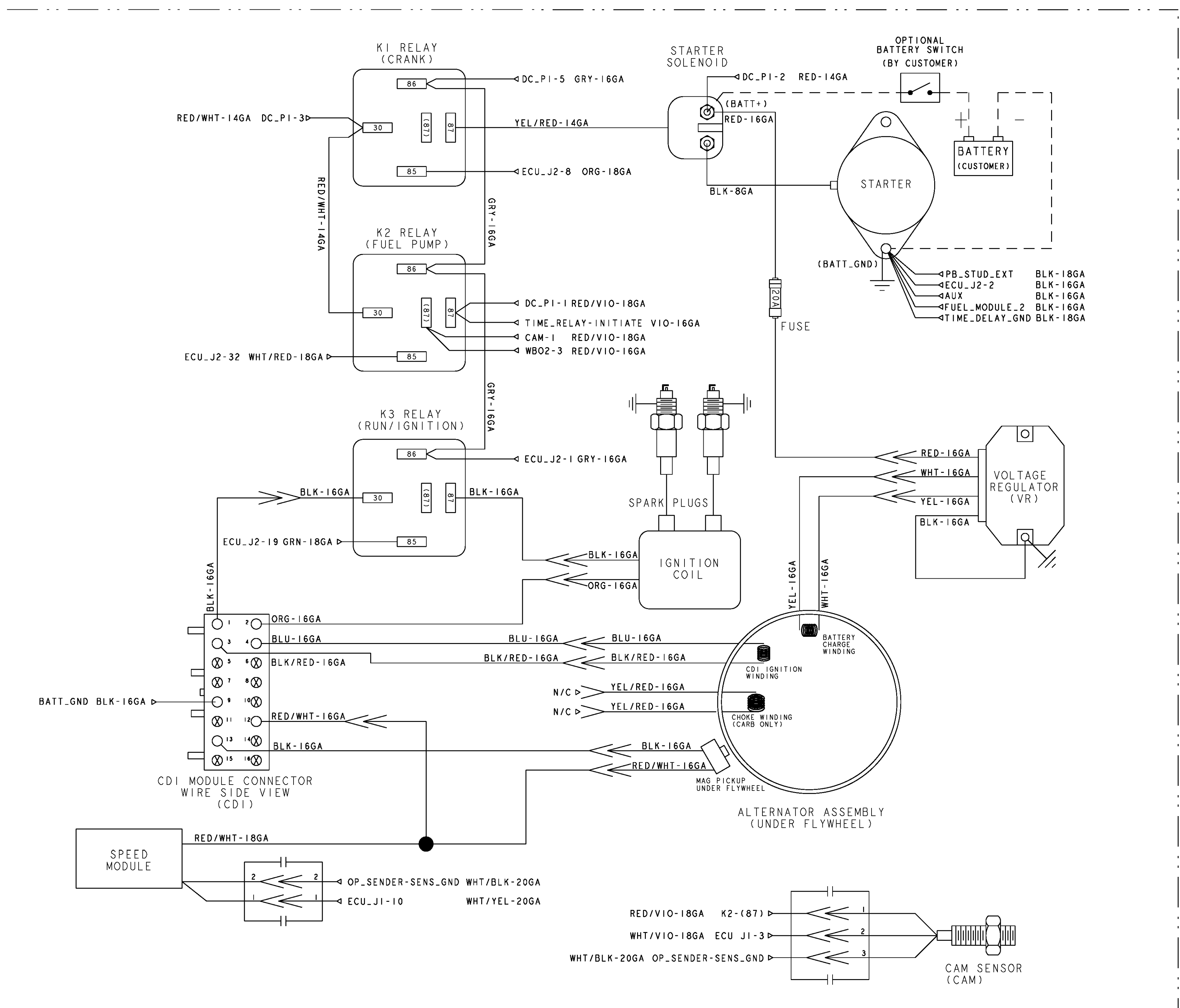

| ECO NO. | DATE      | REV. | REVISION RECORD   | AUTH. | DR. BY |
|---------|-----------|------|---|-------|--------|
| 6703    | 8-17-2010 | A    | REMOVED SPEED MODULE; ADDED CRANK SENSOR                                | GA    |        |
| 6823    | 9-9-2011  | B    | REMOVED CRANK SENSOR; ADDED SPEED MODULE; RENAMED MODEL NAME TO 3.5 SCG | GA    |        |

| TOLERANCES (UNLESS OTHERWISE NOTED) |             | WESTERBEKE CORPORATION<br>TAUNTON, MA. 02780 |                |
|-------------------------------------|-------------|--|----------------|
| INCHES                              | MILLIMETERS | TITLE  |                |
| .XX ± .02                           | X ± 1.0     | WIRING DIAGRAM 3.5 SCG                       |                |
| .XXX ± .005                         | XX ± .13    | MULTI-PORT                                   |                |
| CAST ± .03                          |             | DRAWN BY                                     | DATE           |
| FINISH ± .01                        |             | GMA  | 30/Mar/110     |
|                                     |             | APPROVED BY                                  | DATE           |
|                                     |             |  |                |
| DIMENSIONS                          | SCALE NONE  | SIZE   | DRAWING NUMBER |
| INCHES                              |             |  |                |
| MILLIMETERS                         |             |  |                |
| (WHEN APPLICABLE)                   |             | SHT. 1 OF 1                                  | <b>E 54609</b> |