

NOTES:  
 1. FIRE SUPPRESSION SYSTEM CONNECTION IS NOT A POWER SOURCE. THIS CIRCUIT MUST BE CLOSED TO RUN. AN OPEN CIRCUIT WILL STOP THE GENSET.

REMOVE JUMPER FOR FIRE SUPPRESSION SYSTEM CONNECTION (SEE NOTE 1)

- ECU J1-2 WHT/GRY-18GA
- OP\_SENDER-SENS\_GND WHT/BLK-18GA

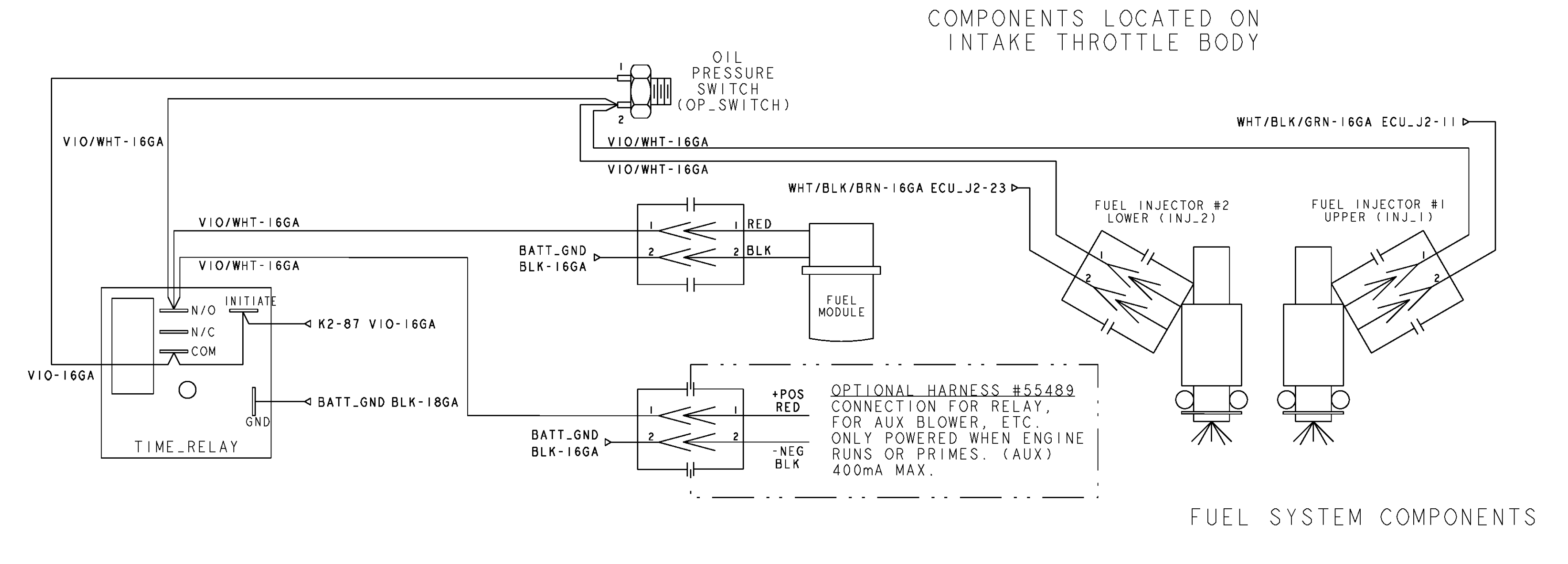
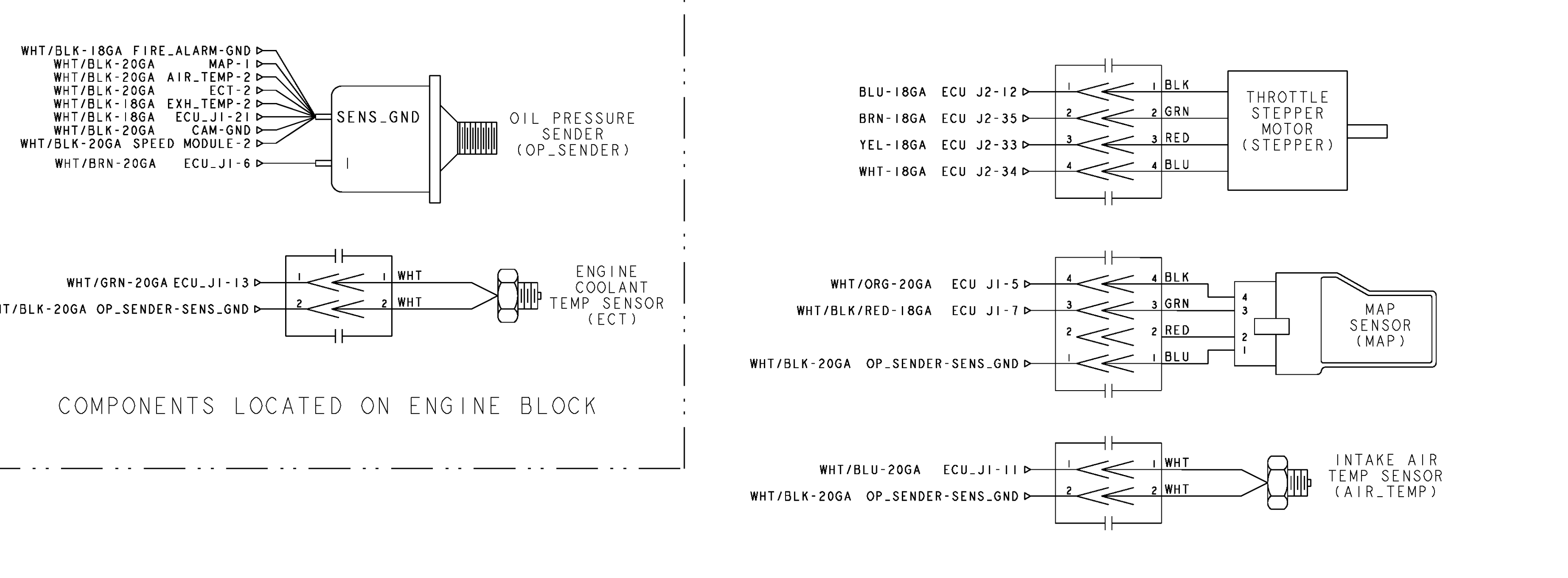
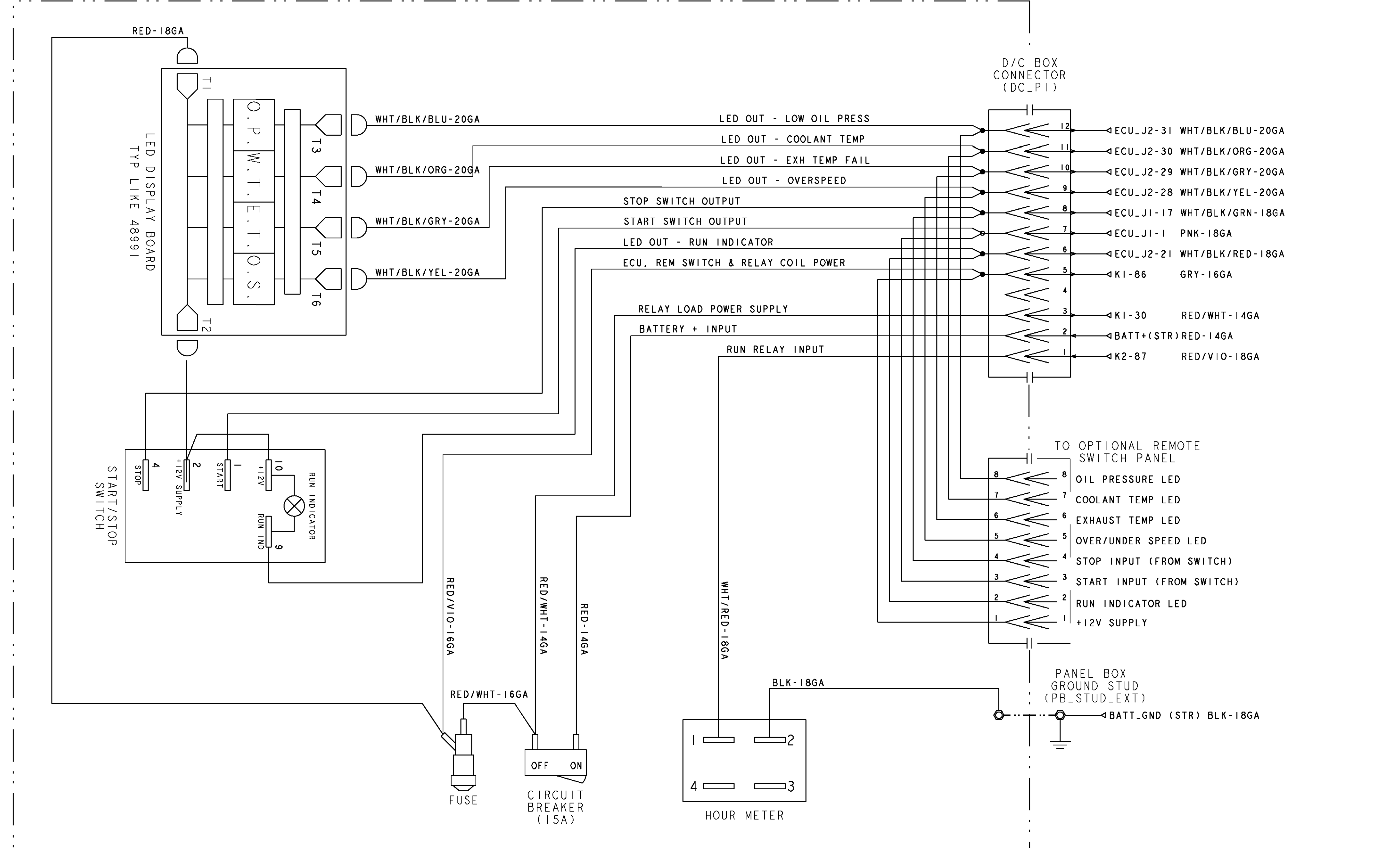
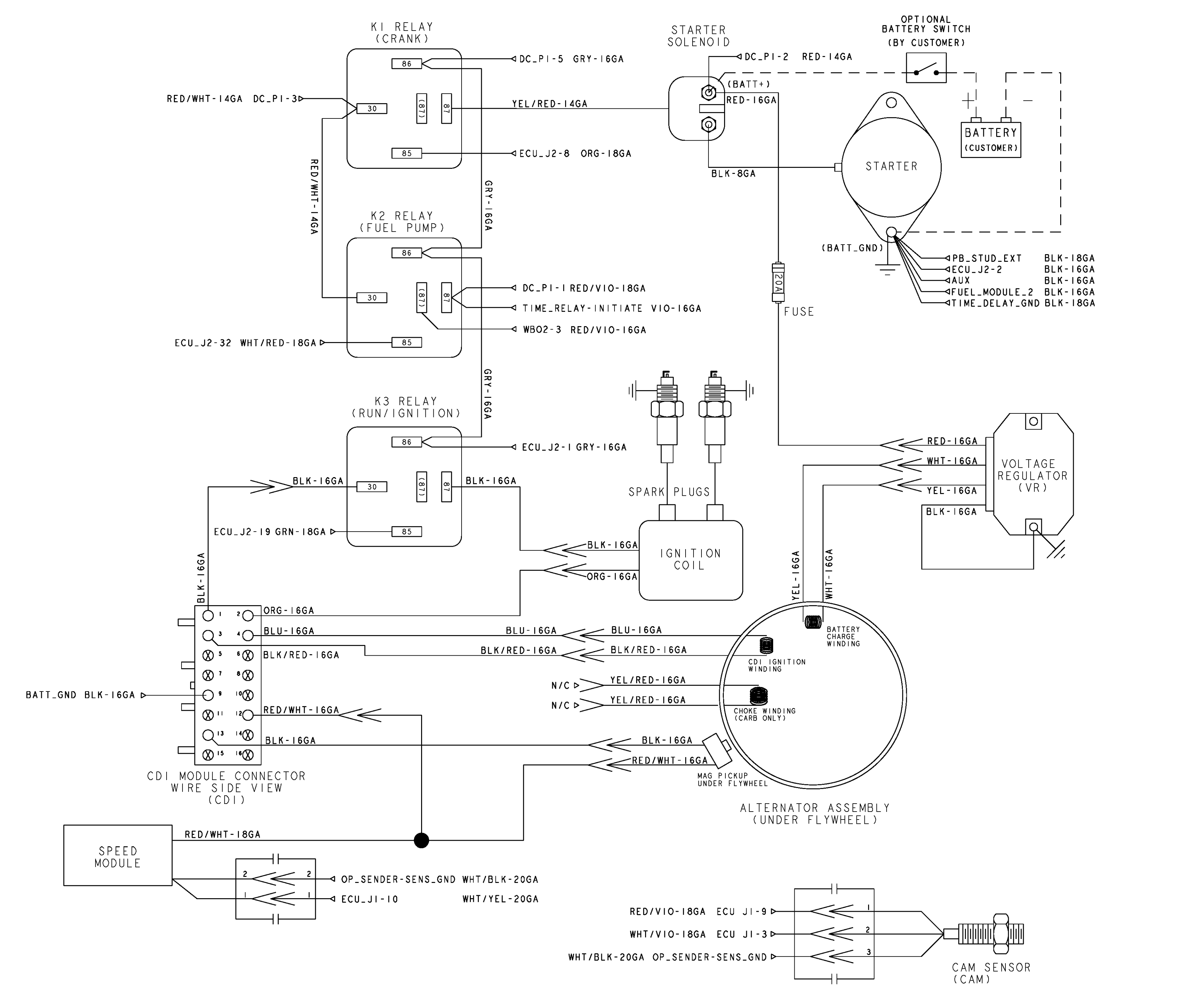

ECO NO.	DATE	REV.	REVISION RECORD	AUTH.	DR. BY
6703	8-17-2010	A	REMOVED SPEED MODULE; ADDED CRANK SENSOR		GA
6823	8-19-2011	B	REMOVED CRANK SENSOR, ADDED SPEED MODULE RENAMED MODEL NAME TO 3.5 SCG		GA
6831	10-26-2011	C	CAM-1 WAS CONNECTED TO K2 PIN (87), NOW IS ECU J1 PIN 9		GA
6902	8-14-2012	D	ADD NOTE "OPTION HARNESS #55489"		GA

TOLERANCES (UNLESS OTHERWISE NOTED)		WESTERBEKE CORPORATION TAUNTON, MA. 02780	
INCHES	MILLIMETERS	TITLE	
.XX ± .02	X ± 1.0	WIRING DIAGRAM 3.5 SCG	
.XXX ± .005	XX ± .13	MULTI-PORT	
CAST ± .03			
FINISH ± .01			
DIMENSIONS		APPROVED BY	DATE
INCHES		GMA	30/Mar/10
MILLIMETERS		SCALE NONE	SIZE
(WHEN APPLICABLE)		DRW. NUMBER	REV.
		SHT. 1 OF 1	<b>E 54609</b>