

ECO NO.	DATE	REV.	REVISION RECORD	AUTH.	DR. BY
5580	7/78	A	UPDATE WIRE COLORS AND REDRAWN	JCA	
5941	3/85	B	REMOVED BALLAST RESISTOR.		GA

SCHEMATIC DIAGRAM

RESPONSIBILITY FOR SAFETY REGULATIONS

1. THE WESTERBEKE 70GA GASOLINE MARINE PROPULSION ENGINE AS SHIPPED FROM THE FACTORY AND EXCLUSIVE OF ITS INSTRUMENT PANEL COMPLIES WITH U.S. COAST GUARD REGULATION 33 CFR-183. THE STANDARD INSTRUMENT PANEL DOES NOT NECESSARILY SO COMPLY AND IS INTENDED TO BE INSTALLED ABOVE DECK AND ISOLATED FROM GASOLINE SOURCES IN ACCORDANCE WITH 33CFR 183.410 (b).
2. IT IS THE RESPONSIBILITY OF THE BOAT MANUFACTURER TO INSURE THAT THE INSTALLATION OF THIS ENGINE AND ITS INSTRUMENT PANEL COMPLY WITH 33CFR-183.
3. AN ON-OFF SWITCH MUST BE INSTALLED IN THIS LINE TO DISCONNECT THE STARTER CIRCUIT FROM THE BATTERY IN AN EMERGENCY AND WHEN LEAVING THE BOAT. TWELVE VOLT STARTERS TYPICALLY DRAW 200 TO 300 AMPS WHEN CRANKING. THE DURATION OF INDIVIDUAL CRANKING CYCLES SHOULD NOT EXCEED 30 SECONDS. A SWITCH WITH A CONTINUOUS RATING OF 175 AMPS AT 12 VOLTS WILL NORMALLY SERVE THESE FUNCTIONS BUT SUCH A SWITCH MUST NEVER BE USED TO "MAKE" THE STARTER CIRCUIT.
4. THIS PRODUCT IS PROTECTED BY A MANUAL RESET CIRCUIT BREAKER LOCATED NEAR THE STARTER AND AS CLOSE TO THE SOURCE OF CURRENT AS POSSIBLE. EXCESSIVE CURRENT DRAIN ANYWHERE IN THE INSTRUMENT PANEL, WIRING OR ENGINE WILL CAUSE THE BREAKER TO TRIP. IN THIS EVENT MOST ENGINE MODELS WILL SHUT DOWN BECAUSE THE OPENED BREAKER DISCONNECTS THEIR FUEL SUPPLY. THEREFORE THE BUILDER OWNER MUST BE SURE THAT THE INSTRUMENT PANEL WIRING AND ENGINE ARE INSTALLED TO PREVENT CONTACT BETWEEN ELECTRICAL DEVICES AND SALT WATER.

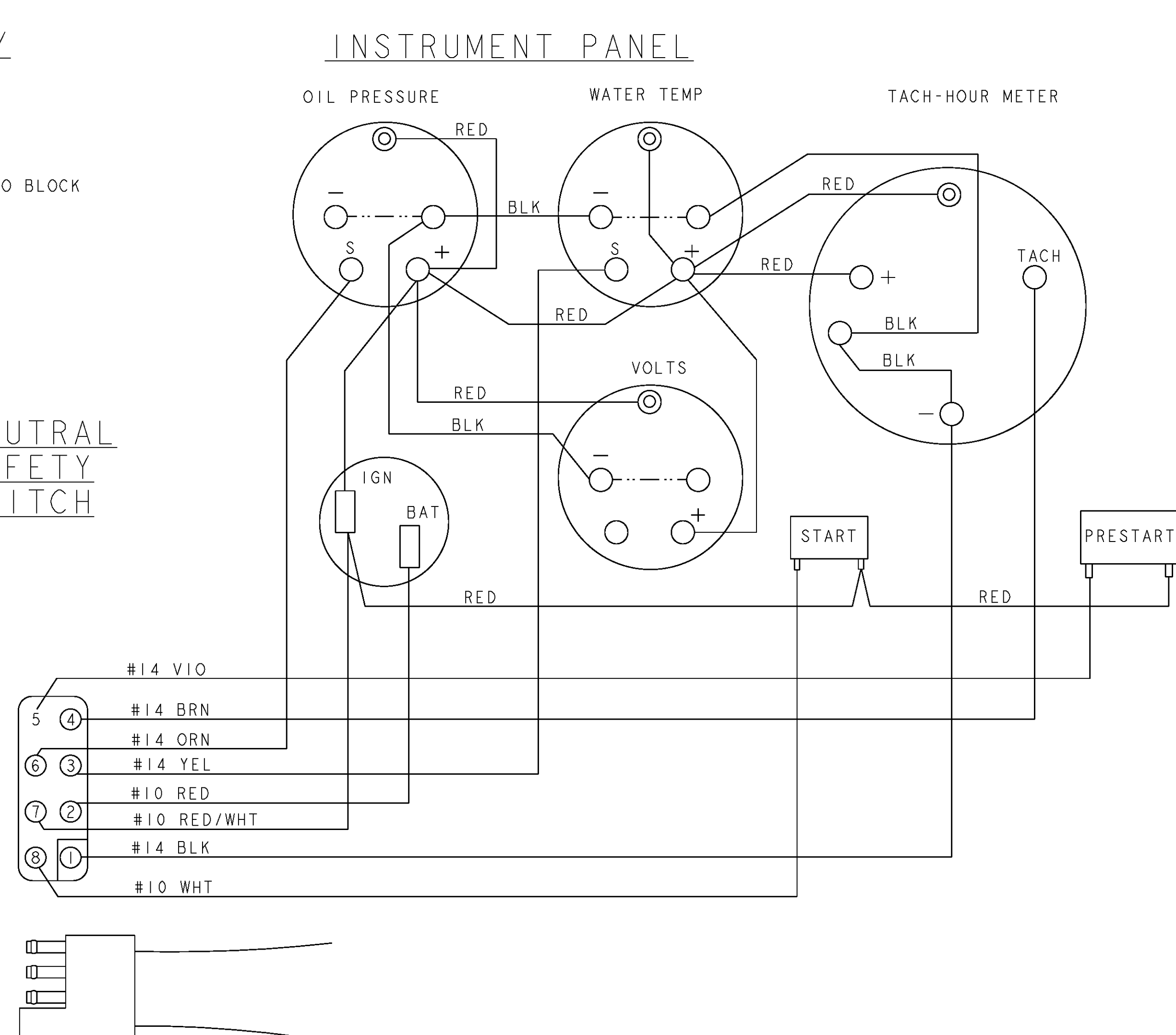
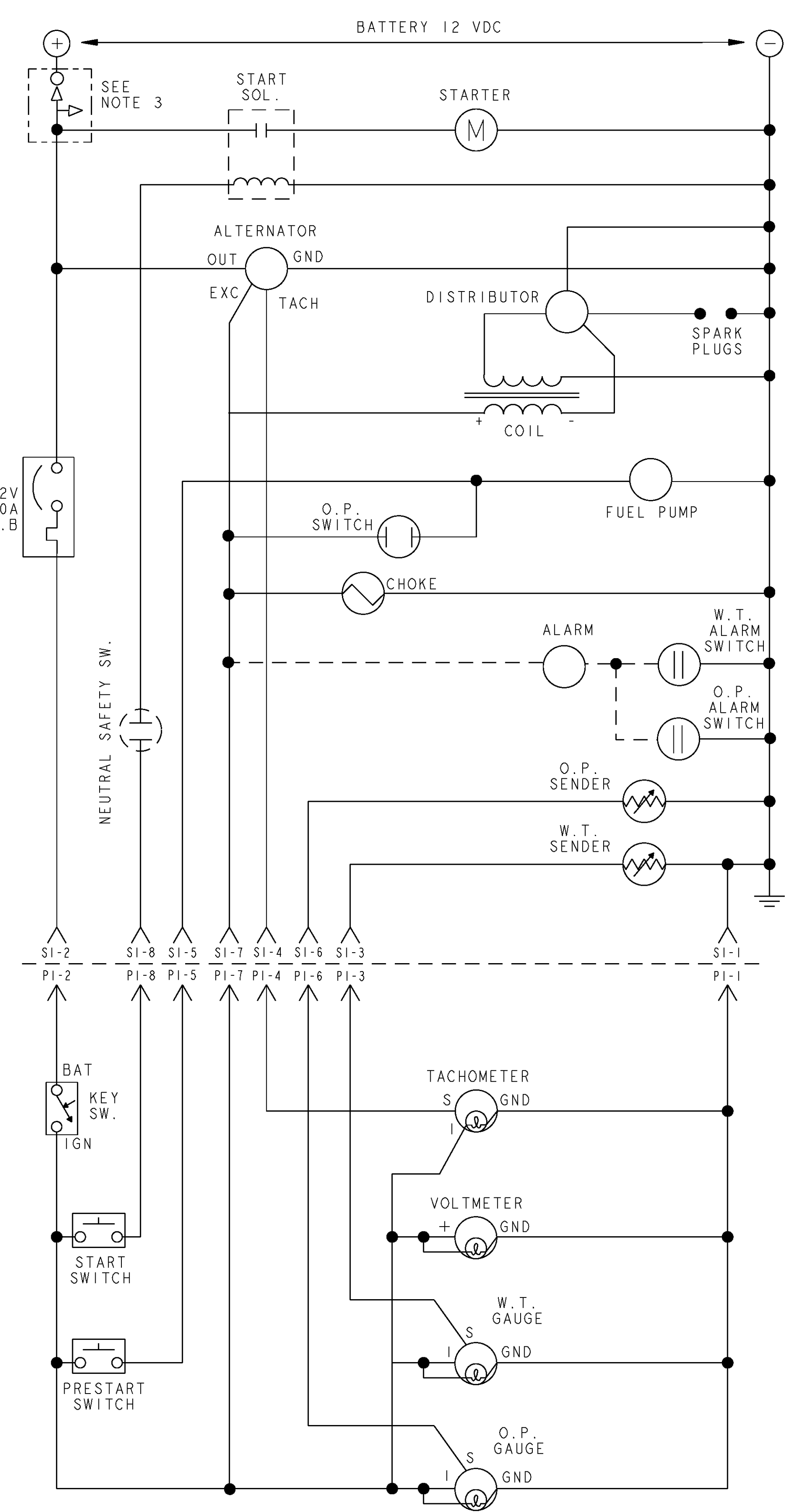
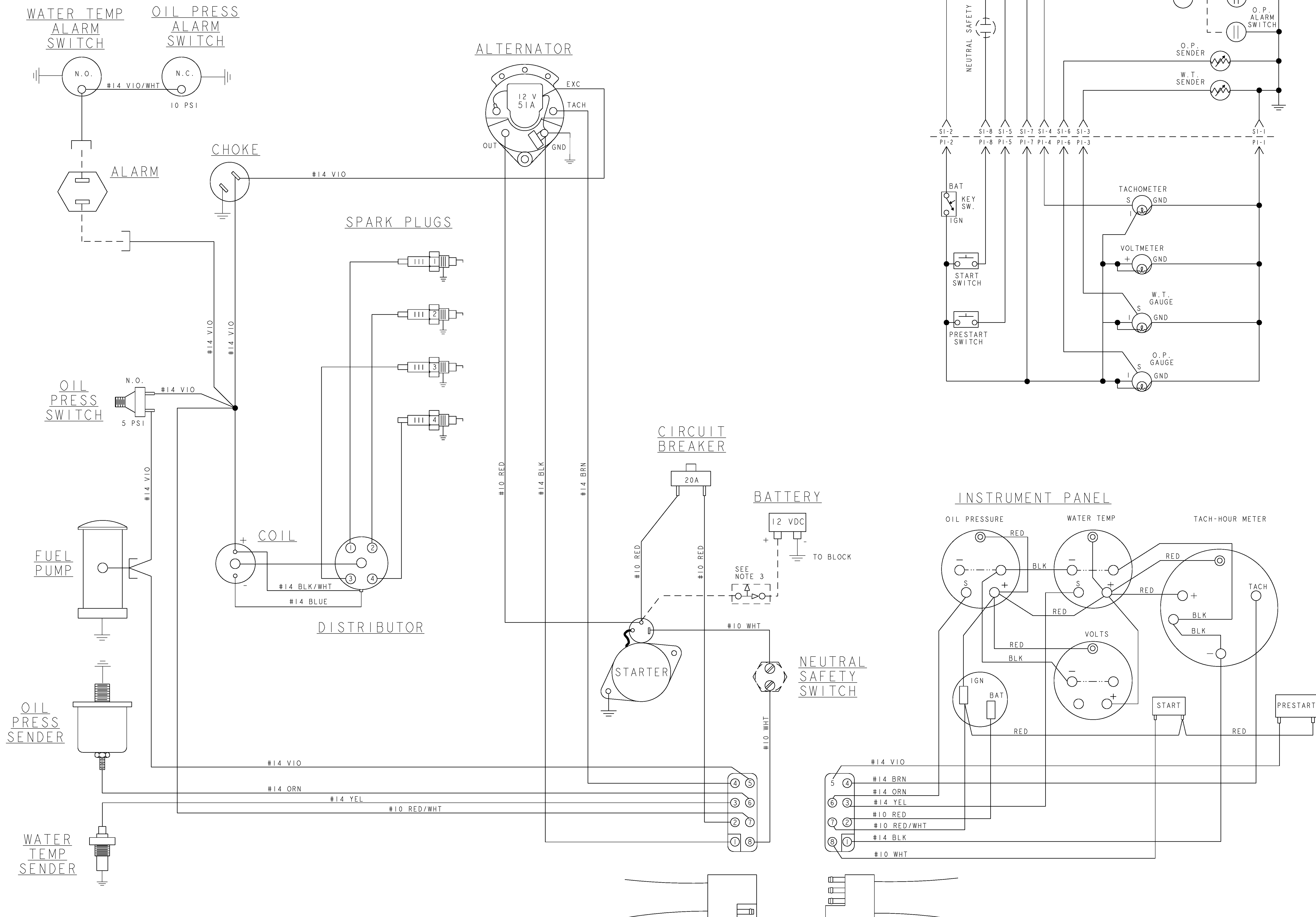

TOLERANCES (UNLESS OTHERWISE NOTED)		WESTERBEKE CORPORATION TAUNTON, MA. 02780	
INCHES	MILLIMETERS	TITLE	
.XX ± .02	.XX ± .5	WIRING DIAGRAM W70GA	
.XX ± .005	.XX ± .13	GASOLINE PROPULSION ENGINE	
ANGLES		DRAWN BY	GA
FINISH		DATE	02/Jul/03
DIMENSIONS		APPROVED BY	
INCHES		SCALE	NONE
(WHEN APPLICABLE)		SIZE	DRAWING NUMBER
		SHT. 1 OF 1	E 48630
		REV.	B